

ENGINE

6G72

CONTENTS

BRACKET	122	INTAKE MANIFOLD PLENUM AND THROTTLE BODY	32
CAMSHAFT, ROCKER ARMS AND BEARING CAPS	87	OIL PAN AND OIL PUMP	102
CRANKSHAFT, FLYWHEEL AND DRIVE PLATE	115	PISTON AND CONNECTING ROD	108
CYLINDER HEAD AND VALVES – SOHC	91	ROCKER ARMS AND CAMSHAFTS	77
CYLINDER HEAD AND VALVES – DOHC	98	SEALANT	23
EXHAUST MANIFOLD	67	SERVICE SPECIFICATIONS	14
GENERAL INFORMATION	2	SPECIAL TOOLS	24
GENERAL SPECIFICATIONS	12	THROTTLE BODY.....*	37
GENERATOR AND DRIVE BELT	27	TIMING BELT – SOHC	48
IGNITION SYSTEM	44	TIMING BELT- DOHC	54
INTAKE MANIFOLD AND FUEL PARTS	62	TORQUE SPECIFICATIONS	19
		TURBOCHARGER	75

GENERAL INFORMATION

SECTIONAL VIEW – SOHC ENGINE for DIAMANTE

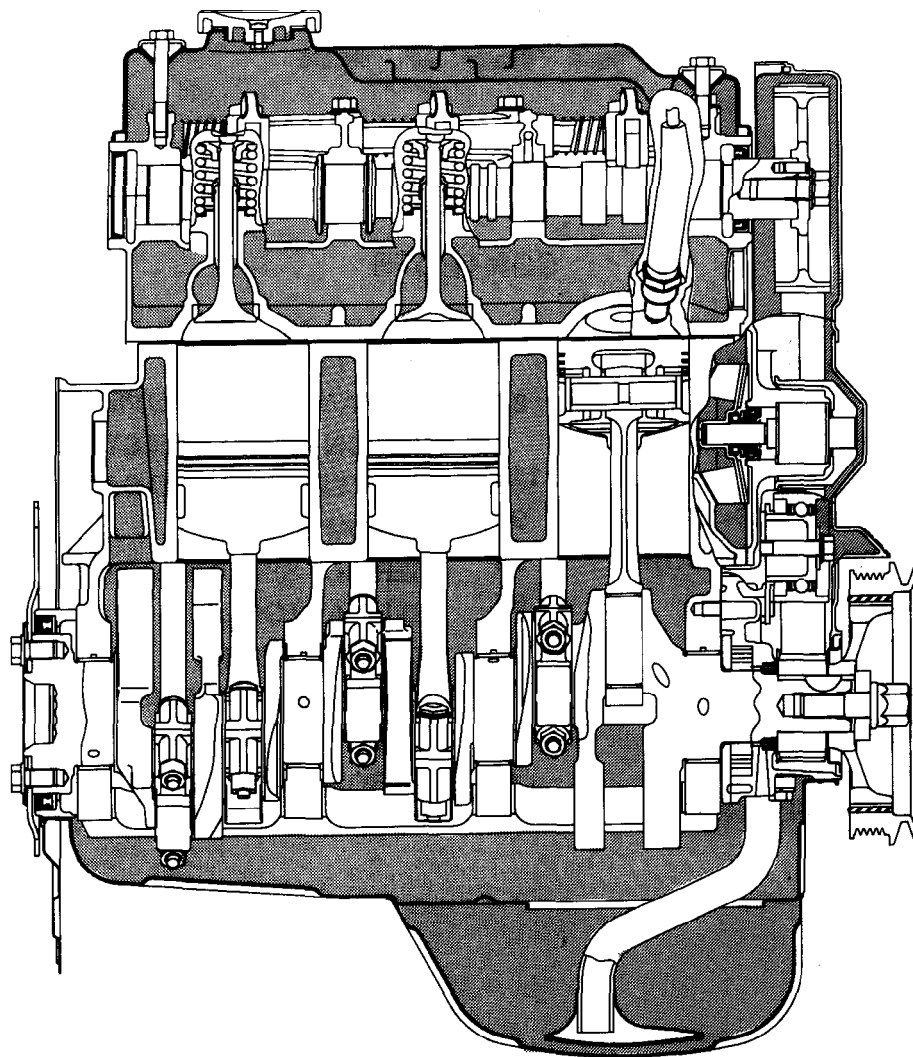

© 2001 GM Corp. All Rights Reserved.

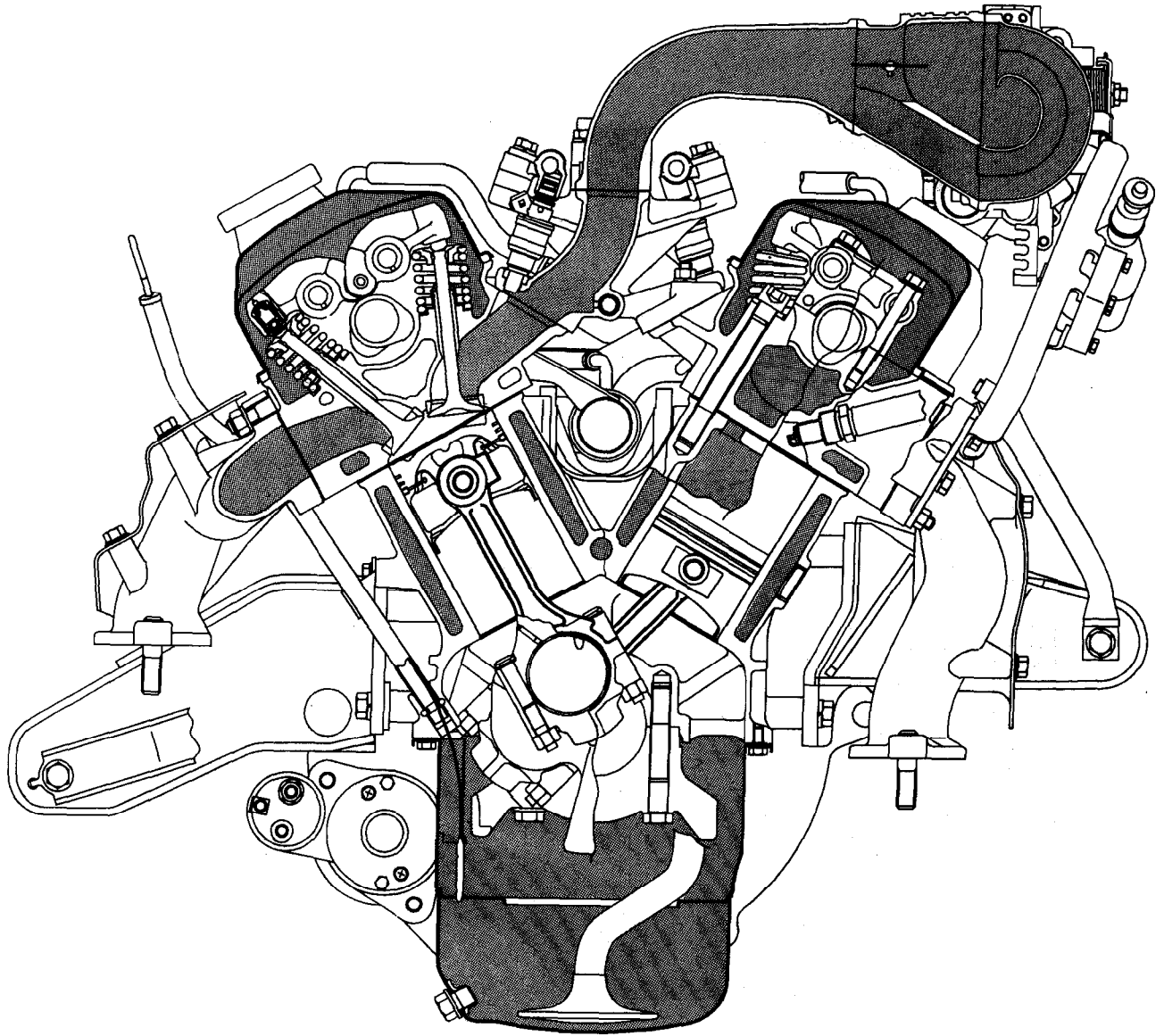

7EN0324

SECTIONAL VIEW – SOHC ENGINE for MONTERO AND TRUCK

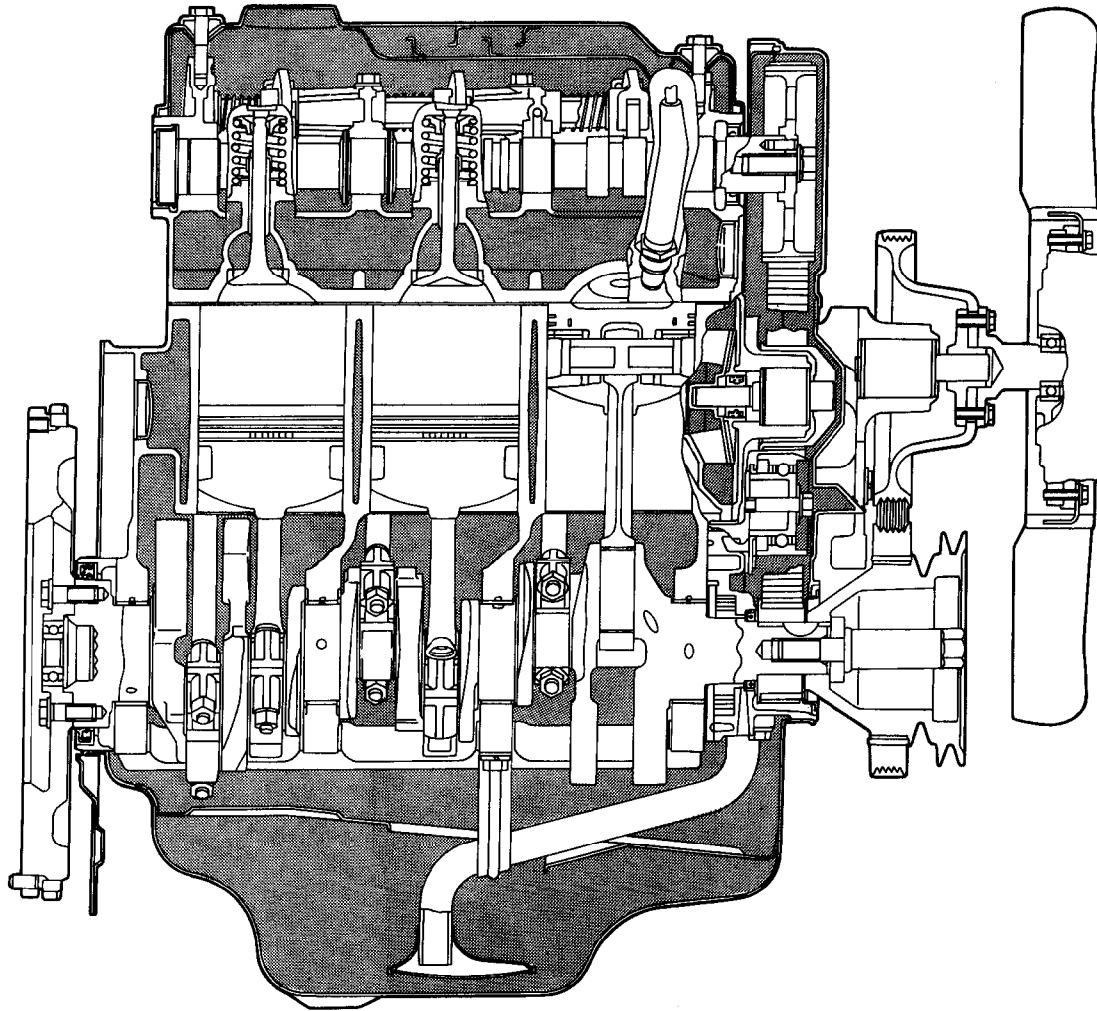

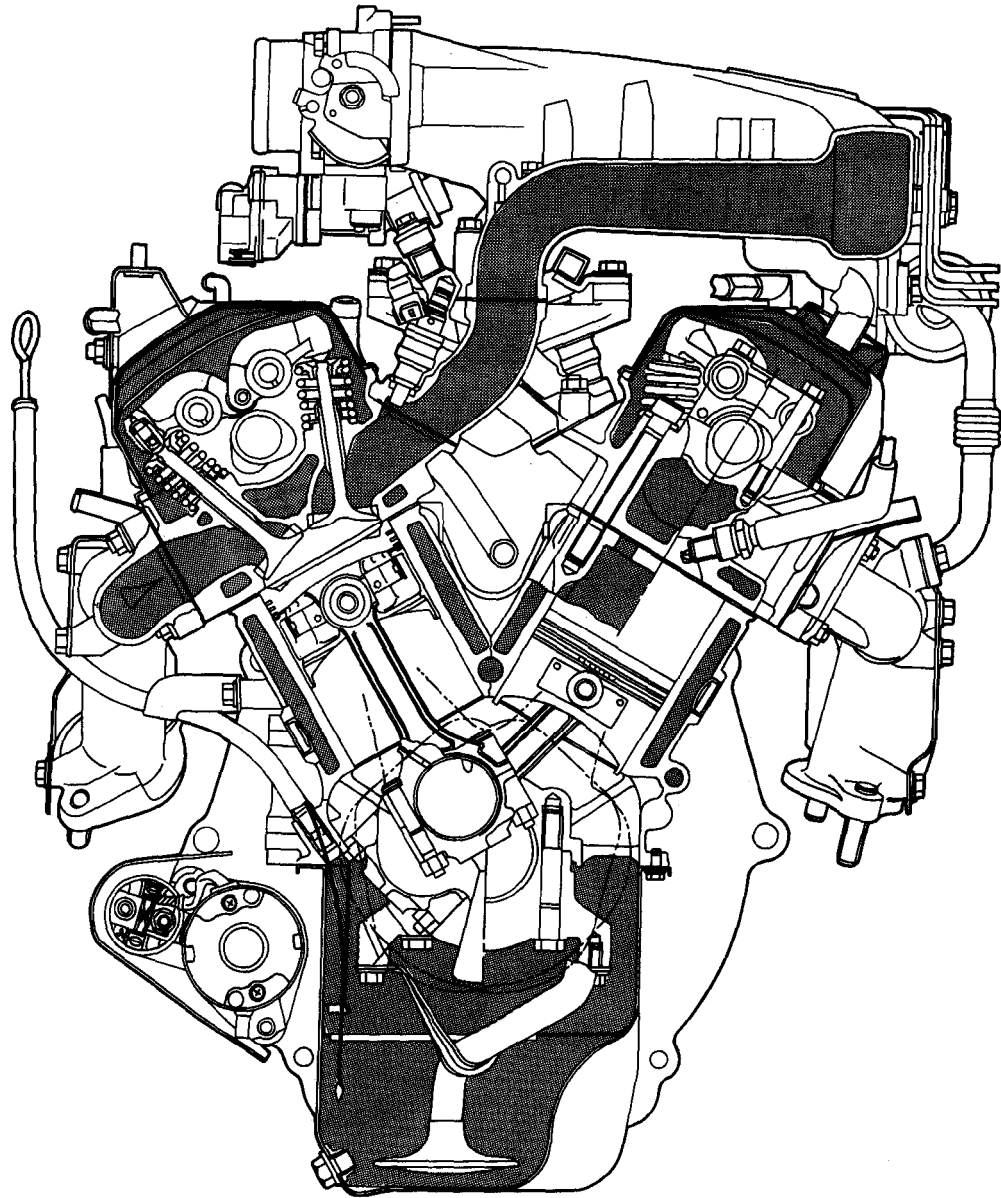

SECTIONAL VIEW – DOHC NON-TURBO ENGINE

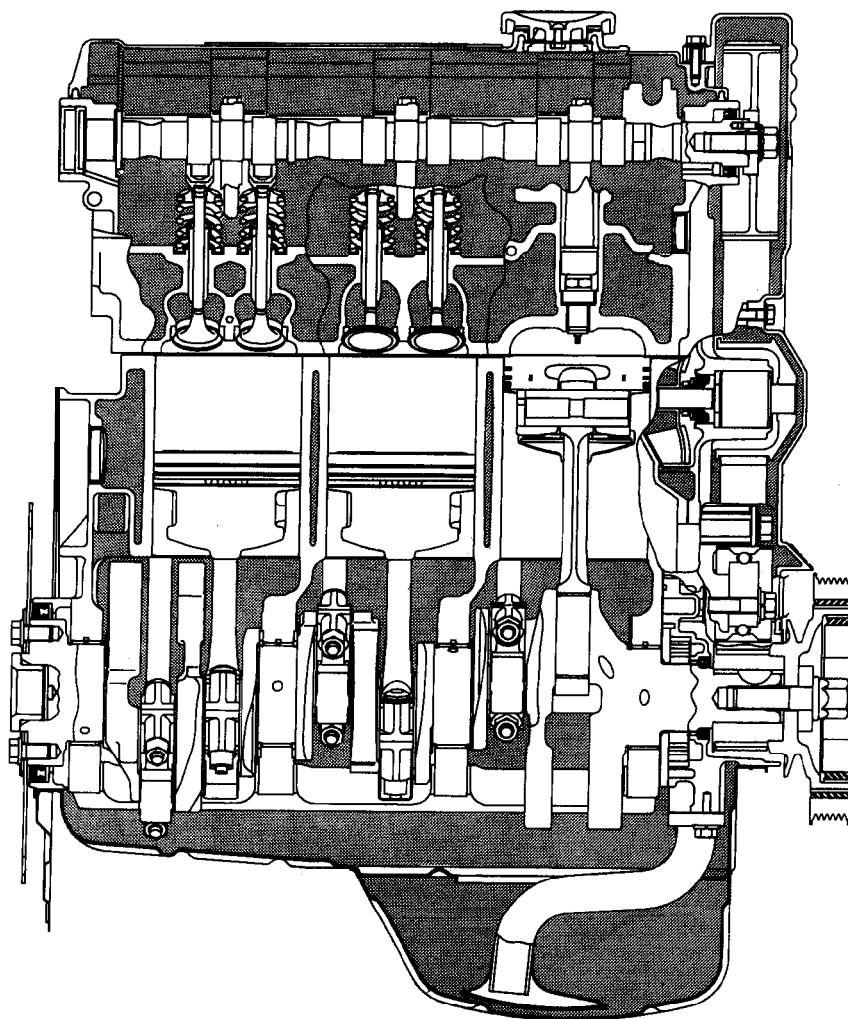

TSB Revision

5. VOLTAGE

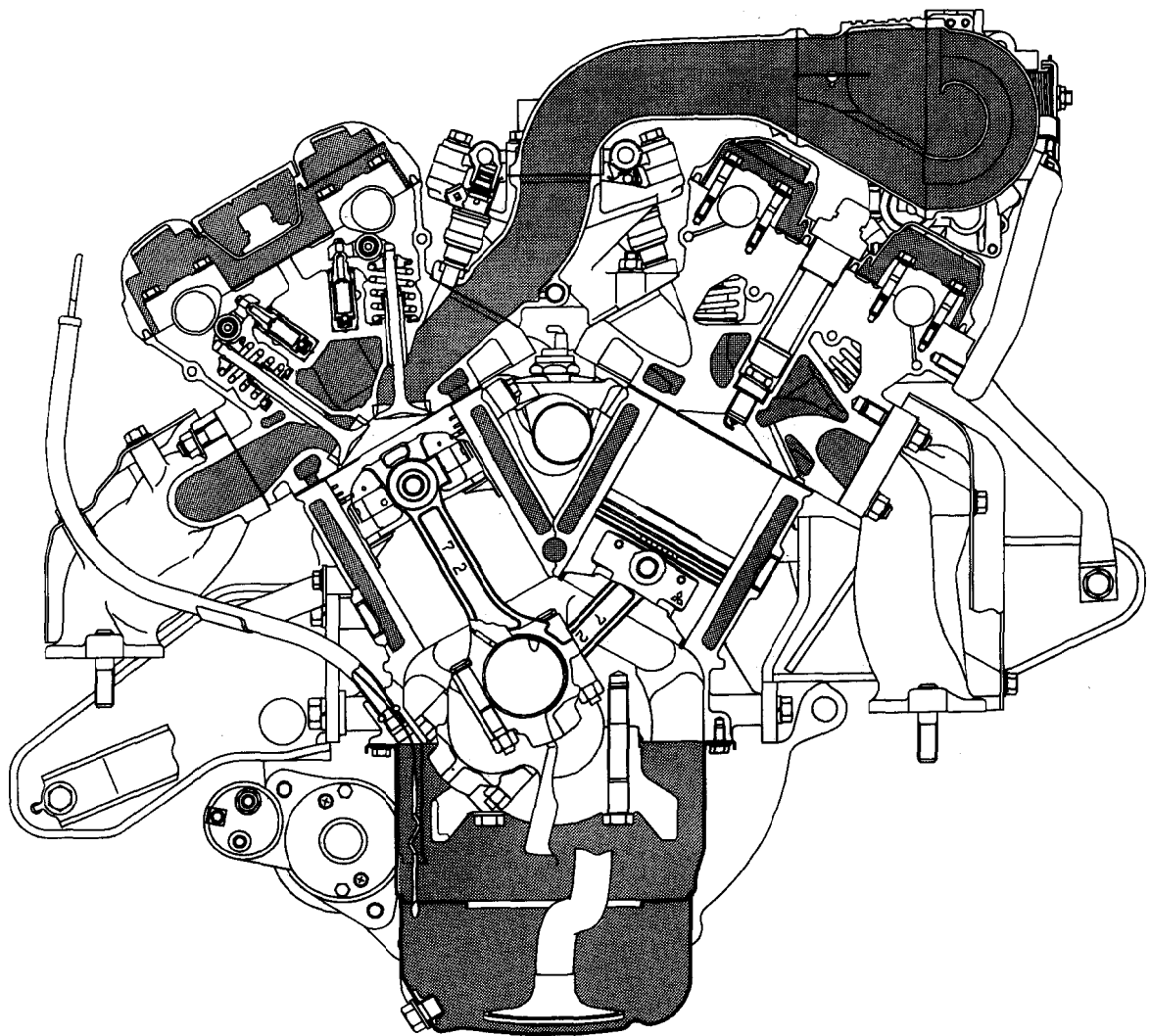

SECTIONAL VIEW – DOHC TURBO ENGINE

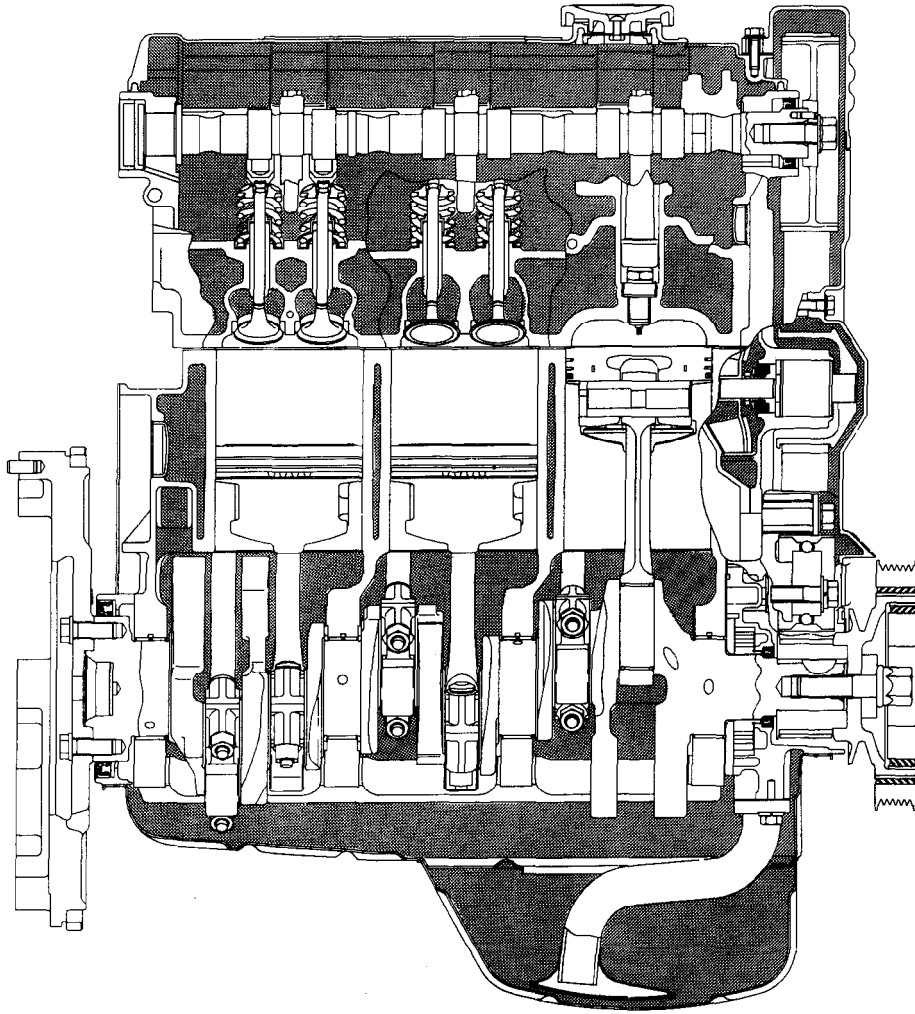

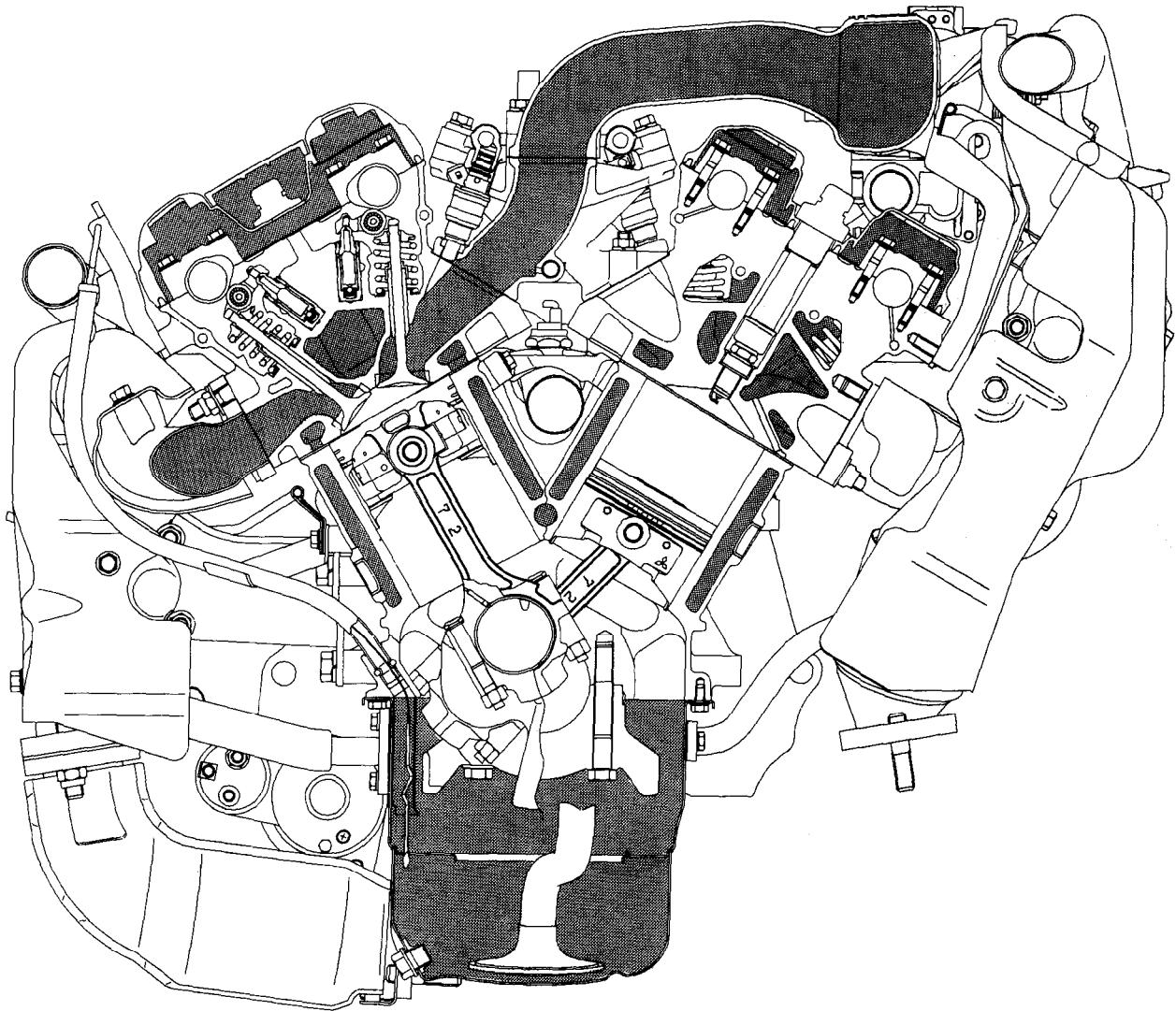

LUBRICATION SYSTEM – SOHC

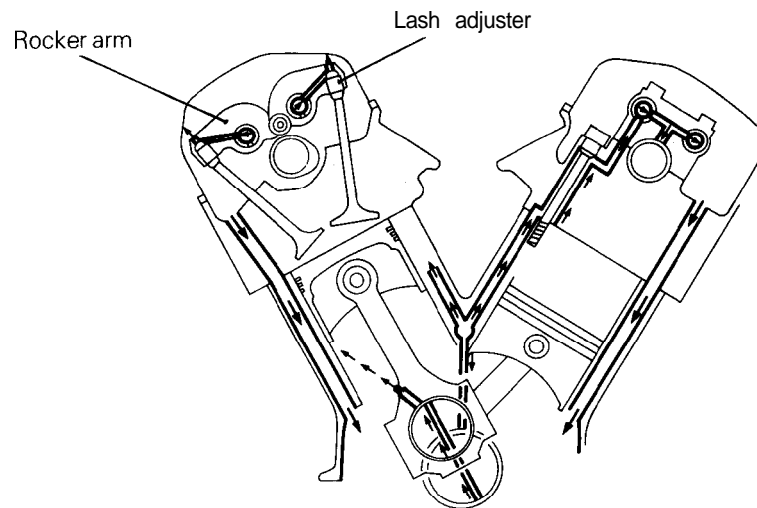
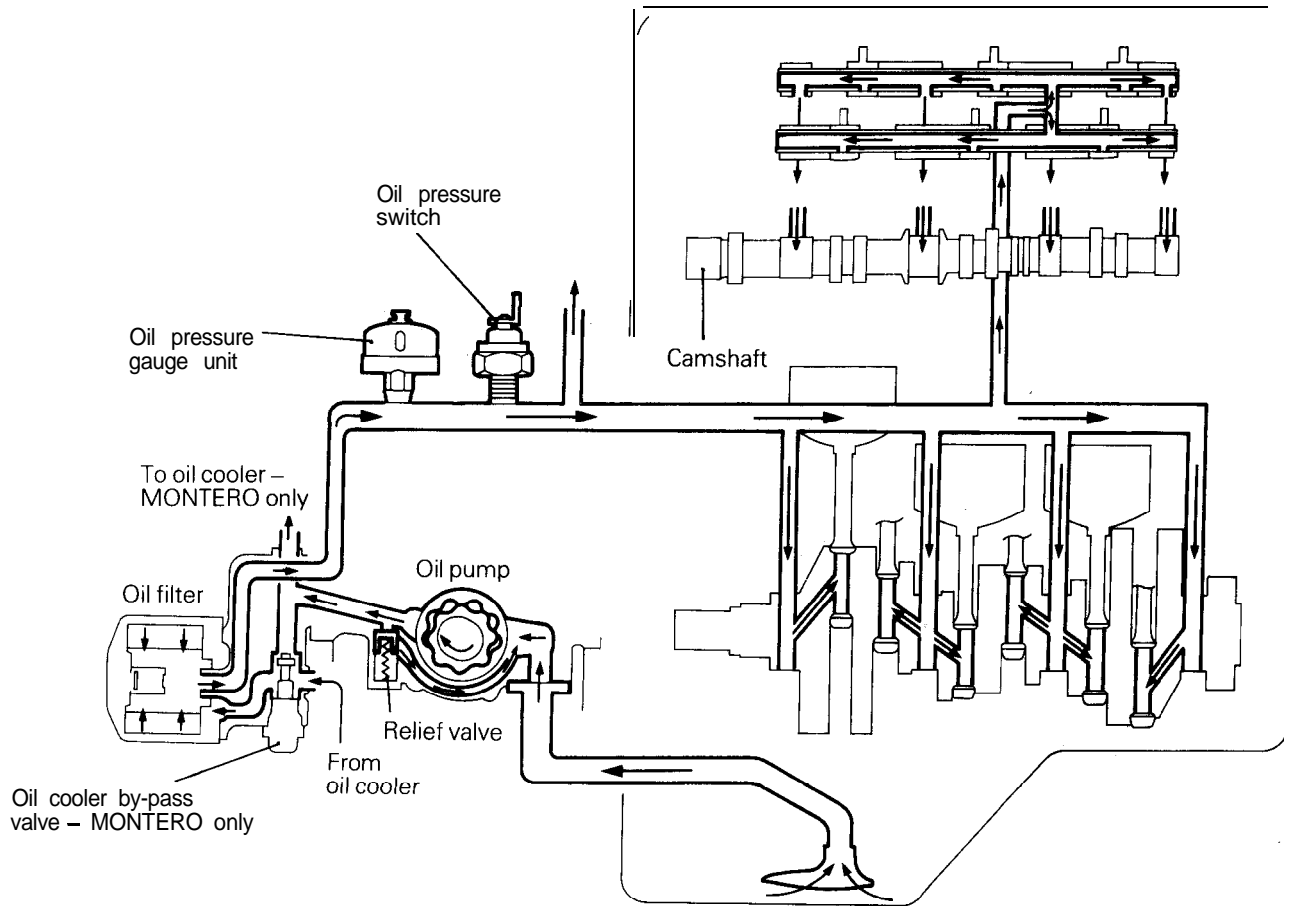

LUBRICATION SYSTEM – DOHC

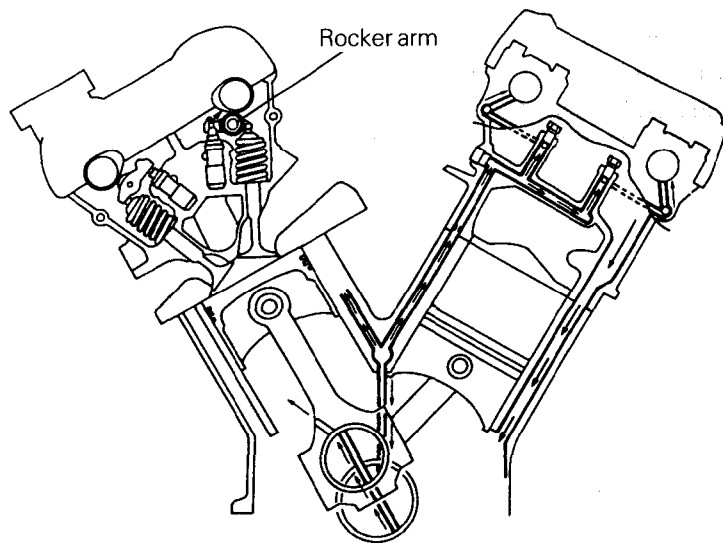
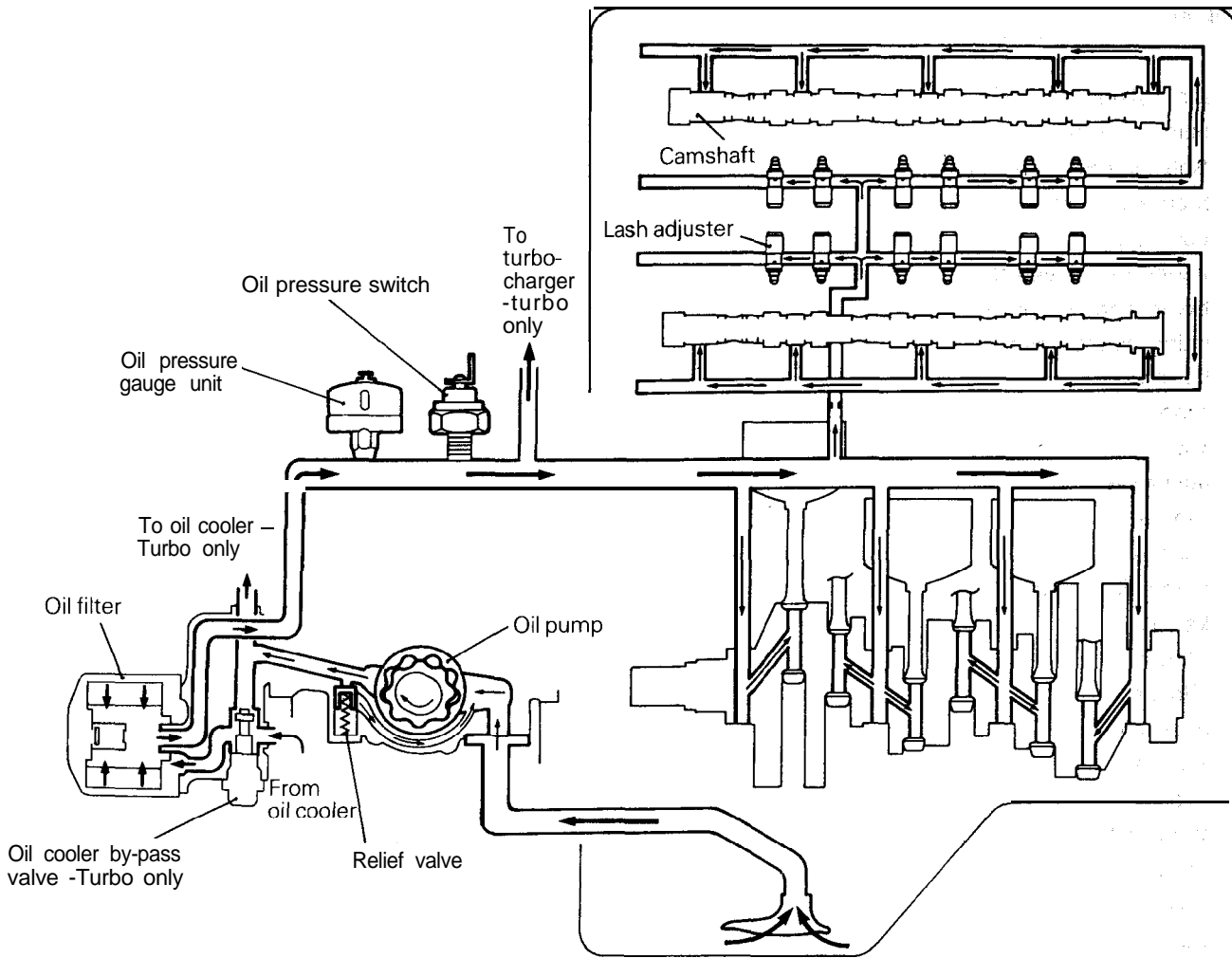

GENERAL SPECIFICATIONS

SOHC

Description	Specifications
Type	60°V, SOHC (per bank)
Number of cylinders	6
Combustion chamber	Compact type
Total displacement cm ³ (cu.in.)	2,972 (181.4)
Cylinder bore x stroke mm (in.)	91.1x 76.0 (3.59 x 2.99)
Compression ratio	
Front wheel drive vehicle	10.0
Rear wheel drive vehicle	8.9
Valve timing: Front wheel drive	
Intake valve	
Opens	16° BTDC
Closes	66° ABDC
Exhaust valve	
Opens	56° BBDC
Closes	26° ATDC
Valve timing: Rear wheel drive	
Intake valve	
Opens	19° BTDC
Closes	59° ABDC
Exhaust valve	
Opens	59° BBDC
Closes	19° ATDC
Lubrication system	Pressure feed, full-flow filtration
Oil pump type	Trochoid type
Cooling system	Water-cooled forced circulation
Water pump type	Centrifugal impeller type
EGR type	Single type
Injector type and number	Electromagnetic, 6
Injector identification mark For MONTERO and TRUCK	B210H
For DIAMANTE and TRUCK	N210H
Throttle bore mm (in.)	60 (2.362)
Throttle position sensor	Variable resistor type
Closed throttle position switch	Movable contact type

DOHC

Description	Specifications
Type	60°V, DOHC (per bank)
Number of cylinders	6
Combustion chamber	Compact type
Total displacement cm ³ (cu.in.)	2,972 (181.4)
Cylinder bore x stroke mm (in.)	91.1 x 76.0 (3.59 x 2.99)
Compression ratio Non-turbo	10.0
Turbo	8.0
Valve timing-Non-turbo	
Intake valve	
Opens	16° BTDC
Closes	55° ABDC
Exhaust valve	
Opens	48° BBDC
Closes	15° ATDC
Valve timing -Turbo	
Intake valve	
Opens	16° BTDC
Closes	55° ABDC
Exhaust valve	
Opens	50° BBDC
Closes	17° ATDC
Lubrication system	Pressure feed, full-flow filtration
Oil pump type	Trochoid type
Cooling system	Water-cooled forced circulation
Water pump type	Centrifugal impeller type
EGR type	Single type
Injector type	Electromagnetic, 6
Injector identification mark Non-turbo	BDH210
Turbo	BDL360
Throttle bore mm (in.)	60 (2.362)
Throttle position sensor	Variable resistor type
Closed throttle position switch	Movable contact type

SERVICE SPECIFICATIONS

mm (in.)

	Standard	Limit
Cylinder head – SOHC Flatness of gasket surface Grinding limit of gasket surface * Total resurfacing depth of both cylinder head and cylinder block Overall height Oversize rework dimensions of valve guide hole (both intake and exhaust) 0.05 (.002) 0.25 (.010) 0.50 (.020) Oversize rework dimension of valve seat hole Intake 0.3 (.012) 0.6 (.024) Exhaust 0.3 (.012) 0.6 (.024)	Less than 0.05 (.0019) 84 (3.31) 13.05 – 13.07 (.5138 – .5147) 13.25 – 13.27 (.5217 – .5224) 13.50 – 13.52 (.5315 – .5323) 44.30 – 44.33 (1.7441 – 1.7453) 44.60 – 44.63 (1.7559 – 1.7571) 38.30 – 38.33 (1.5079 – 1.5091) 38.60 – 38.63 (1.5197 – 1.5209)	0.2 (.008) *0.2 (.008)
Cylinder head – DOHC Flatness of gasket surface Grinding limit of gasket surface * Total resurfacing depth of both cylinder head and cylinder block Overall height Oversize rework dimensions of valve guide hole (both intake and exhaust) 0.05 (.002) 0.25 (.010) 0.50 (.020) Oversize rework dimension of valve seat hole Intake 0.3 (.012) 0.6 (.024) Exhaust 0.3 (.012) 0.6 (.024)	Less than 0.03 (.0012) 132 (5.20) 12.05 – 12.07 (.4744 – .4752) 12.25 – 12.27 (.4823 – .4831) 12.50 – 12.52 (.4921 – .4929) 36.30 – 36.33 (1.4291 – 1.4303) 36.60 – 36.63 (1.4409 – 1.4421) 33.30 – 33.33 (1.3110 – 1.3122) 33.60 – 33.63 (1.3228 – 1.3240)	0.2 (.008) *0.2 (.008)
Camshaft – SOHC Cam height Intake Exhaust Journal diameter Oil clearance Identification mark for DIAMANTE for MONTERO and TRUCK	41.25 (1.6240) 41.25 (1.6240) 34 (1.34) 0.05 – 0.09 (.0020 – .0035) H G	40.75 (1.6043) 40.75 (1.6043)

mm (in.)

	Standard	Limit
Camshaft – DOHC		
Cam height		
Intake	35.49 (1.3972)* ¹ , 34.91 (1.3744)* ²	34.99 (1.3776)* ¹ 34.41 (1.3547)**
Exhaust	35.20 (1.3858)* ¹ , 34.91 (1.3744)* ²	34.70 (1.3661)** 34.41 (1.3547)* ²
Journal diameter	26 (1.02)	
Oil clearance	0.05 – 0.09 (.020 – .0035)	
Rocker arm – SOHC		
I.D.	18.91 – 18.93 (.7445 – .7453)	
Rocker arm-to-shaft clearance	0.01 – 0.04 (.0004 – .0016)	0.10 (.004)
Rocker shaft – SOHC		
O.D.	18.89 – 18.90 (.7437 – .7441)	
Overall length	333.5 (13.130)	
Valve – SOHC		
Overall length		
Intake	102.97 (4.0539)	
Exhaust	102.67 (4.0421)	
Stem diameter		
Intake	7.96 – 7.98 (.3134 – .3142)	
Exhaust	7.93-7.95 (.3122 – .3130)	
Face angle	45° – 45.5°	
Stem-to guide clearance		
Intake	0.03 – 0.06 (.0012 – .0024)	0.10 (.0039)
Exhaust	0.05 – 0.09 (.0020 – .0035)	0.15 (.0059)
Thickness of valve head (Margin)		
Intake	1.2 (.047)	0.7 (.028)
Exhaust	2.0 (.079)	1.5 (.059)
Valve – DOHC		
Overall length		
Intake	106.28 (4.1842)	
Exhaust	105.40 (4.1496)	
Stem diameter		
Intake	6.57 – 6.58 (.2587 – .2591)	
Exhaust	6.53 – 6.55 (.2571 – .2579)	
Face angle	45° – 45.5°	
Stem-to guide clearance		
Intake	0.02 – 0.05 (.0008 – .0020)	0.10 (.0039)
Exhaust	0.05 – 0.09 (.0020 – .0035)	0.15 (.0059)
Thickness of valve head (Margin)		
Intake	1.0 (.039)	0.5 (.019)
Exhaust	1.5 (.059)	1.0 (.039)

NOTE

*1= Up to 1992 models

*2= from 1993 models

mm (in.)

	Standard	Limit
Valve spring – SOHC		
Free length	49.8 (1.961)	48.8 (1.921)
Load/Installed height N/mm (lbs./in.)	329/40.4 (72.5/1.591)	
Out-of-squareness	Less than 2°	4°
Valve spring – DOHC		
Free length	45.2 (1.780)* ¹ , 46.4 (1.827)* ²	44.2 (1.740)* ¹ 45.4 (1.787)**
Load/installed height N/mm (lbs.in.)	240/37.9 (52.9/1.492)	
Out-of-squareness	Less than 2°	4°
Valve guide – SOHC		
Overall length		
Intake	44 (1.73)	
Exhaust	48 (1.89)	
I.D.	8.00 – 8.02 (.315 – .316)	
O.D.	13.06 – 13.07 (.5142 – .5146)	
Service size	0.05 (.002), 0.25 (.010) 0.50 (.020) Oversize	
Valve guide – DOHC		
Overall length		
Intake	45.5 (1.791)	
Exhaust	50.5 (1.988)	
I.D.	6.60 – 6.62 (.2598 – .2607)	
O.D.	12.06 – 12.07 (.4748 – .4752)	
Service size	0.05 (.002), 0.25 (.010) 0.50 (.020) Oversize	
Valve seat		
Seat angle	44 – 44.5°	
Valve contact width	0.9 – 1.3 (.035 – .051)	
Sinkage		0.2
Service size	0.30 (.012), 0.60 (.024) Oversize	
Piston – SOHC		
O.D.	91.1 (3.587)	
Piston-to-cylinder clearance	0.02 – 0.04 (.0008 – .0016)	
Service size	0.25 (.010), 0.50 (.020) 0.75 (.030), 1.00 (.039) Oversize	
Piston – DOHC		
O.D.	91.1 (3.587)	
Piston-to-cylinder clearance	0.02 – 0.04 (.0008 – .0016)	
Service size	0.25 (.010), 0.50 (.020) 0.75 (.030), 1.00 (.039) Oversize	

NOTE

O.D. = Outer Diameter

I.D. = Inner Diameter

*1 = Up to 1992 models

*2 = From 1993 models

mm (in.)

	Standard	Limit
Piston ring – SOHC		
End gap		
No. 1 ring	0.30 – 0.45 (.0118 – .0177)	0.8 (.031)
No. 2 ring		
Front wheel drive vehicle	0.45 – 0.60 (.0177 – .0236)	0.8 (.031)
Rear wheel drive vehicle	0.25 – 0.45 (.0098 – .0177)	0.8 (.031)
Oil ring		
Front wheel drive vehicle	0.20 – 0.60 (.0079 – .0236)	1.0 (.039)
Rear wheel drive vehicle	0.20 – 0.70 (.0079 – .0276)	1.0 (.039)
Ring to ring groove clearance		
No.1 ring		
Front wheel drive vehicle	0.03 – 0.07 (.0012 – .0028)	0.1 (.004)
Rear wheel drive vehicle	0.05 – 0.09 (.0020 – .0035)	0.1 (.004)
No.2 ring	0.02 – 0.06 (.0008 – .0024)	0.1 (.004)
Piston ring – DOHC		
End gap		
No. 1 ring	0.30 – 0.45 (.0118 – .0177)	0.8 (.031)
No. 2 ring	0.45 – 0.60 (.0177 – .0236)	1.0 (.039)
Oil ring	0.20 – 0.70 (.0079 – .0276)	1.0 (.039)
Ring to ring groove clearance		
No. 1 ring	0.03 – 0.07 (.0012 – .0028)	0.1 (.004)
No. 2 ring	0.02 – 0.06 (.0008 – .0024)	0.1 (.004)
Piston pin		
O.D.	22.001 – 22.007 (.8662 – .8664)	
Press-in load N (lbs.)	75.00 – 175.00 (1,653 – 3,858)	
Press-in temperature	Room temperature	
Connecting rod		
Big end center-to-small end center length	140.9 – 141.0	
Bend	0.05 (.0020) or less	
Twist	0.1 (.004) or less	
Big end side clearance	0.10 – 0.25 (.0039 – .0098)	0.4 (.016)
Crankshaft		
End play	0.05 – 0.25 (.0020 – .0098)	0.3 (.012)
Journal O.D.	60 (2.36)	
Pin O.D.	50 (1.97)	
Out-of-roundness of journal and pin		
Two-camshaft engine	Less than 0.005 (.0002)	
Four-camshaft engine	Less than 0.003 (.0001)	
Taper of journal and pin	Less than 0.005 (.0002)	
Oil clearance of journal	0.020 – 0.050 (.0008 – .0020)	0.1 (.004)
Oil clearance of pin	0.020 – 0.050 (.0008 – .0020)	0.1 (.004)

NOTE
O.D. = Outer Diameter

mm (in.)





	Standard	Limit
Cylinder block Cylinder bore Flatness of gasket surface Grinding limit of top surface * Total resurfacing depth of both cylinder head and cylinder block	91.1 (3.587) 0.05 (.002)	“0.2 (.008)
Oil pump Tip clearance Side clearance Body clearance	0.03 – 0.08 (.0012 – .0031) 0.04 – 0.10 (.0016 – .0039) 0.10 – 0.18 (.0040 – .0070)	0.35 (.0138)
Drive belt – SOHC for DIAMANTE Deflection New belt Used belt Tension gauge N (lbs.) New belt Used belt	4.0 – 5.0 (.157 – .197) 7.0 (.276) 700 – 900 (154 – 198) 500 (110)	
Drive belt – SOHC for MONTERO and TRUCK Deflection New belt Used belt Tension gauge N (lbs.) New belt Used belt	6.5 – 8.0 (.256 – .315) 9.0 (.354) 500 – 700 (110 – 154) 400 (88)	
Drive belt – DOHC Deflection New belt Used belt Tension N (lbs.) New belt Used belt	3.5 – 4.0 (.138 – .157) 4.0 – 5.0 (.157 – .197) 650 – 850 (143 – 187) 450 – 500 (99 – 132)	
Injector Coil resistance Non-turbo Ω Turbo Ω	13 – 16 at 20°C (68°F) 2 – 3 at 20°C (68°F)	
Idle air control motor Coil resistance Ω	28 – 33 at 20°C (68°F)	
Throttle position sensor Resistance $k\Omega$	3.5 – 6.5	
Accelerator pedal position sensor Resistance $k\Omega$	3.5-6.5	
Variable induction control motor Resistance Ω	5 – 35 at 20°C (68°F)	



	Nm	ft.lbs.
Exhaust manifold		
Oil level guide bolt	14	10
Heat protector bolt	14	10
Engine hanger bolt		
SOHC DIAMANTE	24	17
SOHC MONTERO AND TRUCK	19	14
DOHC NON-TURBO	13	9
Exhaust manifold nut		
SOHC	19	14
DOHC NON-TURBO	45	33
DOHC TURBO	30	22
Heater pipe bolt	12	9
Water pipe bolt	14	10
SOHC MONTERO AND TRUCK	12	9
Water pump bolt	24	17
Heat protector C	30	22
Turbocharger stay bolt	60	43
Exhaust fitting bolt	14	10
Oil pipe eye bolt	17	12
Flare nut	25	18
Water pipe eye bolt	31	22
Oil return pipe bolt	9	7
Turbocharger		
Turbocharger waste gate actuator bolt	12	9
Locker arms and camshafts - SOHC		
Oil filler bolt	9	7
Locker cover bolt	9	7
Distributor adaptor bolt	13	9
Locker arm shaft and bearing cap bolt	20	14
Camshafts, rocker arms and bearing caps- DOHC		
Crankshaft position sensor adaptor bolt	24	17
Bearing caps, front and rear bolt	20	14
Rear bearing cap bolts No. 2, 3, 4	11	8
Cylinder head and valve- SOHC		
Cylinder head bolt	110	80
Cylinder head and valve - DOHC		
Cylinder head bolt		
NON-TURBO	110	80
TURBO	125 → Back off → 125	90 → Back off → 90

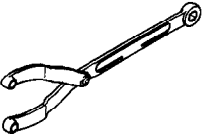
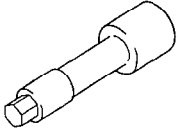
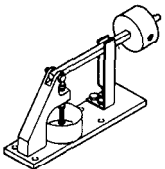

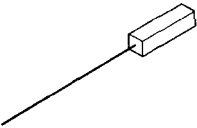
SEALANT

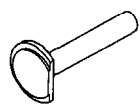
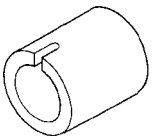
Items	Specified sealant	Quantity
Auto tensioner bolt -Turbo	3M ATD Part No. 8660	As required
Engine coolant temperature sensor	3M NUT Locking Part No.4171	As required
Engine coolant temperature gauge unit	3M ATD Part No.8660	As required
Rocker cover	3M ATD Part No.8660	As required
Bearing cap	3M NUT Locking Part No.4171	As required
Oil pressure switch	3M ATD Part No.8660	As required
Oil pressure gauge unit	3M ATD Part No.8660	As required
Oil pan	MITSUBISHI GENUINE Part No.MD970389	As required
Oil seal case	MITSUBISHI GENUINE Part No.MD970389	As required

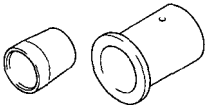
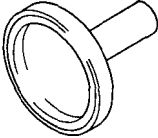
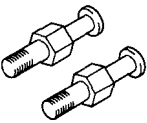
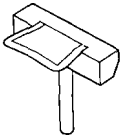
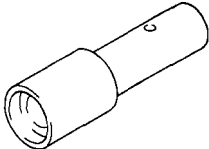
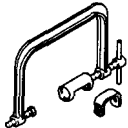
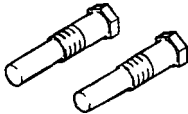
SPECIAL TOOLS

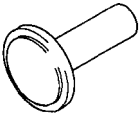
Tool	Number and tool name	Supersession	Application
	MB990767 End yoke holder Use with MD998719 or MD998754	MB990767-01 Use with MIT308239	Holding camshaft sprocket when loosening bolt For SOHC engine only
	MD998051 Cylinder head bolt wrench	MD998051-01	Loosening and tightening cylinder head bolts
	MD998440 Leak-down tester		Leak-down test of lash adjuster
	MD998441 Lash adjuster retainer		Bleeding of air inside adjuster For SOHC engine only
	MD998442 Air bleed wire		Air bleeding of auto lash adjuster
	MD998443 Lash adjuster holder (8)	MD998443-01	Supporting lash adjuster to prevent it from falling when rocker shaft assembly is removed or installed For SOHC engine only
	MD998713 Camshaft oil seal installer	MD998713-01	Installation of camshaft oil seal For SOHC engine only
	MD998714 Circular packing installer	MD998714-01 MB990938-01	Installation of circular packing For SOHC engine only
	MD998716 Crankshaft wrench	MD998716-01	Rotation of crankshaft when installing piston and timing belt For SOHC engine only

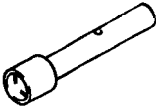
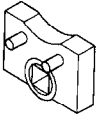
Tool	Number and tool name	Supersession	Application
	MD998717 Crankshaft front oil seal installer	MD998717-01	Installation of crankshaft front oil seal
	MD998718 Crankshaft rear oil seal installer	MD998718-01 Use with MB990938-01	Installation of crankshaft rear oil seal
	MD998719 Pulley holding pins (2)	MIT308239	Holding camshaft sprocket when loosening or torquing bolt For SOHC engine only
	MD998727 Oil pan remover		Removal of oil pan
	MD998729 Valve stem seal installer		Installation of valve stem seal For SOHC engine only
	MD998735 Valve spring compressor	MD998735-01	Removal and installation of valve and related parts
	MD998754 Pulley holding pins (2)	MIT308239	Holding crankshaft sprocket when loosening or torquing bolt
	MD998761 Camshaft oil seal installer	MD998761-01	Installation of camshaft oil seal For DOHC engine only
	MD998762 Circular packing installer	MD998762-01	Installation of circular packing For DOHC engine only

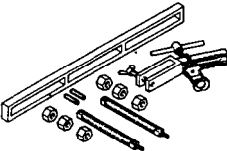
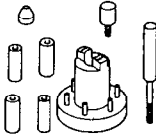
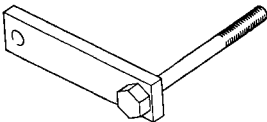
Tool	Number and tool name	Supersession	Application
	MD998763 Valve stem seal installer		Installation of valve stem seal For DOHC engine only
	MD998767 Tension pulley wrench	MD998752-01	Adjustment of timing belt tension For DOHC engine only
	MD998769 Crankshaft spacer		Rotation of crankshaft when installing piston and timing belt For DOHC engine only
	MD998772 Valve spring compressor		Compression of valve spring
	MD998780 Piston pin setting tool	MIT216941	Removal and installation of piston pin
	MD998781 Flywheel stopper		Installation of flywheel

GENERATOR AND DRIVE BELT

REMOVAL AND INSTALLATION – SOHC for DIAMANTE

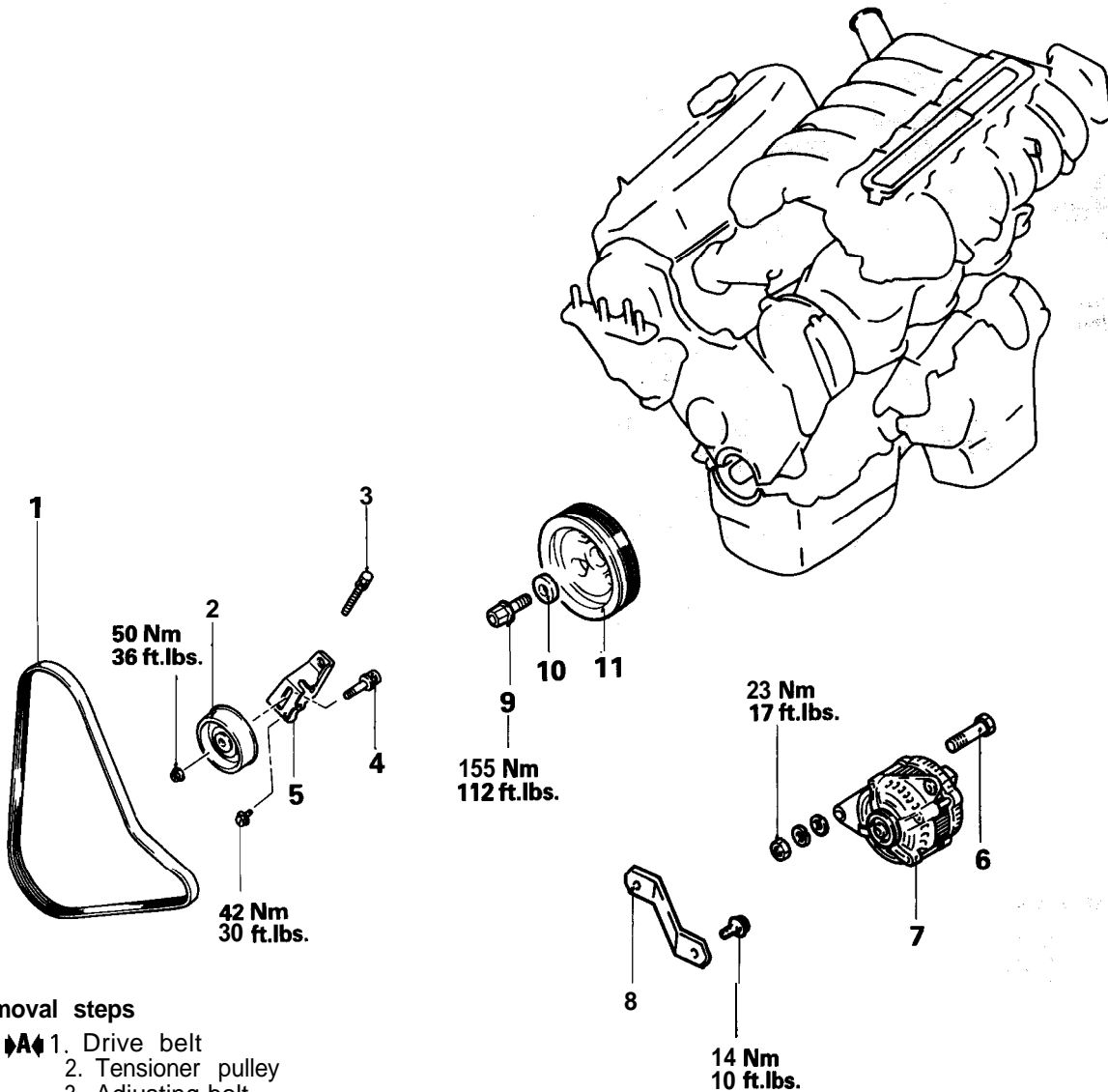

Removal steps

- ▶▶ 1. Drive belt
- 2. Tensioner pulley
- 3. Adjusting bolt
- 4. Adjusting stud
- 5. Tensioner bracket
- 6. Pivot bolt
- 7. Generator
- 8. Generator brace
- ◀▶▶▶ 9. Crankshaft bolt
- 10. Special washer
- 11. Crankshaft pulley

REMOVAL AND INSTALLATION – SOHC for MONTERO and TRUCK

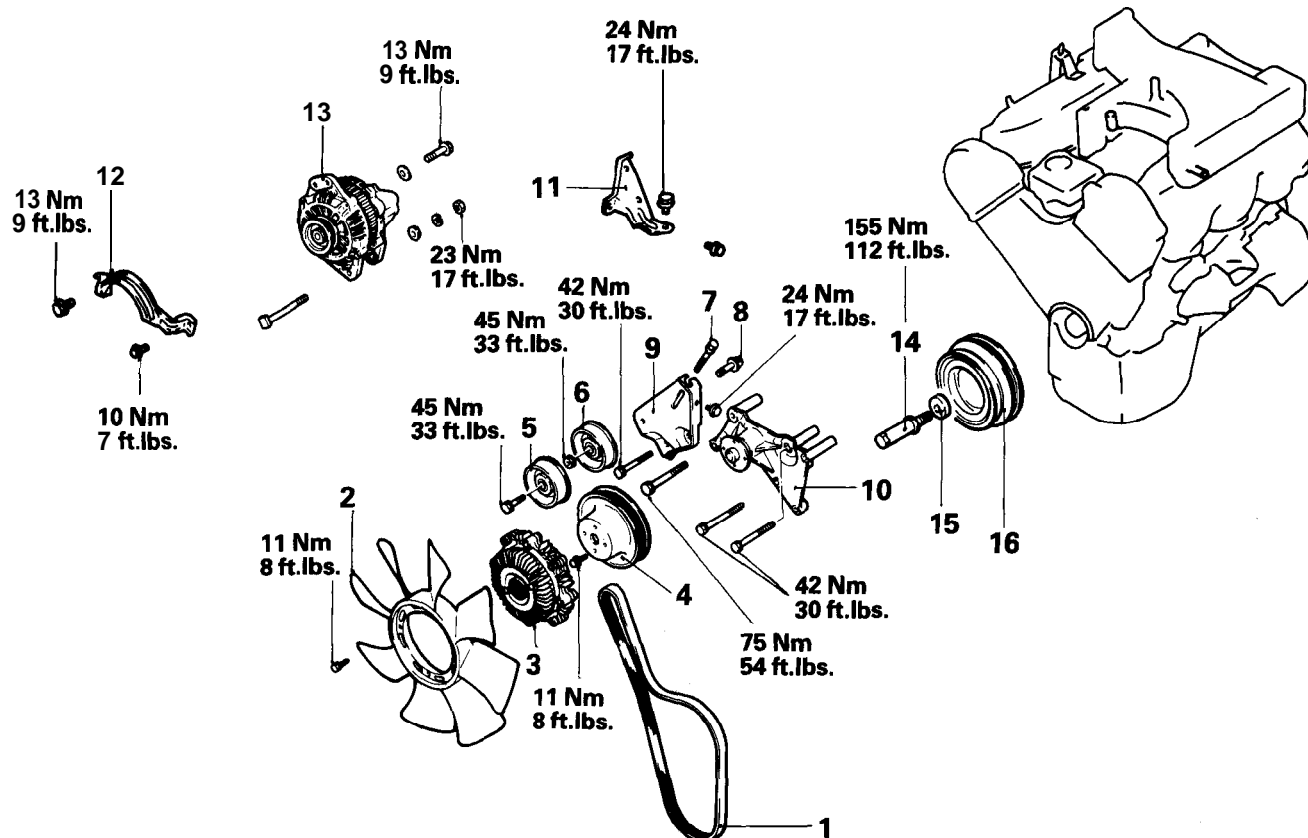

Removal steps

- ◆A◆ 1. Drive belt
- 2. Cooling fan
- 3. Fan clutch
- 4. Fan pulley
- 5. Idler pulley
- 6. Tensioner pulley
- 7. Adjusting bolt
- 8. Adjusting stud
- 9. Tensioner bracket
- 10. Cooling fan bracket assembly
- 11. Tensioner bracket stay
- 12. Generator brace
- 13. Generator
- ◁A▷ ◆B◆ 14. Crankshaft bolt
- 15. Special washer
- 16. Crankshaft pulley

REMOVAL AND INSTALLATION – DOHC

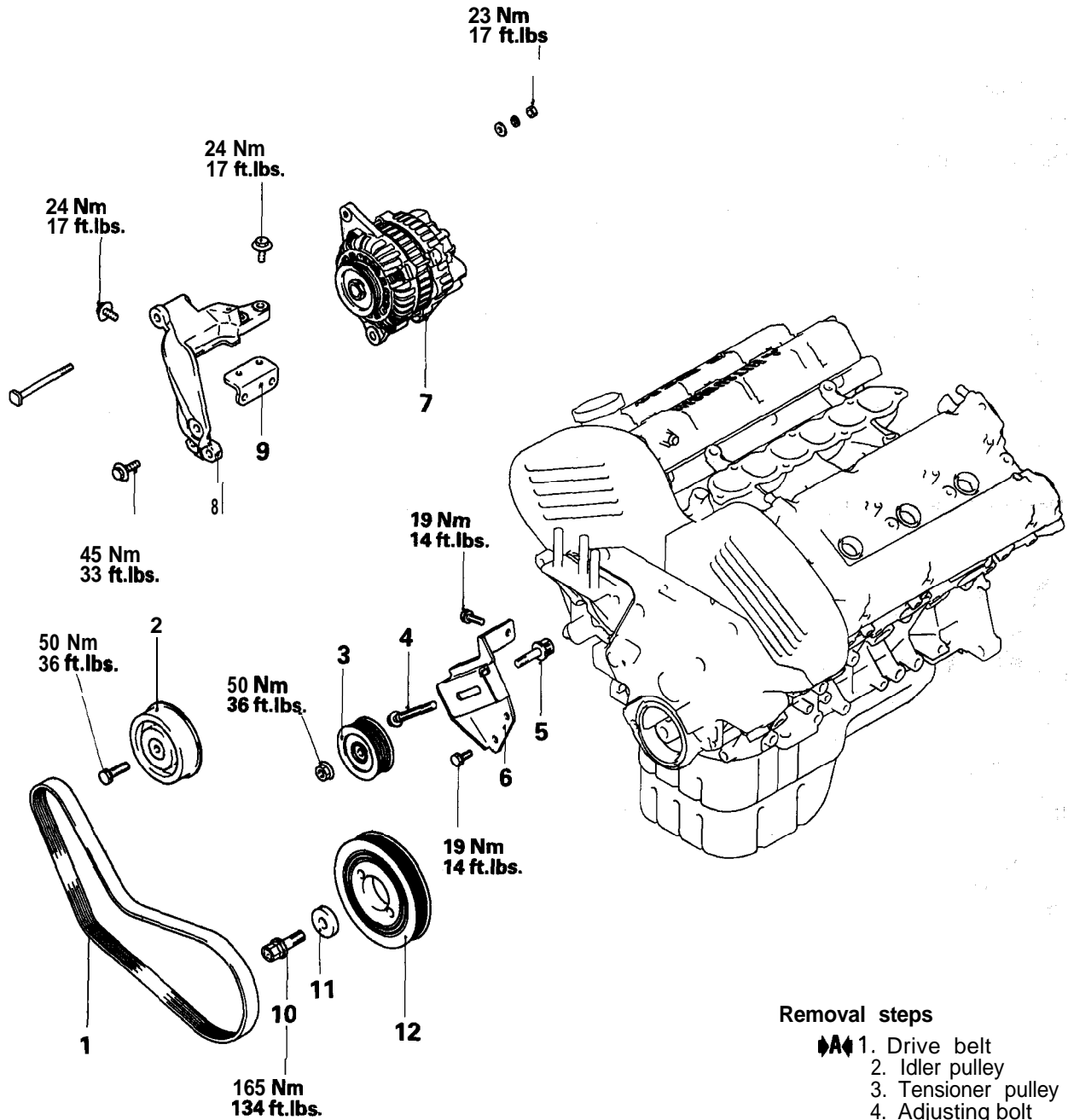

Removal steps

- ◆◆ 1. Drive belt
- 2. Idler pulley
- 3. Tensioner pulley
- 4. Adjusting bolt
- 5. Adjusting stud
- 6. Tensioner bracket
- 7. Generator
- 8. Generator bracket
- 9. Bracket
- ◀◆◆▶▶ 10. Crankshaft bolt
- 11. Special washer
- 12. Crankshaft pulley

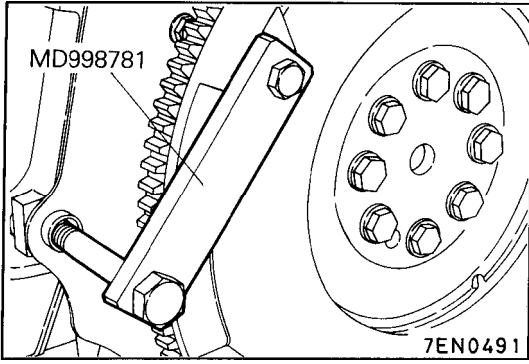

REMOVAL SERVICE POINT

CRANKSHAFT BOLT LOOSENING

- (1) Using the special tool, hold the drive plate or flywheel.
- (2) Remove the crankshaft bolt.

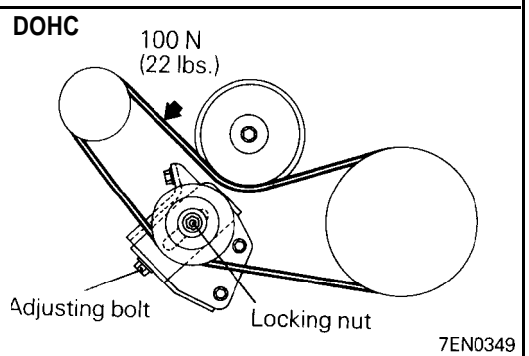
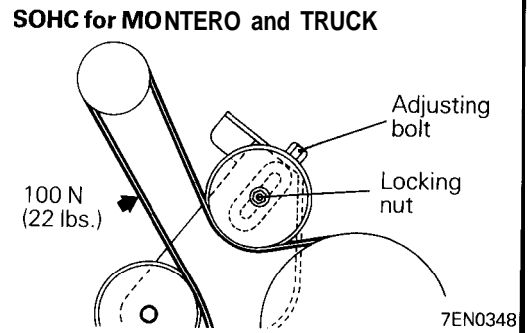
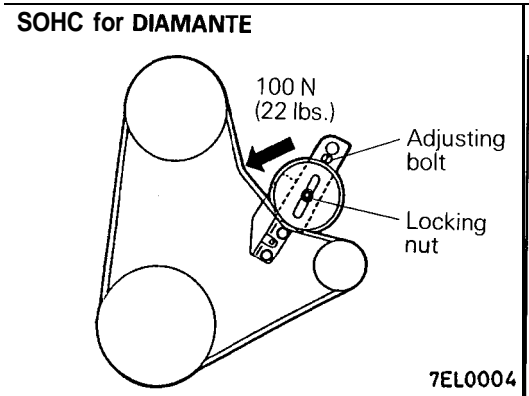

INSTALLATION SERVICE POINT

DRIVE BELT TENSION ADJUSTMENT

DRIVE BELT – TENSION CHART

Generator drive belt		Deflection mm (in.)	Tension gauge N (lbs.)
SOHC for DIAMANTE	New	4.5 (.16 – .20)	700 – 900 (154 – 198)
	Used	7 (.28)	500 (110)
SOHC for MONTERO and TRUCK	New	6.5 – 8.0 (.26 – .32)	500 – 700 (110 – 154)
	Used	9 (.35)	400 (88)
DOHC	New	3.5 – 4.0 (.14 – .16)	650 – 850 (143 – 187)
	Used	4 – 5 (.16 – .20)	450 – 600 (99 – 132)

- (1) Loosen the tensioner pulley locking nut.
- (2) Tighten the adjusting bolt to adjust the belt deflection to the specification shown in the chart.

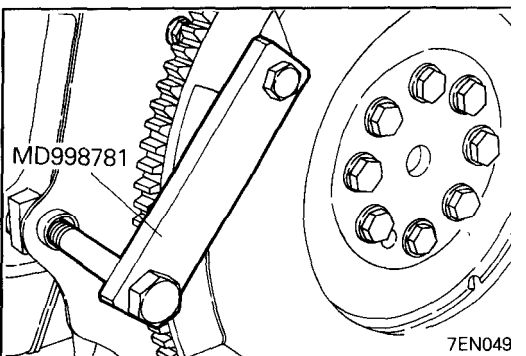
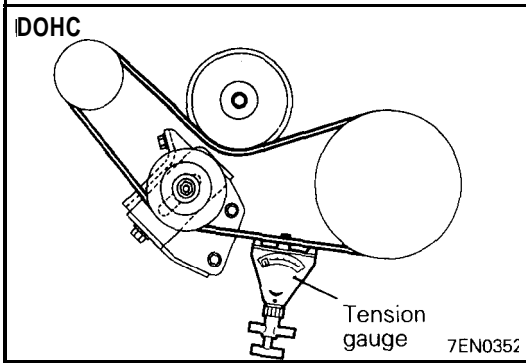
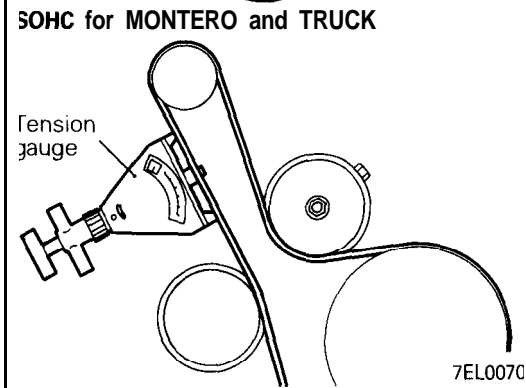
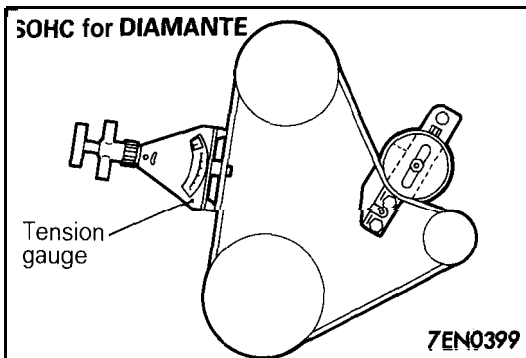

- (3) If you use a tension gauge, tighten the adjusting bolt to adjust the belt tension to the specification shown in the chart.

⚡ CRANKSHAFT BOLT TIGHTENING

- (1) Using the special tool, hold the drive plate or flywheel.
- (2) Install the crankshaft bolt.

INTAKE MANIFOLD PLENUM AND THROTTLE BODY

REMOVAL AND INSTALLATION – SOHC for DIAMANTE

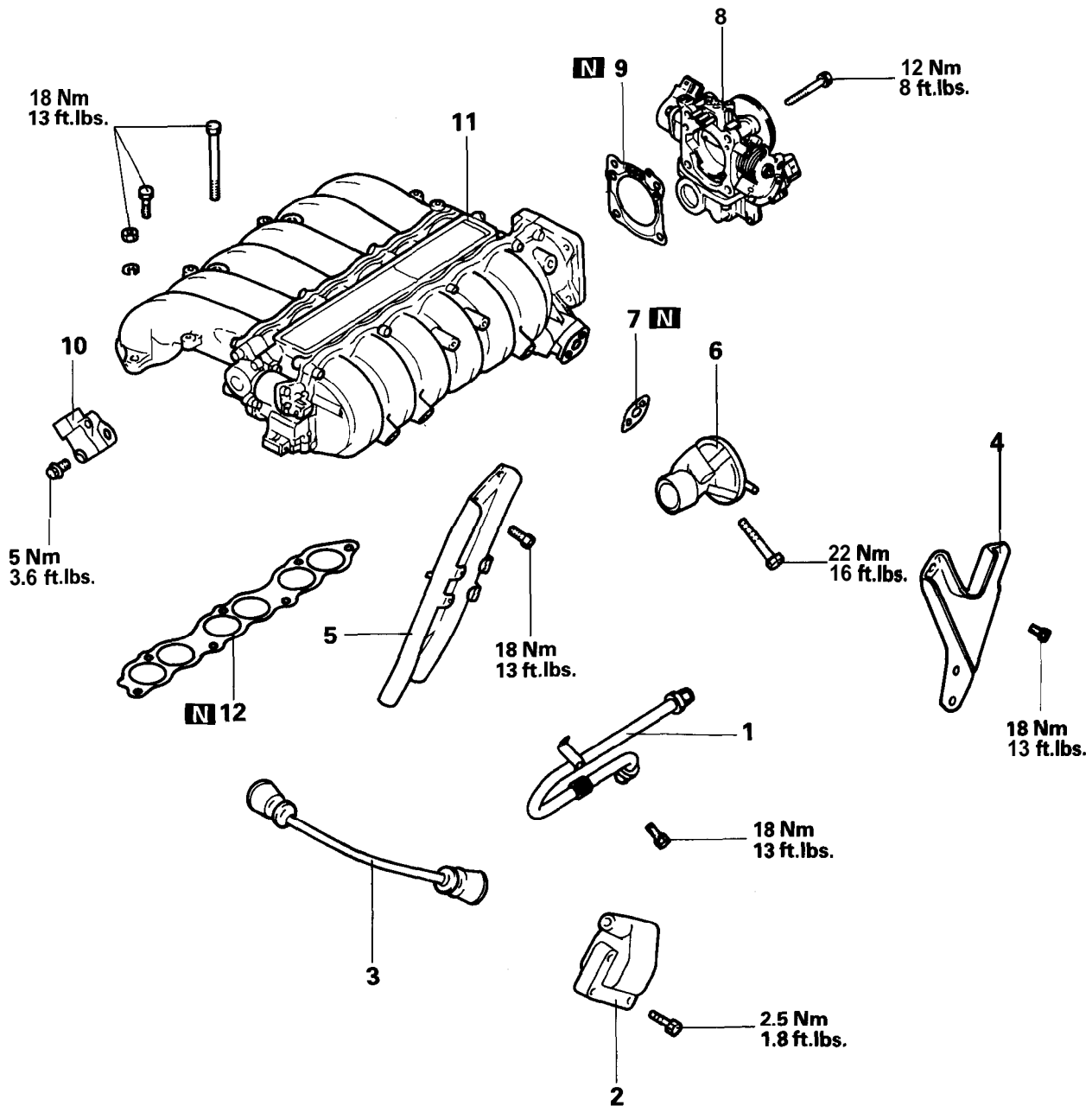

Removal steps

1. EGR pipe ————— For California
2. Ignition coil
3. High tension cable
4. Intake manifold plenum stay, rear
5. Intake manifold plenum stay, front
6. EGR valve
7. EGR valve aasket } For California
8. Throttle body
9. Throttle body gasket
10. Ignition power transistor
11. Intake manifold plenum
12. Intake manifold plenum gasket

REMOVAL AND INSTALLATION – SOHC for MONTERO and TRUCK

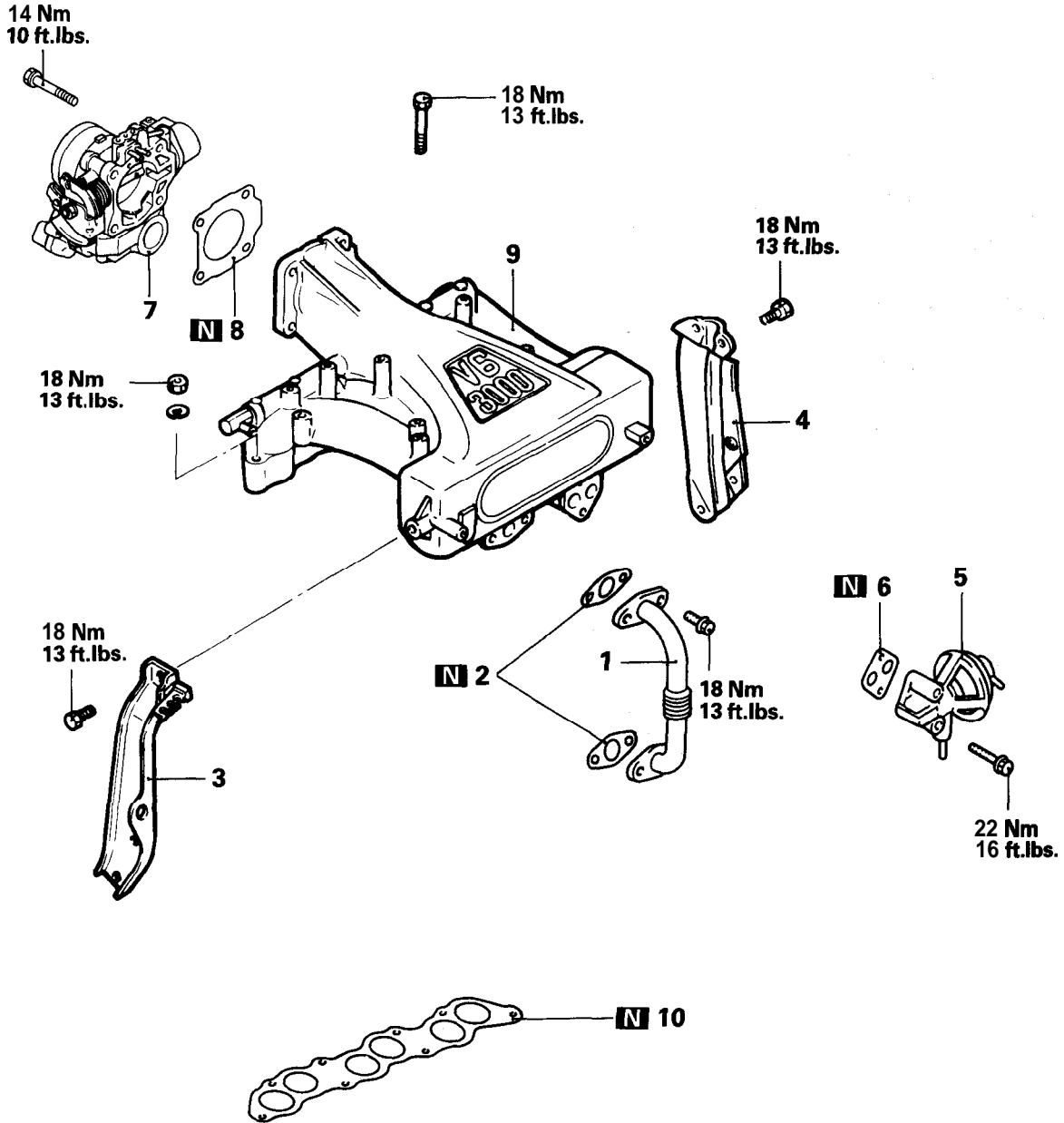

Removal steps

- 1. EGR pipe
 - 2. EGR pipe gasket
 - 3. Intake manifold plenum stay, rear
 - 4. Intake manifold plenum stay, front
 - 5. EGR valve
 - 6. EGR valve gasket
 - 7. Throttle body
 - 8. Throttle body gasket
 - 9. Intake manifold plenum
 - 10. Intake manifold plenum gasket
- } For California
- } For California

REMOVAL AND INSTALLATION – DOHC NON-TURBO

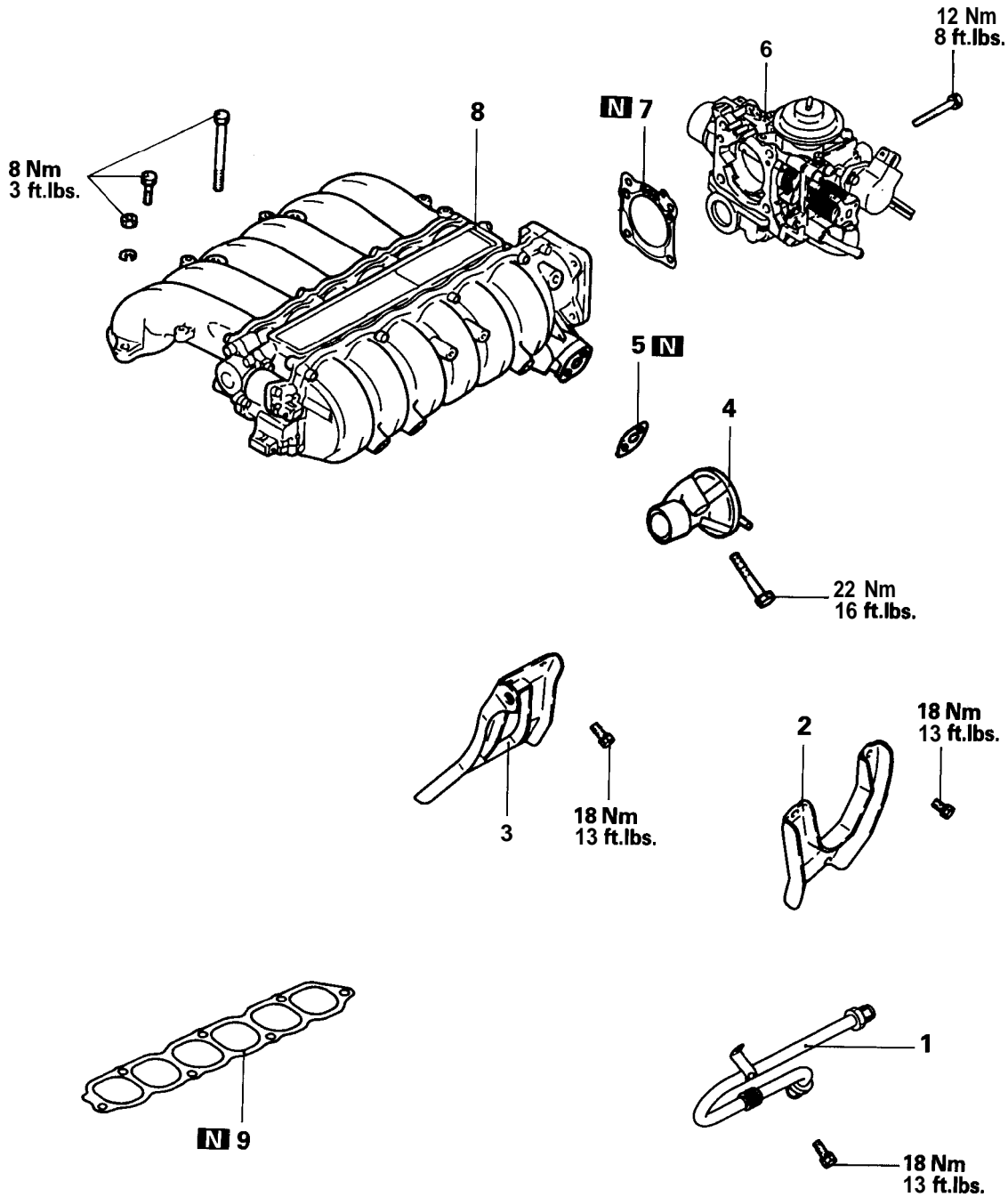

Removal steps

1. EGR pipe ————— For California
2. Intake manifold plenum stay, rear
3. Intake manifold plenum stay, front
5. EGR valve
6. EGR valve gasket } For California
7. Throttle body
8. Intake manifold plenum
9. Intake manifold plenum gasket

REMOVAL AND FUEL SYSTEM – DOHC TURBO

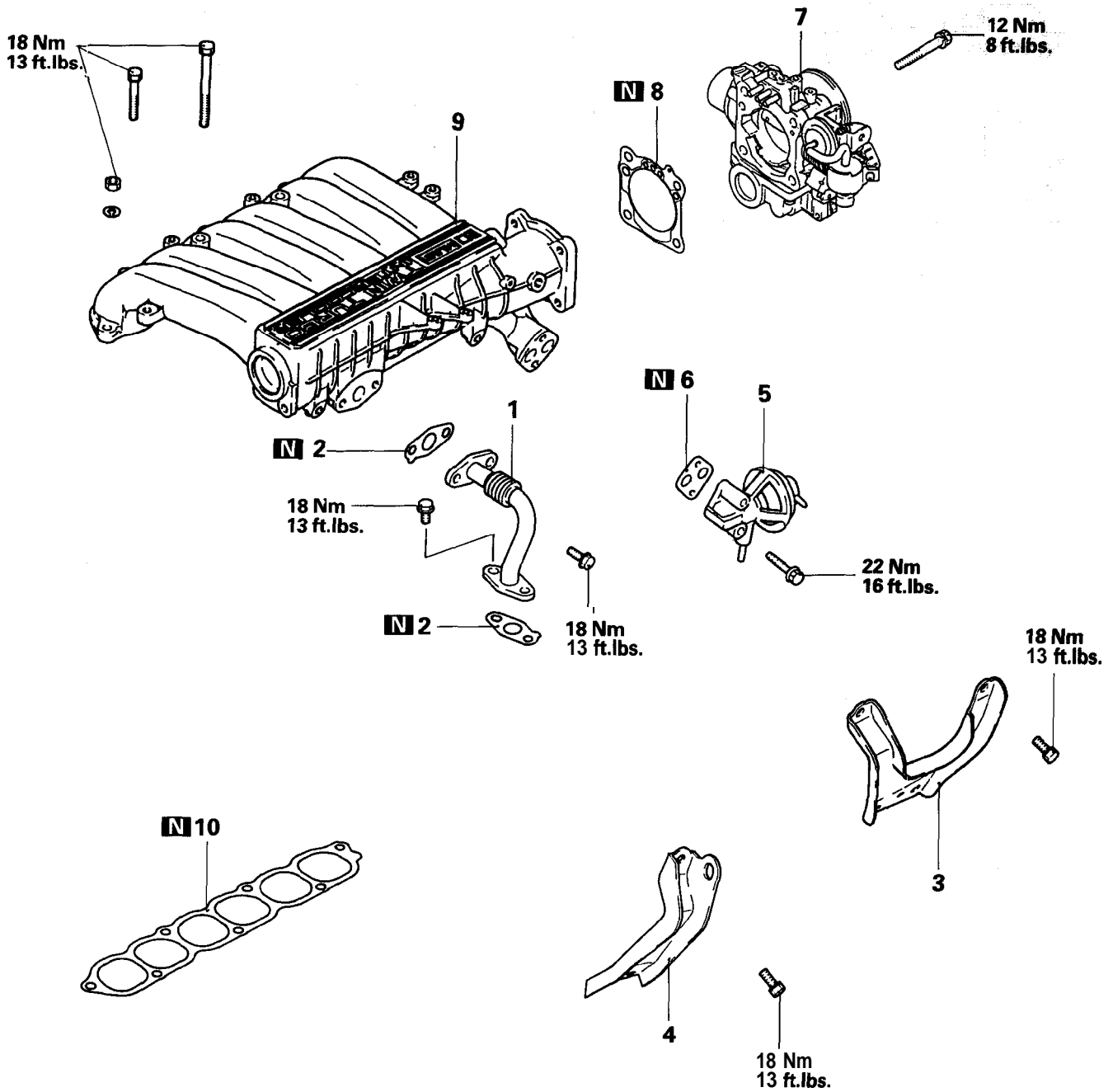

Removal steps

- | | |
|---------------------------------------|------------------|
| 1. EGR pipe | } For California |
| 2. EGR pipe gasket | |
| 3. Intake manifold plenum stay, rear | |
| 4. Intake manifold plenum stay, front | |
| 5. EGR valve | } For California |
| 6. EGR valve gasket | |
| 7. Throttle body | |
| 8. Throttle body gasket | |
| 9. Intake manifold plenum | |
| 10. Intake manifold plenum gasket | |

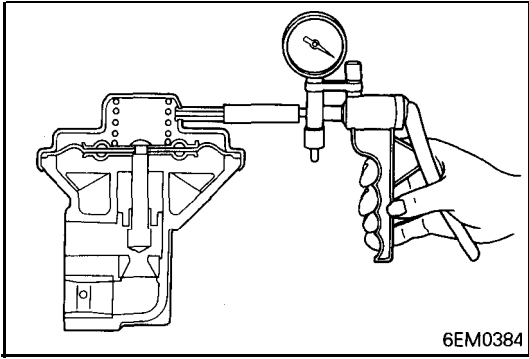
**INSPECTION****EGR VALVE**

- (1) Check the EGR valve for sticking or carbon deposits.
If such conditions exist, clean or replace the EGR valve.
- (2) Connect a hand vacuum pump to the nipple of the EGR valve and plug other nipple.
- (3) If there is vacuum leakage, replace the EGR valve.
- (4) Blow air in from one passage of the EGR to check its condition as follows.

Applying vacuum	Result
45 mmHg (1.8 in.Hg.) or less	Air does not blow through
230 mmHg (9.1 in.Hg.) or more	Air blow through

THROTTLE BODY

DISASSEMBLY AND REASSEMBLY – SOHC for DIAMANTE, DOHC NON-TURBO

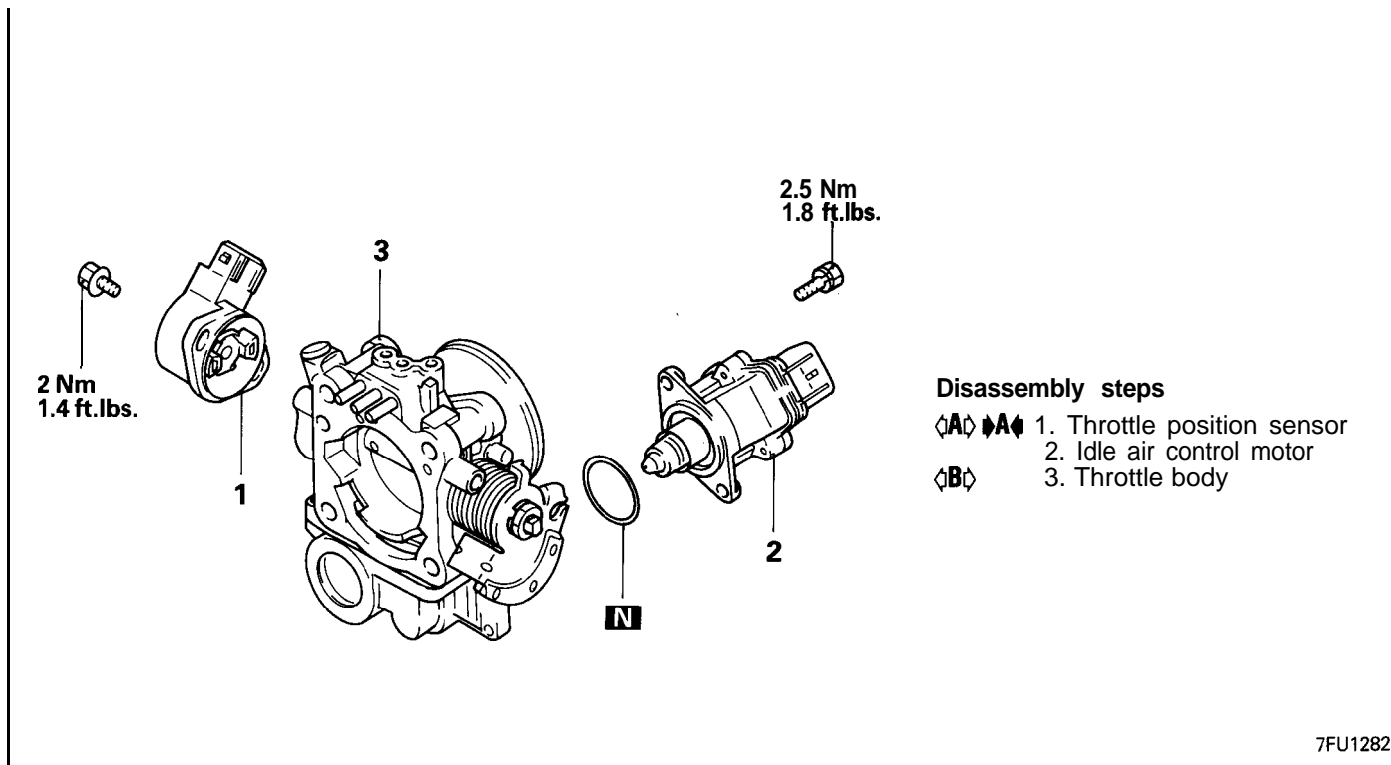

7FU1282

DISASSEMBLY AND REASSEMBLY – For VEHICLES with TRACTION CONTROL

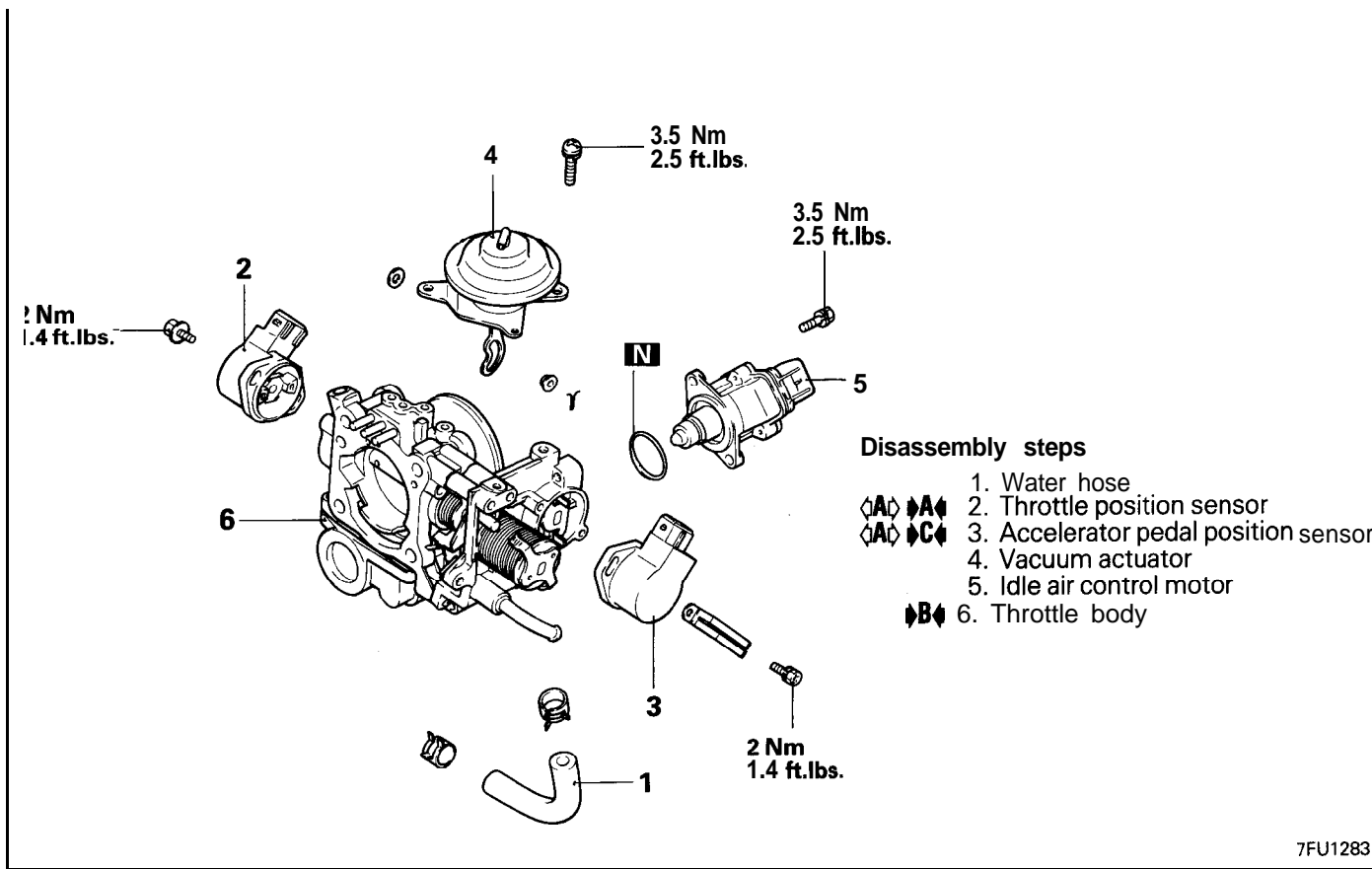

7FU1283

DISASSEMBLY AND REASSEMBLY – DOHC TURBO

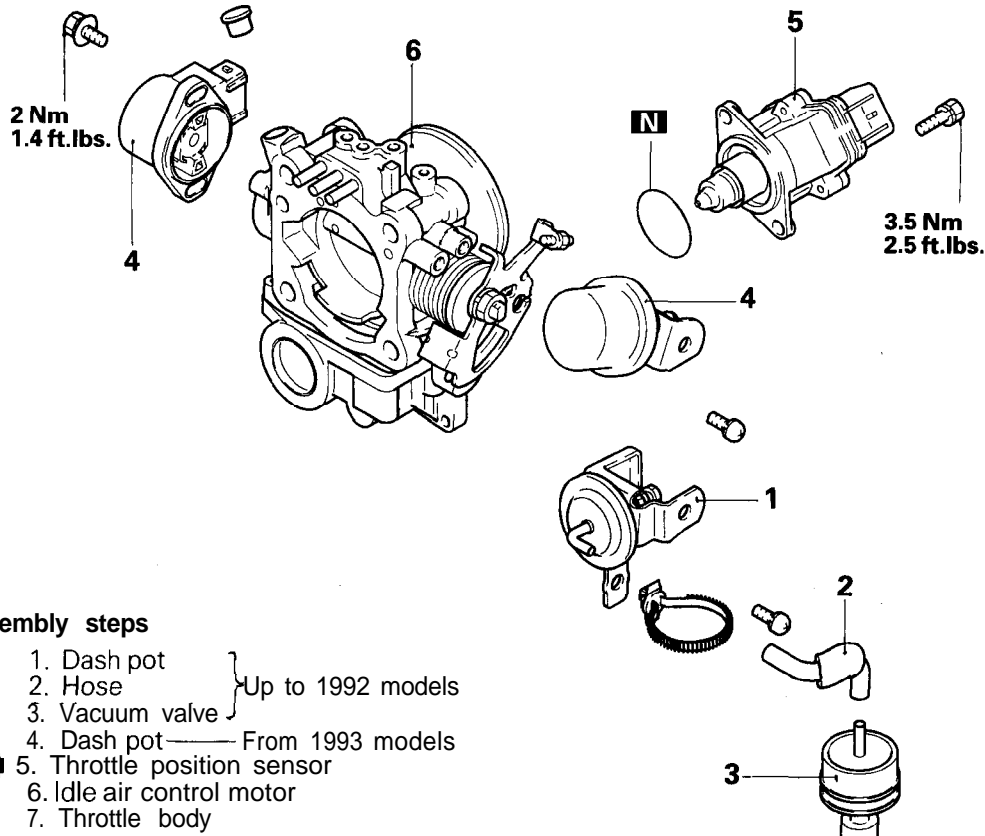

Disassembly steps

- 1. Dash pot
 - 2. Hose
 - 3. Vacuum valve
 - 4. Dash pot
 - 5. Throttle position sensor
 - 6. Idle air control motor
 - 7. Throttle body
- } Up to 1992 models
- } From 1993 models

7EN0525

DISASSEMBLY AND REASSEMBLY – SOHC for MONTERO and TRUCK

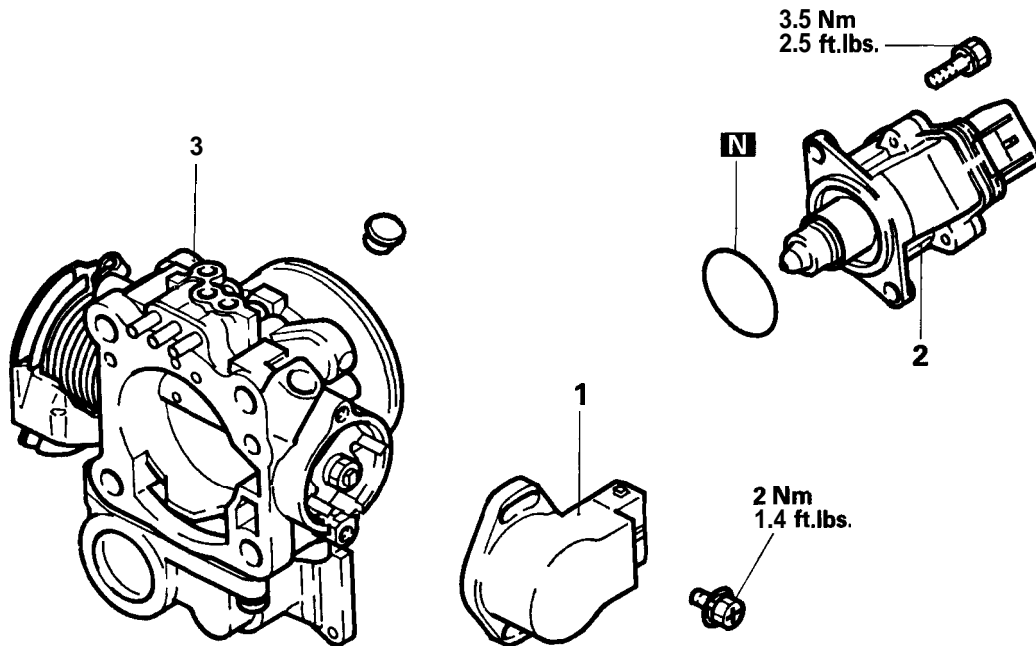

Disassembly steps

- 1. Throttle position sensor
(Within closed throttle position switch)
- 2. Idle air control motor assembly
- 3. Throttle body

7FU0532

DISASSEMBLY SERVICE POINTS**◁A▷ THROTTLE POSITION SENSOR, ACCELERATOR PEDAL POSITION SENSOR AND IDLE AIR CONTROL MOTOR REMOVAL**

- (1) Do not disassemble the sensor and motor.
- (2) Do not clean the sensor and motor by dipping them into the solvent. Clean them with shop towel.

◁B▷ THROTTLE BODY REMOVAL

- (1) Do not remove the throttle valve.
- (2) Check if the vacuum port or passage is clogged. Use compressed air to clean the vacuum passage.

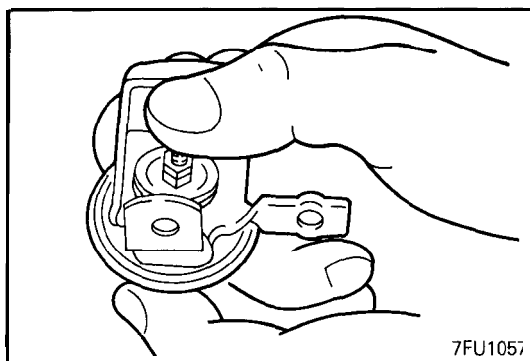
**INSPECTION****DASH POT – DOHC TURBO**

Up to 1992 models

- (1) Push the rod of the dash pot all the way in and close the nipple with the fingers,
- (2) If the rod does not protrude after releasing it, the dash pot is functioning normally.
- (3) If the rod protrudes, a broken diaphragm is suspected. Therefore, replace the dash pot.

From 1993 models

- (1) Push the dash pot rod in lightly and confirm the resistance.

NOTE

1. Resistance increases as the rod is pushed harder.
2. If the rod can be pushed in with no resistance, either the diaphragm or check valve is faulty.

- (2) Release finger and confirm that the rod returns to its original position quickly.

NOTE

If the rod returns slowly, the check valve is faulty.

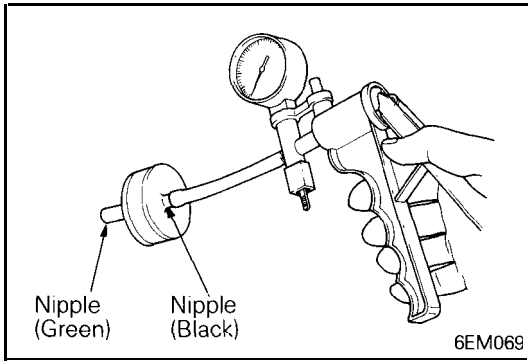

VACUUM VALVE – DOHC TURBO

Up to 1992 models

- (1) Remove the filter from the vacuum valve.
- (2) Connect a hand vacuum pump to the black nipple of the vacuum valve.
- (3) With the other nipple closed by the finger, apply a negative pressure of 500 mmHg (19.7 in.Hg.) to make sure that the negative pressure is maintained.
- (4) Let go your finger and make sure that the negative pressure leaks out gradually.
- (5) Disconnect the hand vacuum pump and connect it to the green nipple.
- (6) Make sure that the negative pressure leaks out as soon as it is applied.
- (7) Remove the hand vacuum pump from the valve.
- (8) Install the filter onto the black nipple of the valve.

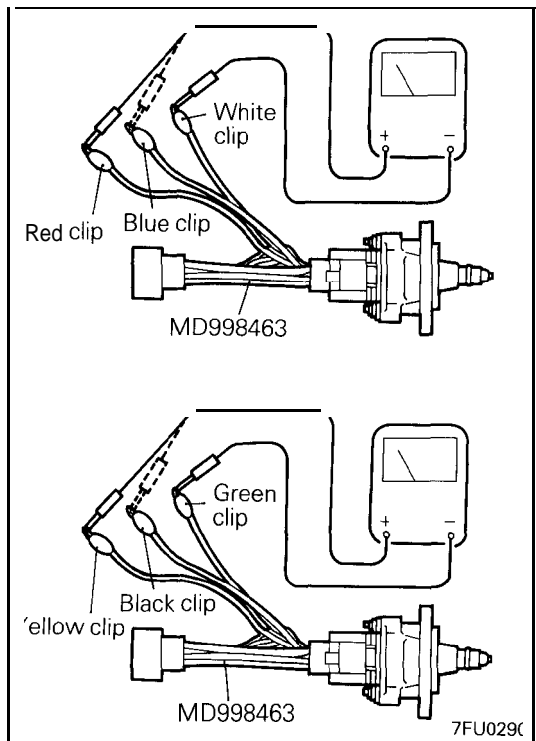

IDLE AIR CONTROL MOTOR

Checking the Coil Resistance

- (1) Connect Test Harness to the motor connector.
- (2) Measure the resistance between the white clip of Test Harness and the red clip or blue clip.

Standard value: 28 – 33 Ω at 20°C (68°F)

- (3) Measure the resistance between the green clip of Test Harness and the yellow clip or black clip.

Standard value: 28 – 33 Ω at 20°C (68°F)

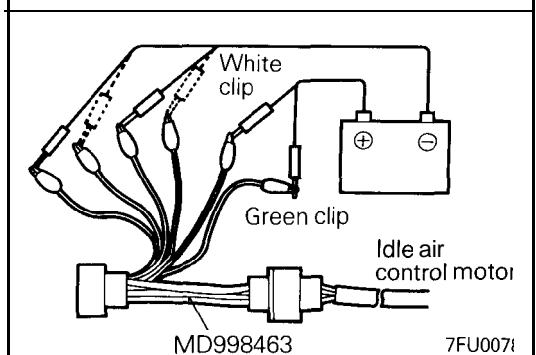

Operational Check

- (1) Connect Test Harness to the idle air control motor connector.
- (2) Connect the positive ⊕ terminal of 6 volt battery to the white clip and the green clip of Test Harness.

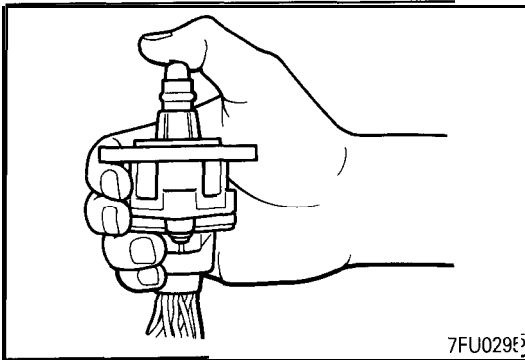

(3) Hold the idle air control motor as shown in the illustration, connect the negative \ominus terminal of the power supply to each clip as described in the following steps, and check whether or not a vibrating feeling (a feeling of very slight vibration of the stepper motor) is generated as a result of the activation of the stepper motor.

- ① Connect the negative \ominus terminal of the power supply to the red and black clip.
- ② Connect the negative \ominus terminal of the power supply to the blue and black clip.
- ③ Connect the negative \ominus terminal of the power supply to the blue and yellow clip.
- ④ Connect the negative \ominus terminal of the power supply to the red and yellow clip.
- ⑤ Connect the negative \ominus terminal of the power supply to the red and black clip.
- ⑥ Repeat the tests in sequence from ⑤ to ①.

(4) If, as a result of these tests, vibration is detected, the stepper motor can be considered to be normal.

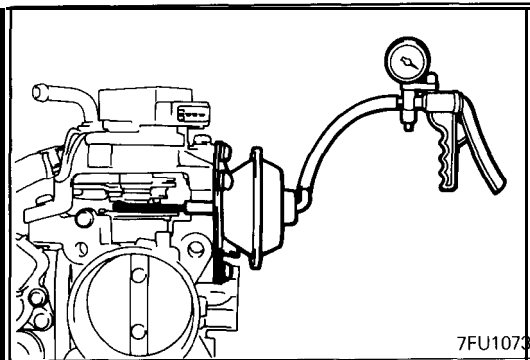

CHECKING VACUUM ACTUATOR – VEHICLES with TRACTION CONTROL

- (1) With the throttle valve opened, apply a vacuum of 200 mmHg (7.9 in.Hg.) to the vacuum actuator to make sure that the throttle valve closes.
- (2) Then lower the level of vacuum gradually to make sure that the vacuum actuator opens.

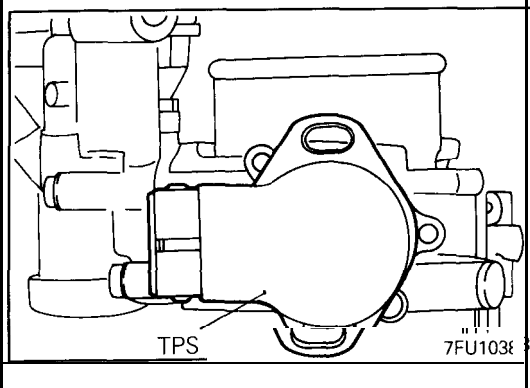

REASSEMBLY SERVICE POINTS

◆A◆ THROTTLE POSITION SENSOR (TPS) INSTALLATION – SOHC for DIAMANTE, DOHC

- (1) Install the throttle position sensor to the throttle body as shown in the illustration.

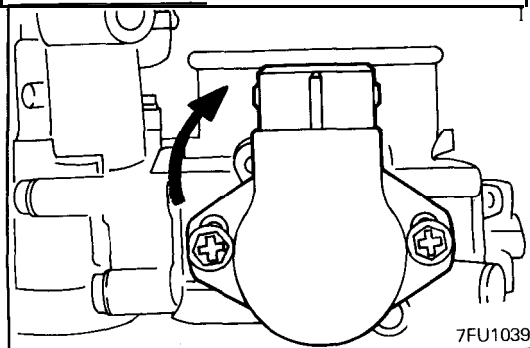

- (2) Turn the throttle position sensor 90° clockwise to set it, and tighten the screws.

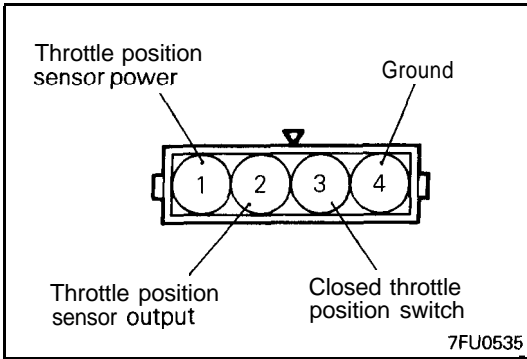

- (3) Connect a circuit tester between 4 (ground) and 2 (output), or between 2 (output) and 1 (power). Then, make sure that the resistance changes smoothly when the throttle valve is slowly moved to the fully open position.
- (4) Check for continuity across terminals 3 (closed throttle position switch) and 4 (ground) with the throttle valve both fully closed and fully open.

Throttle valve position	Continuity
Fully closed	Conductive
Fully open	Non-conductive

If there is no continuity with the throttle valve fully closed, turn TPS counterclockwise, and then check again.

NOTE

Some throttle position sensors are not provided with the position switch. In that case, the check described in step (4) cannot be accomplished.

- (5) If the above specifications are not met, replace TPS.

▶B▶ THROTTLE POSITION SENSOR (TPS) INSTALLATION

– SOHC for MONTERO and TRUCK

- (1) Install the throttle position sensor to the throttle body as shown in the illustration.

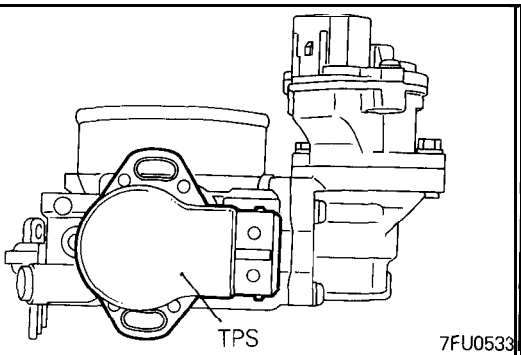

- (2) Turn the throttle position sensor 90° counterclockwise to set it, and tighten the screws.

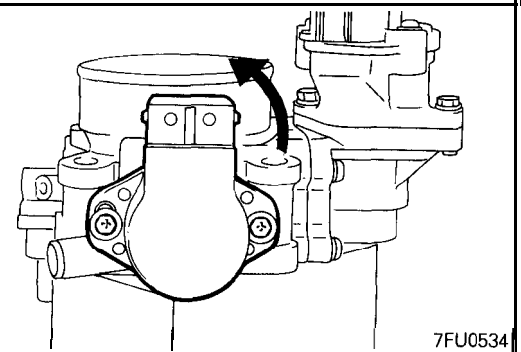

- (3) Connect a circuit tester between ① (ground) and ③ (output), or between ③ (output) and ④ (power). Then, make sure that the resistance changes smoothly when the throttle valve is slowly moved to the fully open position.
- (4) Check for continuity across terminals ② (closed throttle position switch) and ① (ground) with the throttle valve both fully closed and fully open.

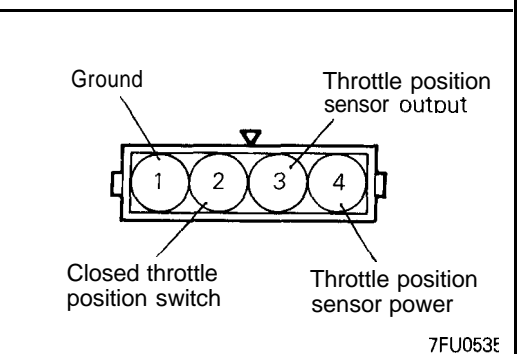

Throttle valve position	Continuity
Fully closed	Conductive
Fully open	Non-conductive

If there is no continuity with throttle valve fully closed, turn the throttle position sensor clockwise, and then check again.

- (5) If the above specifications are not met, replace TPS.

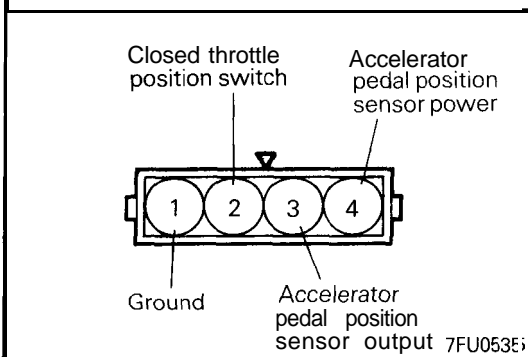
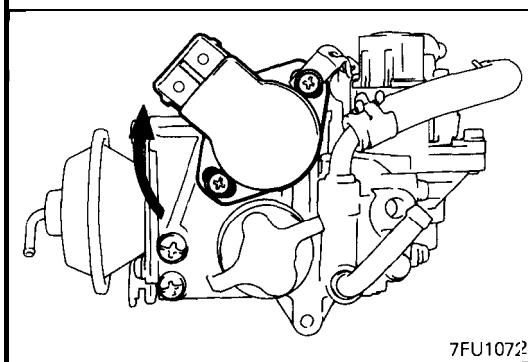
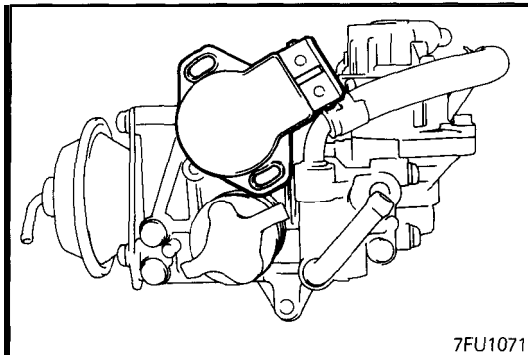

ACCELERATOR PEDAL POSITION SENSOR (APS) INSTALLATION

- (1) Install the accelerator pedal position sensor to the throttle body as shown in the illustration.

- (2) Turn the accelerator pedal position sensor 90° clockwise to set it, and tighten the screws.

- (3) Connect a circuit tester between (ground) and (output), or between (output) and (power). Then, make sure that the resistance changes smoothly when the throttle valve is slowly moved to the fully open position.

- (4) Check for continuity across terminals (closed throttle position switch) and (ground) with the throttle valve both fully closed and fully open.

Throttle valve position	Continuity
Fully closed	Conductive
Fully open	Non-conductive

If there is no continuity with the throttle valve fully closed, turn APS counterclockwise, and then check again.

- (5) If the above specifications are not met, replace APS.

IGNITION SYSTEM

SOHC for DIAMANTE

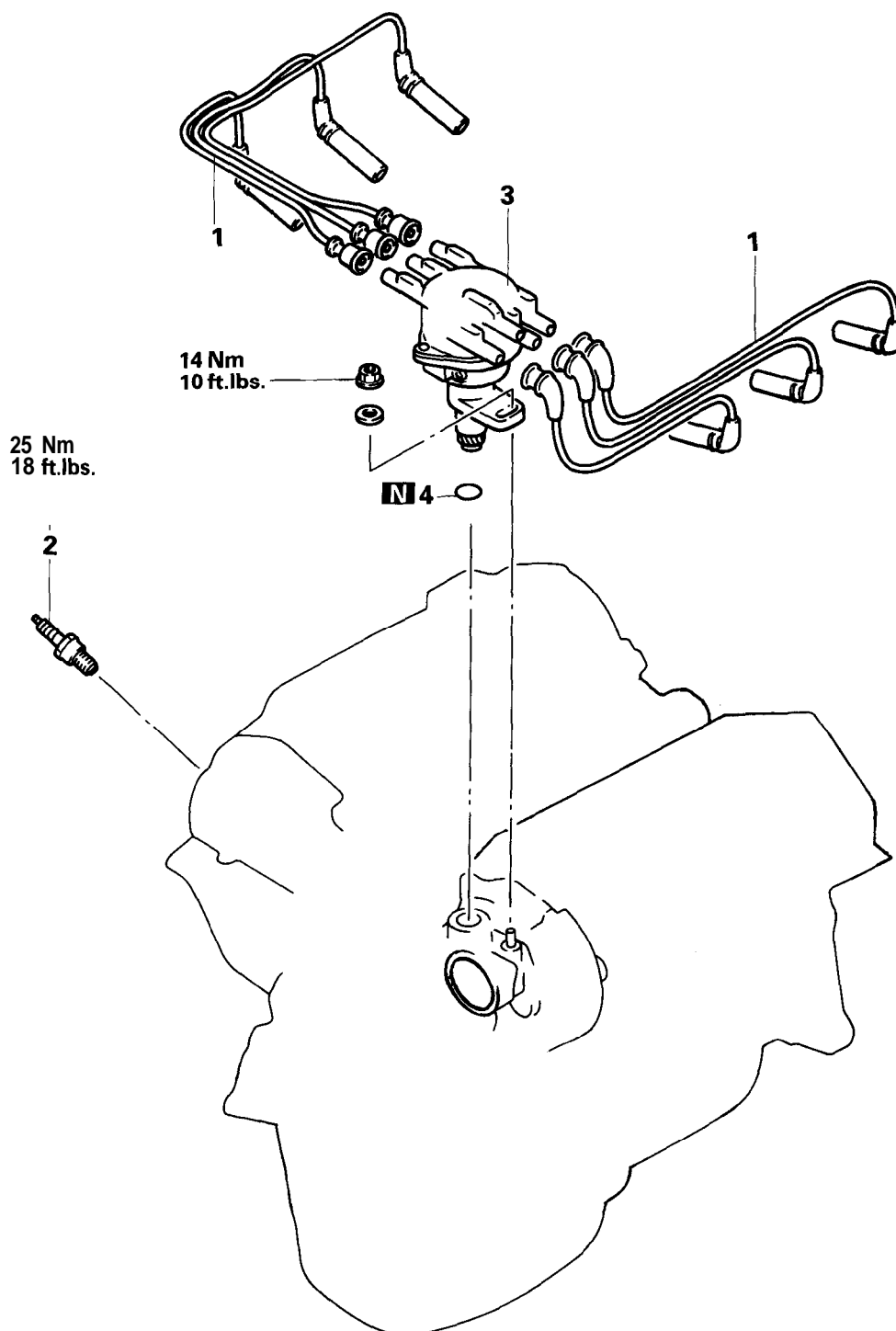

Removal steps

1. Spark plug cables
2. Spark plug
3. Distributor
4. O-ring

SOHC for MONTERO AND TRUCK

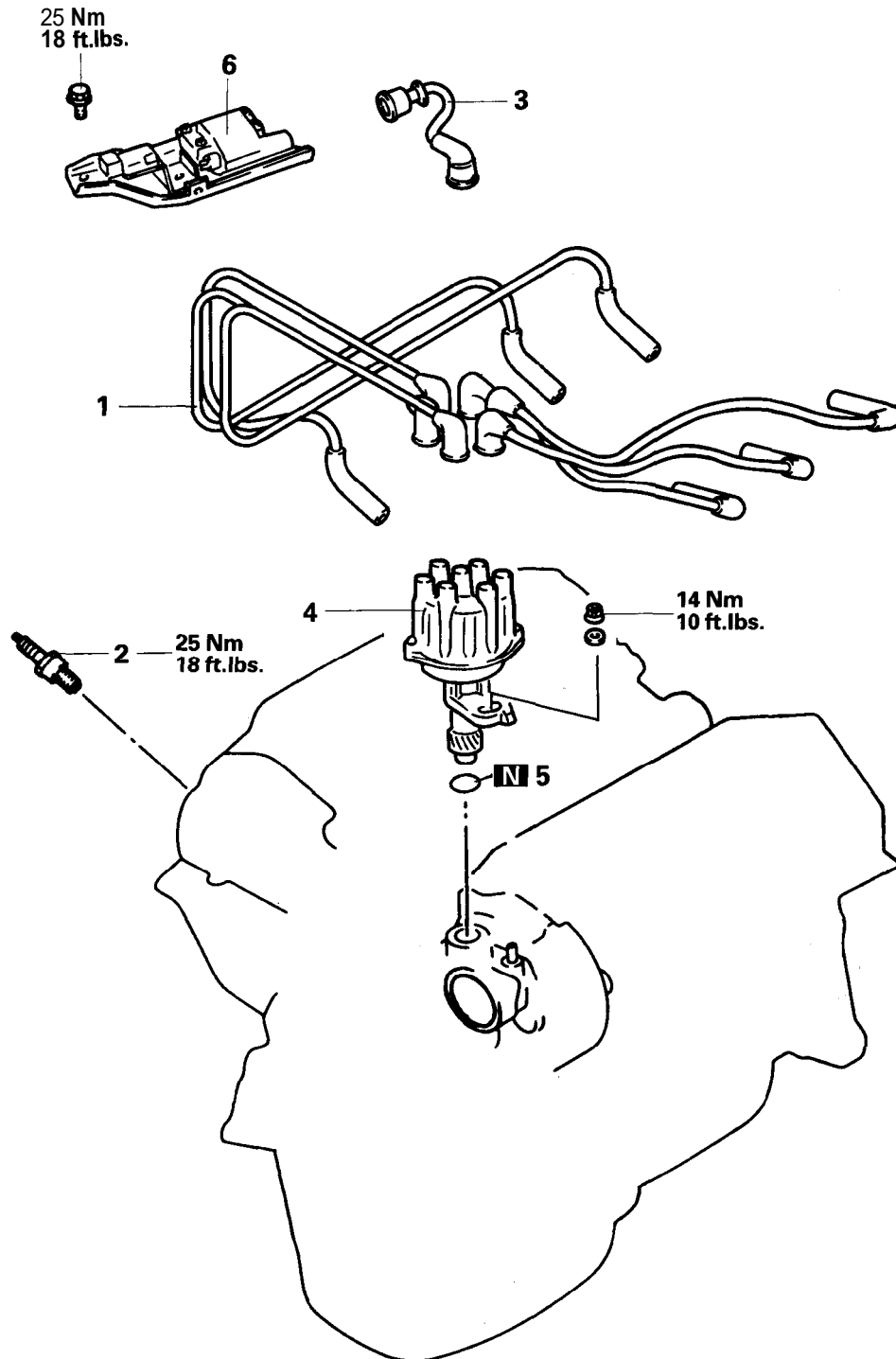

Removal steps

1. Spark plug cables
2. Spark plugs
3. High tension cable
- ◆▲ 4. Distributor
5. O-ring
6. Ignition coil

DOHC for DIAMANTE AND 3000GT

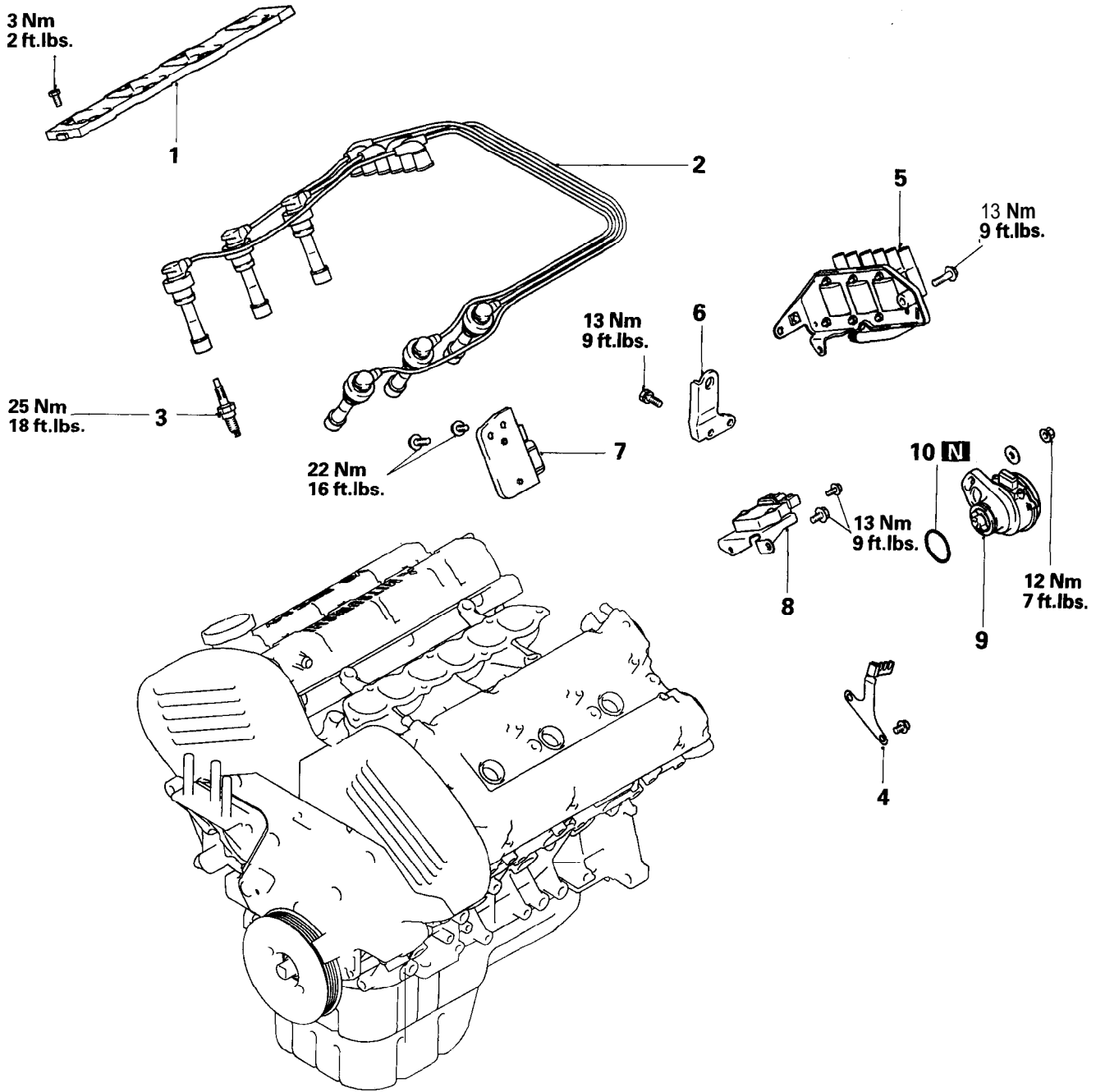

Removal steps

1. Center cover
2. Spark plug cables
3. Spark plugs
4. Clamp ————— From 1993 models
5. Ignition coil
6. Engine hanger
7. Ignition power transistor- DIAMANTE
8. Ignition power transistor — 3000GT
9. Crankshaft position sensor- Up to 1992 models
10. O-ring



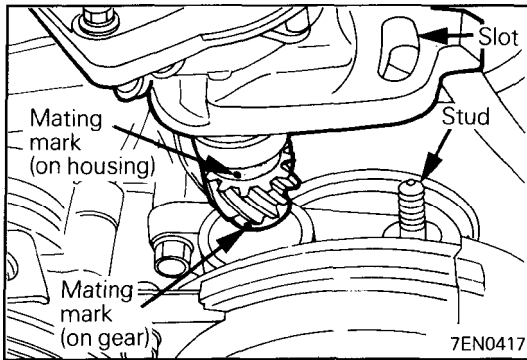

INSTALLATION SERVICE POINTS

▶A▶ DISTRIBUTOR INSTALLATION – SOHC

- (1) Turn the crankshaft so that the No. 1 cylinder is at compression top dead center.
- (2) Align the distributor housing and gear mating marks.
- (3) With the stud located in the center of the adjusting slot at the distributor, install the distributor.

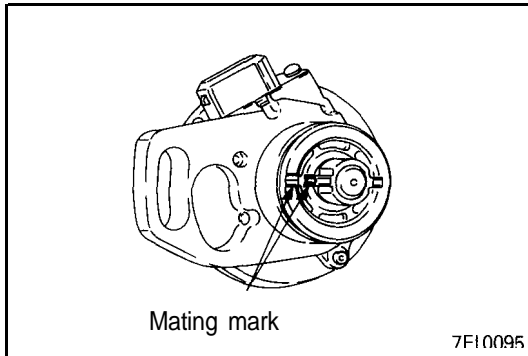

▶B▶ CRANKSHAFT POSITION SENSOR INSTALLATION – DOHC

- (1) Turn the crankshaft so that the No. 1 cylinder is at compression top dead center.
- (2) Install, lining up the matchmarks on the crankshaft position sensor housing and the coupling.

TIMING BELT – SOHC

REMOVAL AND INSTALLATION – DIAMANTE

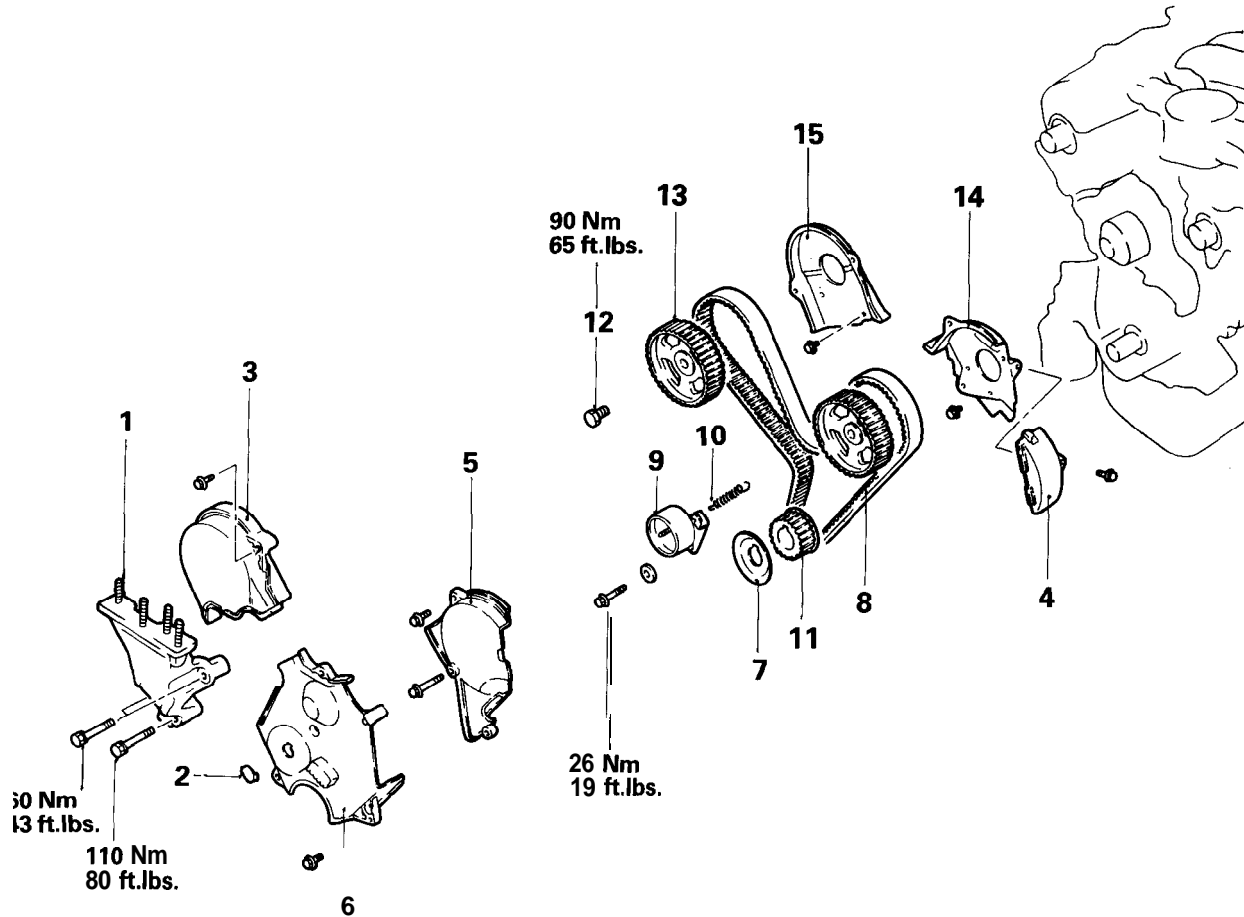

Removal steps

- ◆◆ 1. Engine support bracket
- 2. Access cover
- 3. Timing belt front upper cover, right
- 4. Timing belt cover cap
- 5. Timing belt front upper cover, left
- 6. Timing belt front lower cover
- 7. Flange
- ◁A▷ ◆C◆ 8. Timing belt
- ◆B◆ 9. Tensioner
- 10. Tensioner spring
- 11. Crankshaft sprocket
- ◁B▷ ◆A◆ 12. Camshaft sprocket bolt
- 13. Camshaft sprocket
- 14. Timing belt rear cover, left
- 15. Timing belt rear cover, right

REMOVAL AND INSTALLATION – MONTERO AND TRUCK

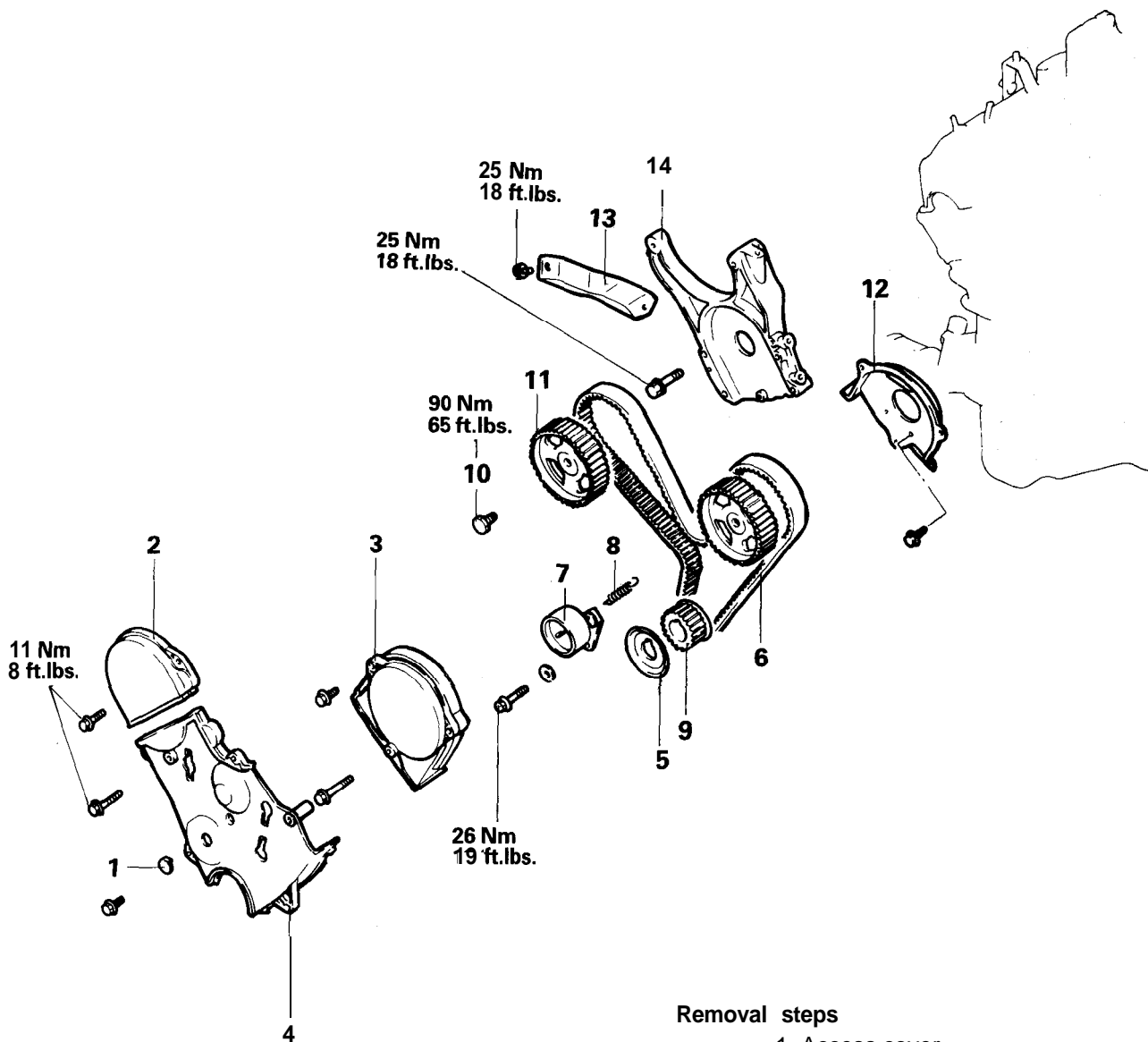

Removal steps

1. Access cover
2. Timing belt front upper cover, right
3. Timing belt front upper cover, left
4. Timing belt front lower cover
5. Flange
- ◀A▶▶C▶▶B▶▶ 6. Timing belt
- ▶B▶▶A▶▶ 7. Tensioner
8. Tensioner spring
9. Crankshaft sprocket
- ◀B▶▶A▶▶ 10. Camshaft sprocket bolt
11. Camshaft sprocket
12. Timing belt rear upper cover, left
13. Generator stay
14. Generator bracket

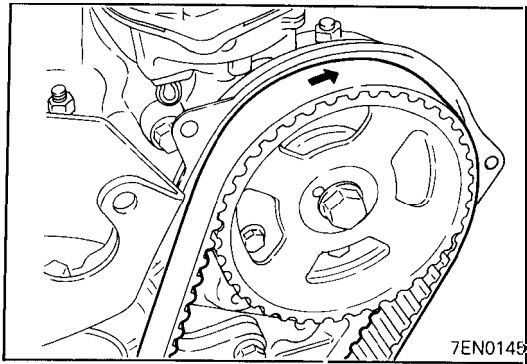

REMOVAL SERVICE POINTS

◁A▷ TIMING BELT REMOVAL

- (1) Mark the belt running direction for reference in reinstallation.

NOTE

- (1) Water or oil on the belt shortens its life drastically, so the removed timing belt, sprocket, and tensioner must be kept free from oil and water. Do not immerse parts in cleaning solvent.
- (2) If there is oil or water on any part, check the front case oil seal, camshaft oil seal and water pump for leaks.

◁B▷ CAMSHAFT SPROCKET BOLT REMOVAL

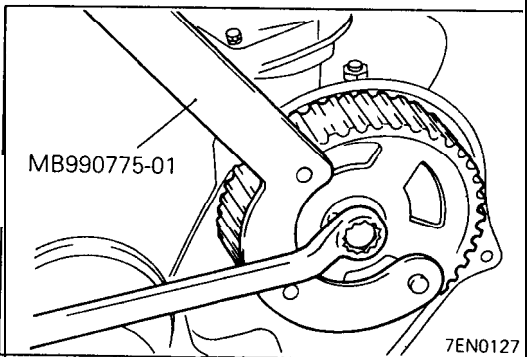

INSPECTION

TIMING BELT

Replace belt if any of the following conditions exist.

- (1) Hardening of back rubber-back side is glossy without resilience and leaves no indent when pressed with fingernail.

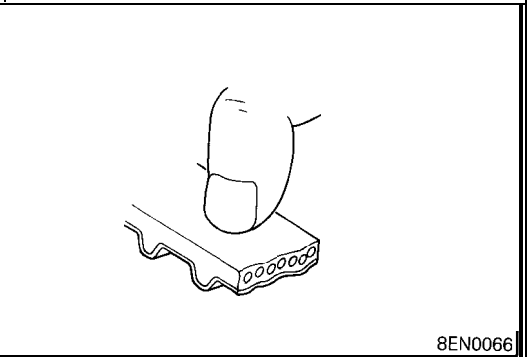

- (2) Cracks on rubber back
- (3) Cracks or peeling of canvas
- (4) Cracks on tooth bottom
- (5) Cracks on belt

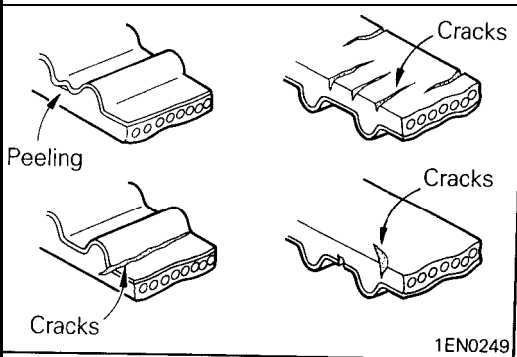

- (6) Abnormal wear of belt sides. The sides are normal if they are sharp as if cut by a knife.

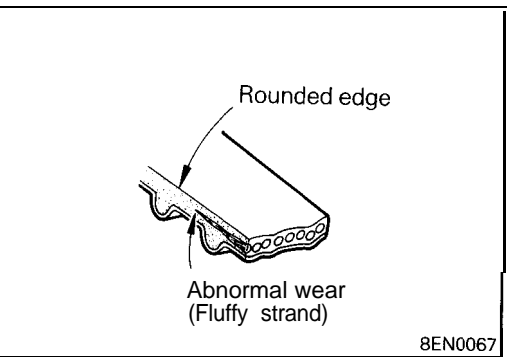

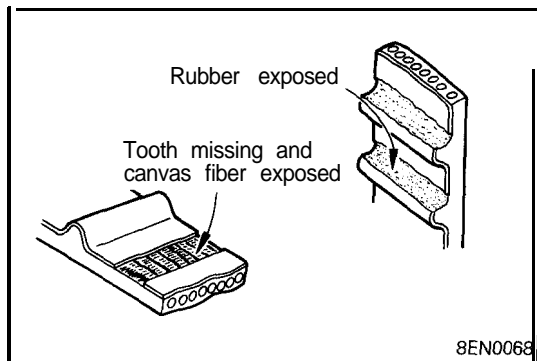

- (7) Abnormal wear on teeth
- (8) Tooth missing and canvas fiber exposed.

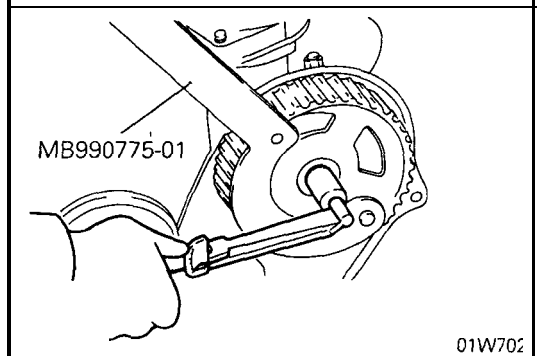

INSTALLATION SERVICE POINTS

◆A◆ CAMSHAFT SPROCKET BOLT INSTALLATION

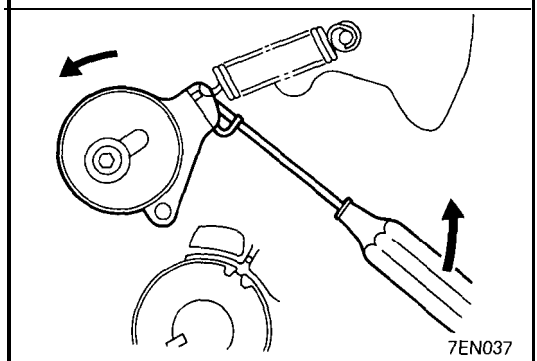

◆B◆ TIMING BELT TENSIONER INSTALLATION

- (1) Insert a screwdriver into the hole of the timing belt tensioner arm, move it all the way in the direction of the arrow, and tighten the tensioner lock bolt to temporarily hold this position.

⚡ TIMING BELT INSTALLATION

- (1) Align the timing marks of the camshaft sprockets and the crankshaft sprocket.
- (2) Install the timing belt on the crankshaft sprocket first and while keeping the belt tight on the tension side, install the belt on the left camshaft sprocket.
- (3) Then, install on the water pump pulley and on the right camshaft sprocket and finally on the timing belt tensioner.

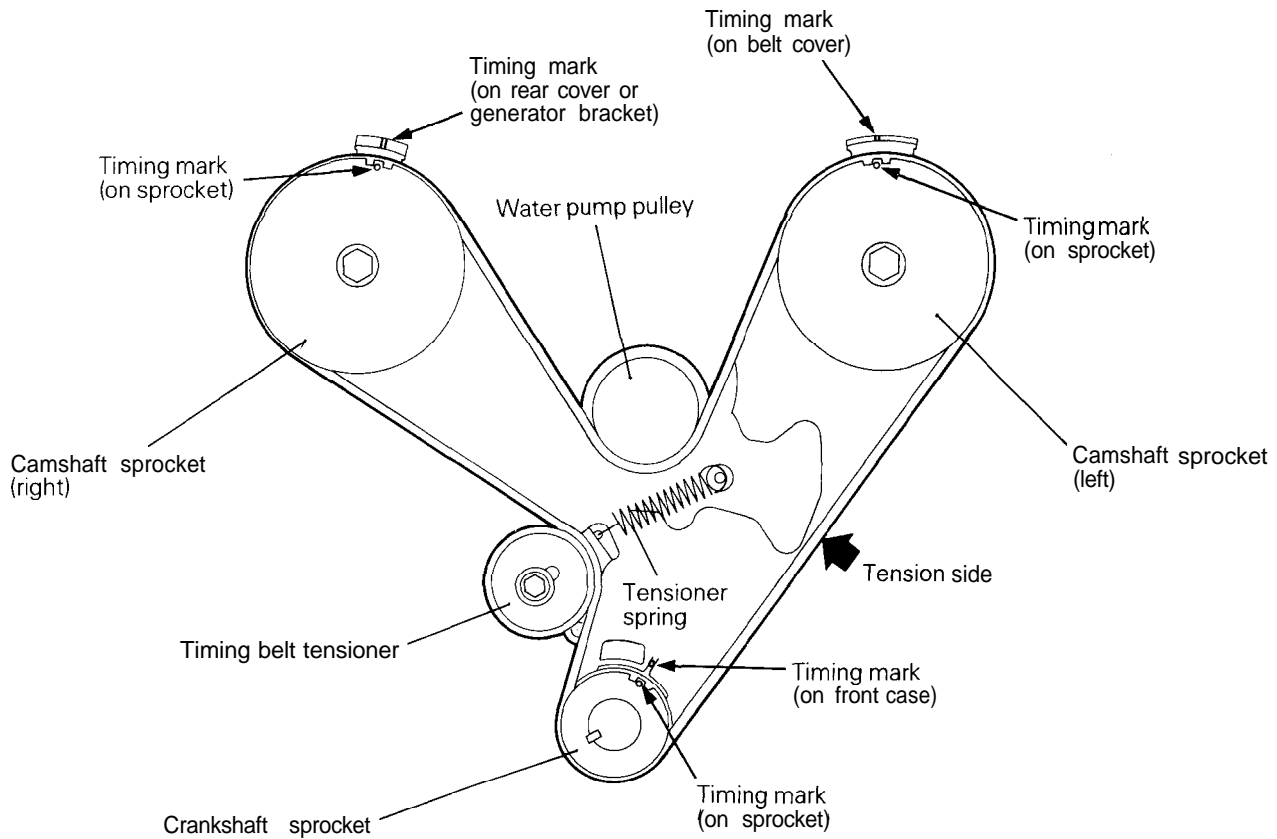

7EN0007

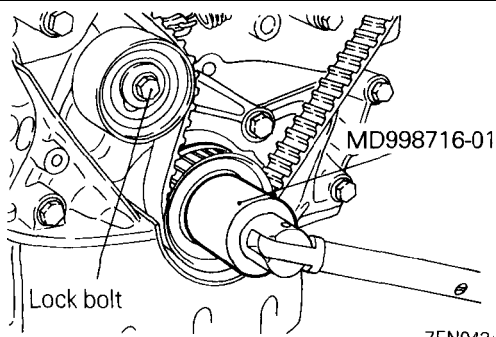

- (4) Install the flange onto the front end of the crankshaft.
- (5) Install the special tool onto the crankshaft.
- (6) Loosen the tensioner lock bolt one or two turns and allow the spring to tension the timing belt.
- (7) Turn the crankshaft two full turns clockwise. Turn smoothly and in clockwise direction only.
- (8) Again line up the timing marks on the sprockets and tighten the tensioner lock bolt to the specified torque.

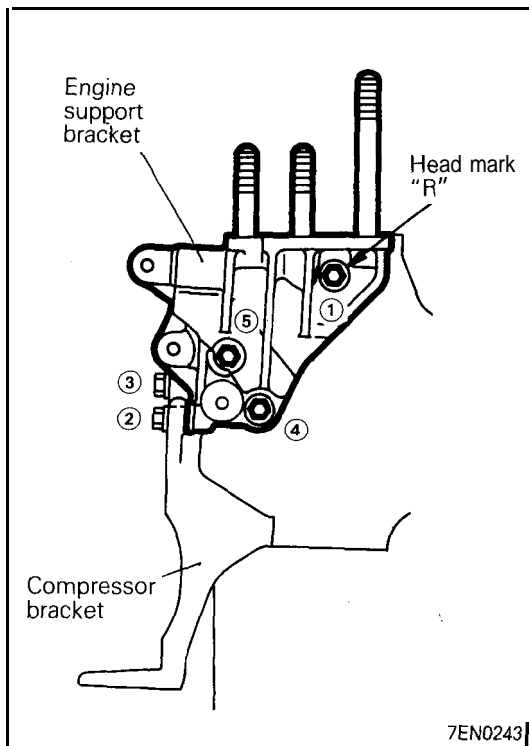

ENGINE SUPPORT BRACKET INSTALLATION – DIAMANTE

- (1) Tighten the engine support bracket bolts in the order shown in the illustration.

NOTE

The bolt used at the location shown in the illustration is a reamer bolt (head mark "R").

TIMING BELT – DOHC

REMOVAL AND INSTALLATION – Up to 1992 models

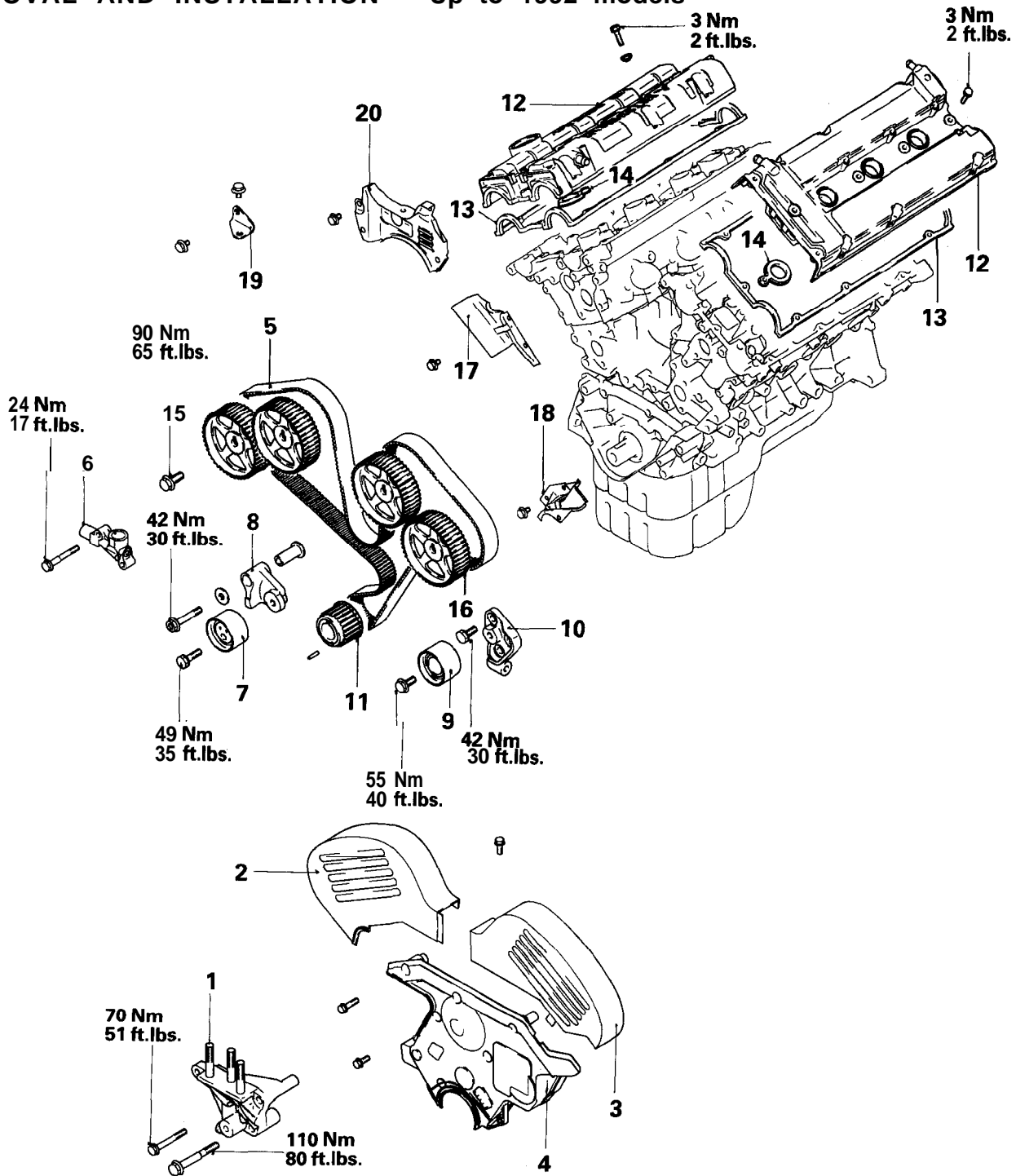

Removal steps

- | | |
|--|--|
| <ul style="list-style-type: none"> ◆E◆ 1. Engine support bracket 2. Timing belt front upper cover, right 3. Timing belt front upper cover, left 4. Timing belt front lower cover ◇A◇ ◆D◆ 5. Timing belt ◆C◆ 6. Auto tensioner 7. Tensioner pulley 8. Tensioner arm assembly 9. Idler pulley 10. Idler pulley bracket | <ul style="list-style-type: none"> 11. Crankshaft sprocket ◆B◆ 12. Rocker cover 13. Rocker cover gasket, A 14. Rocker cover gasket, B ◇B◇ ◆A◆ 15. Camshaft sprocket bolt 16. Camshaft sprocket 17. Timing belt rear cover, right 18. Timing belt rear cover, left 19. Bracket 20. Timing belt rear cover, center |
|--|--|

REMOVAL AND INSTALLATION – From 1993 models

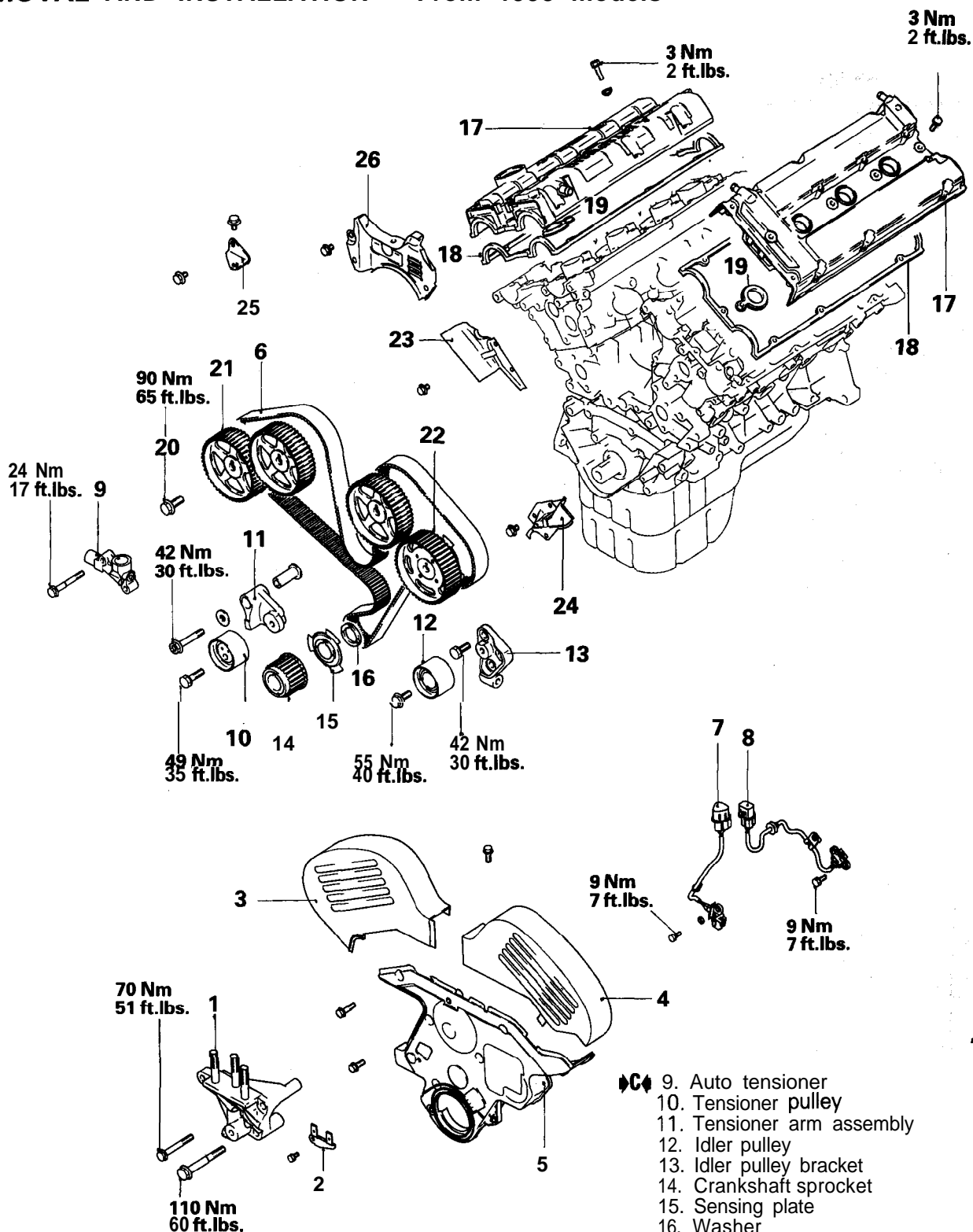

Removal steps

- ▶E◀ 1. Engine support bracket
- 2. Crankshaft position sensor bracket
- 3. Timing belt front upper cover, right
- 4. Timing belt front upper cover, left
- 5. Timing belt front lower cover
- ◀A▶ ▶D▶ 6. Timing belt
- 7. Crankshaft position sensor
- 8. Camshaft position sensor

- ▶C▶ 9. Auto tensioner
- 10. Tensioner pulley
- 11. Tensioner arm assembly
- 12. Idler pulley
- 13. Idler pulley bracket
- 14. Crankshaft sprocket
- 15. Sensing plate
- 16. Washer
- ▶B▶ 17. Rocker cover
- 18. Rocker cover gasket, A
- 19. Rocker cover gasket, B
- ◀B▶ ▶A▶ 20. Camshaft sprocket bolt
- 21. Camshaft sprocket
- 22. Camshaft sprocket
- 23. Timing belt rear cover, right
- 24. Timing belt rear cover, left
- 25. Bracket
- 26. Timing belt rear cover, center

7EN0498

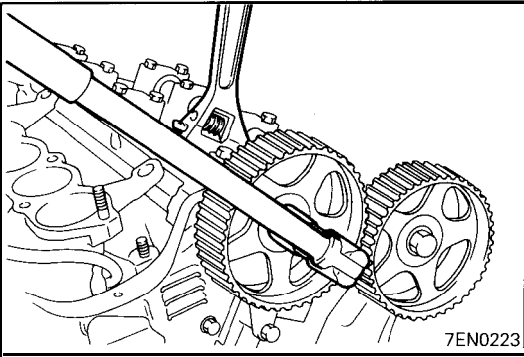
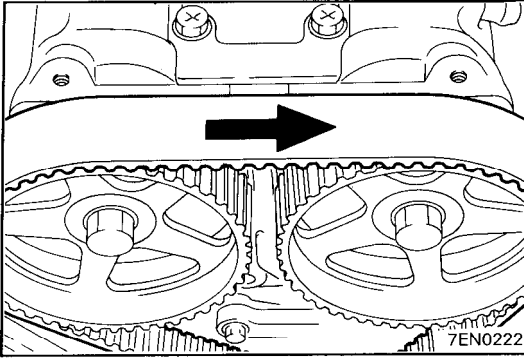

REMOVAL SERVICE POINTS

◊A◊ TIMING BELT REMOVAL

- (1) Mark the belt running direction for reference in reinstallation.

NOTE

- (1) Water or oil on the belt shortens its life drastically, so the removed timing belt, sprocket, and tensioner must be kept free from oil and water. Do not immerse parts in cleaning solvent.
- (2) If there is oil or water on any part, check the front case oil seal, camshaft oil seal and water pump for leaks.

◊B◊ CAMSHAFT SPROCKET BOLT REMOVAL

- (1) Hold the hexagonal portion of the camshaft with a wrench, when removing the camshaft sprocket bolt.

INSPECTION

TIMING BELT

Refer to "INSPECTION" on page 11E-50.

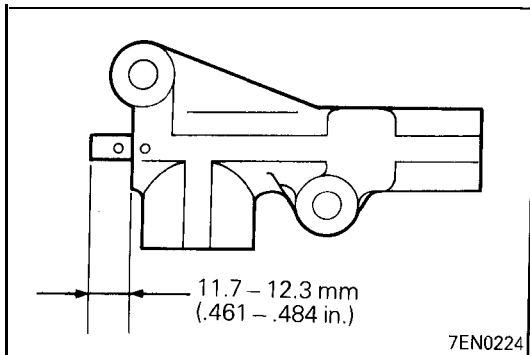

AUTO-TENSIONER

- (1) Check for oil leaks. If oil leaks are evident, replace the auto-tensioner.
- (2) Check the rod end for wear or damage and replace the auto-tensioner if necessary.
- (3) Measure the rod projection length. If the reading is outside the standard value, replace the auto tensioner.

Standard value: 11.7 – 12.3 mm (.461 – .484 in.)

- (4) Use a vice to force the auto tensioner rod in. If the rod slides in easily, replace the tensioner. If there is nothing wrong, the rod will offer considerable resistance.

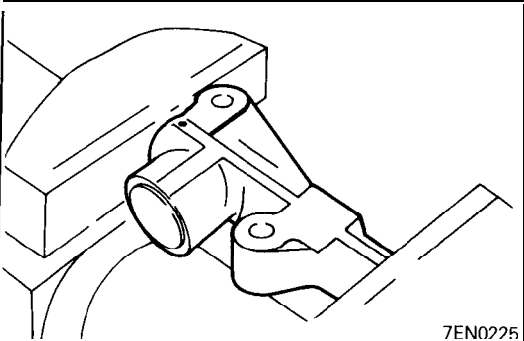

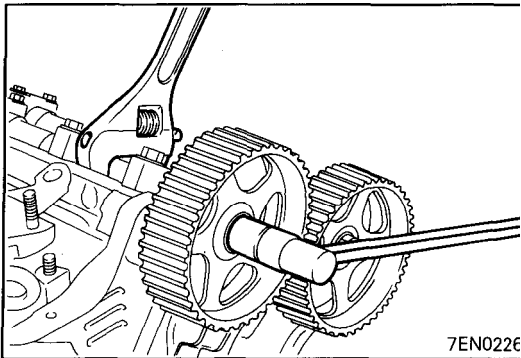
**INSTALLATION SERVICE POINTS****▶▶ CAMSHAFT SPROCKET BOLT TIGHTENING**

- (1) Hold the hexagonal portion of the camshaft with a wrench when tightening the camshaft sprocket bolt. Tighten the bolt to the specified torque.

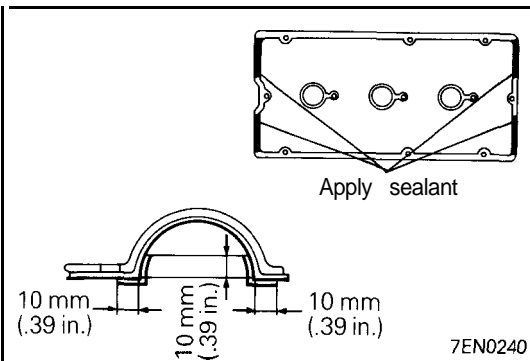
**▶▶ ROCKER COVER INSTALLATION**

- (1) Apply sealant to the areas shown in the illustration.
Specified sealant: 3M ATD Part No.8660 or equivalent.

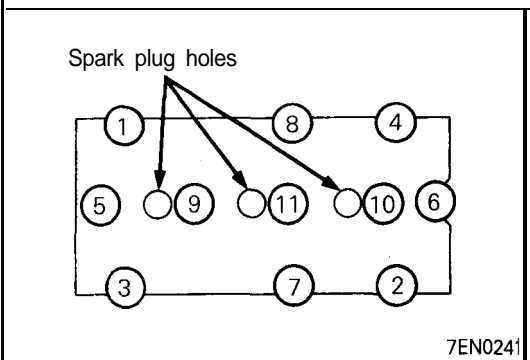

- (2) Tighten the rocker cover bolts in the sequence shown in the illustration.

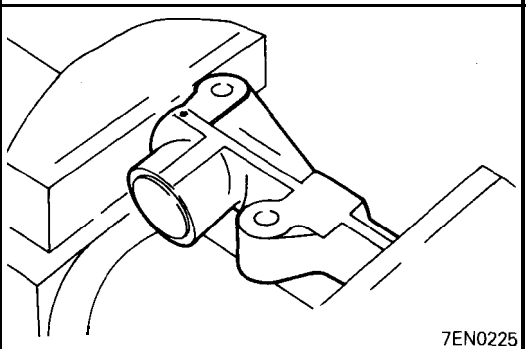
**▶▶ AUTO-TENSIONER INSTALLATION**

If the auto-tensioner rod is fully extended, set it in the retracted position with the following procedure.

- (1) Set the auto tensioner in a vice.

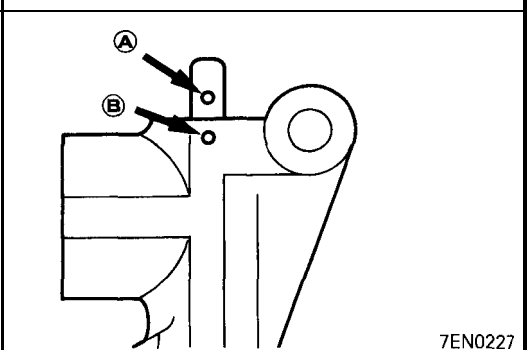

- (2) Slowly close the vice to force the rod in until the set hole (A) of the rod is lined up with the set hole (B) of the cylinder.
- (3) Insert a wire [1.4 mm (.055 in.) in diameter] into the set holes.
- (4) Remove the auto tensioner from the vice.
- (5) On engines with turbocharger, apply sealant to the threads of the auto tensioner mounting bolt.

Specified sealant: 3M ATD Part No.8660 or equivalent.

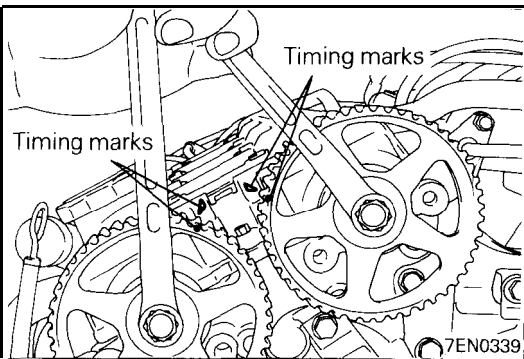
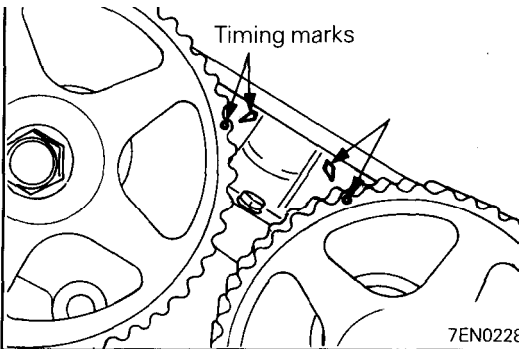
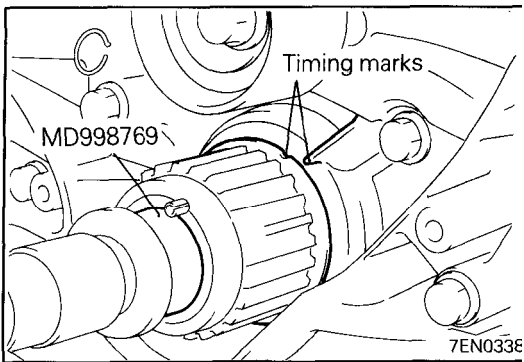

⚡ TIMING BELT INSTALLATION

- (1) Using the special tool, line up the crankshaft sprocket timing marks, and then rotate the sprocket one tooth counterclockwise.

- (2) Line up the timing marks of the camshaft sprockets for left bank.

- (3) Using two wrenches, line up the timing marks of the camshaft sprockets for right bank.

Caution

1. Since valve spring force can turn the camshaft sprocket, be careful not to catch your finger.
2. If either camshaft sprocket is rotated one complete turn clockwise or counterclockwise after lining up the timing marks of the other camshaft sprocket, the intake and exhaust valves might interfere. Consequently, if a camshaft sprocket was turned too far in lining up the timing marks, be sure to rotate it back from that position to line up again the timing marks.

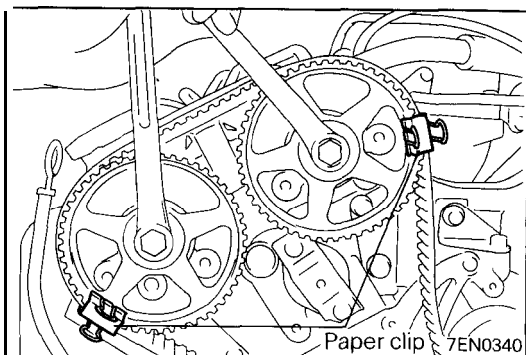

- (4) Install the timing belt on the exhaust side camshaft sprocket for right bank and hold it with a paper clip at the position shown in the illustration.
- (5) Install the timing belt on the intake side camshaft sprocket and hold it with a paper clip at the positions shown in the illustration.

Caution

Since the camshaft sprocket turns easily, avoid excessive pulling on the timing belt.

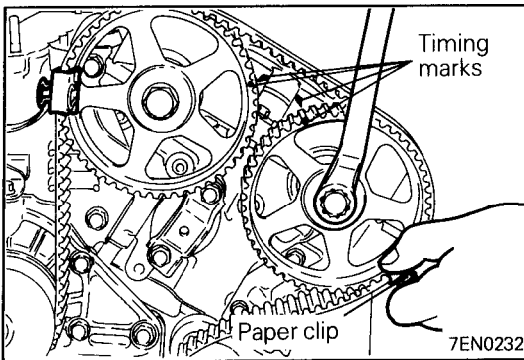

- (6) Check that the timing marks of the camshaft sprockets for left bank are in alignment. Then install the timing belt on these sprockets and hold it with a paper clip at the positions shown in the illustration.
- (7) Install the timing belt on the idler pulley.
- (8) Install the timing belt on the crankshaft sprocket.
- (9) Install the timing belt on the tensioner pulley.

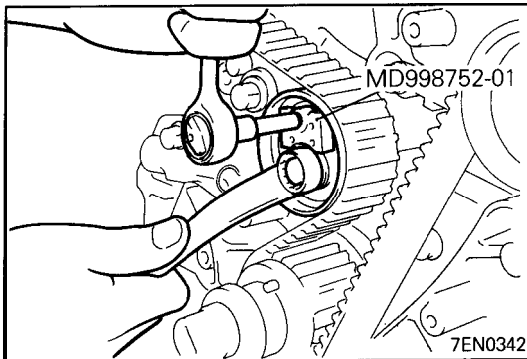

- (10) Using the special tool, rotate the tensioner pulley clockwise to tighten the center bolt.
- (11) Remove the four paper clips.

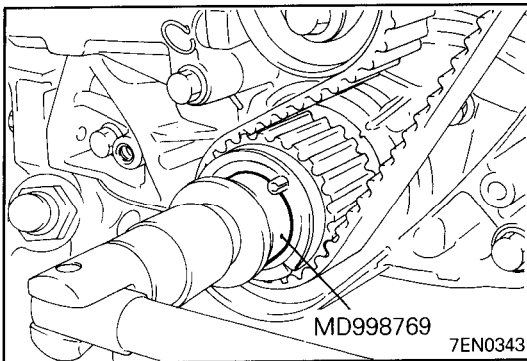

- (12) Using the special tool, turn the crankshaft a quarter turn counterclockwise. Then rotate it clockwise to line up the timing marks and check that all the timing marks are in alignment.

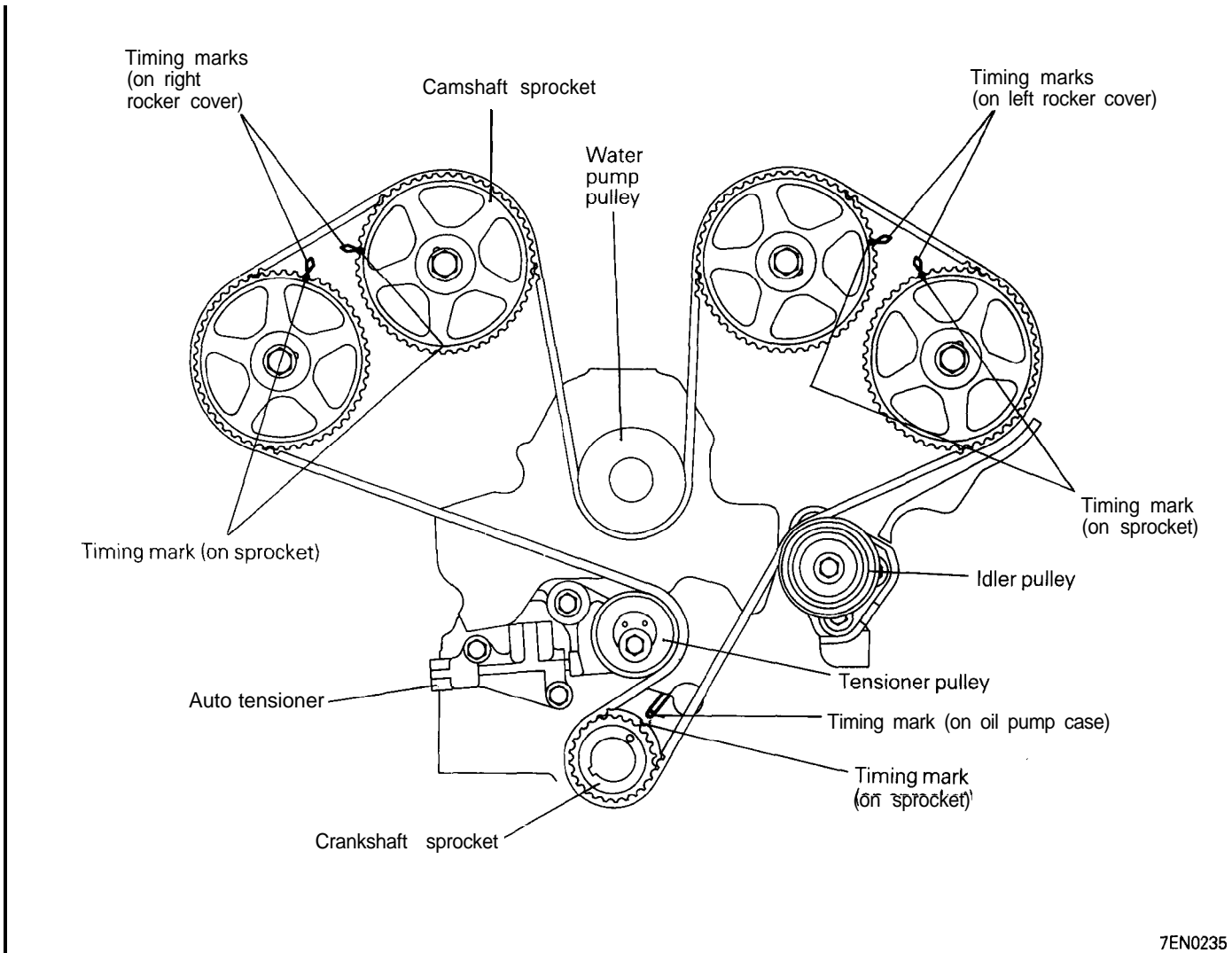

7EN0235

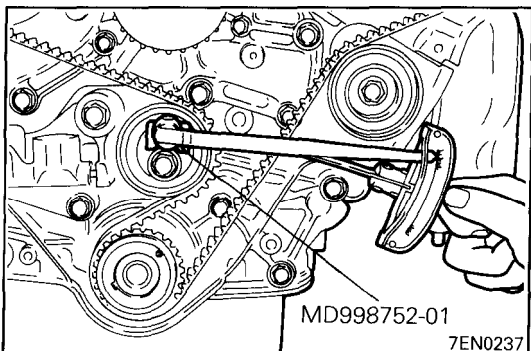

- (13) Loosen the center bolt of the auto-tensioner pulley, and install the special tool and a torque wrench on the pulley. While holding the pulley with approximately 10 Nm (7 ft.lbs.) torque to prevent it from turning, tighten the center bolt to the specified torque.

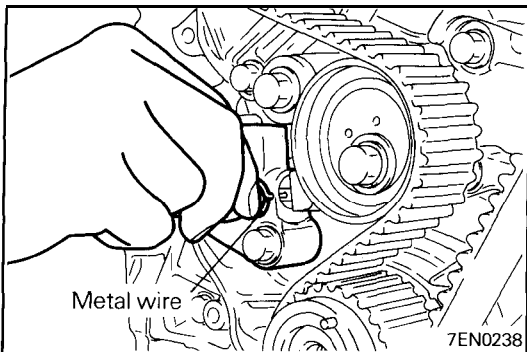

- (14) Turn the crankshaft two turns clockwise, and leave it alone for about five minutes. Then move in and out the auto-tensioner setting metal wire to check that the wire moves smoothly.

NOTE

If the metal wire does not move smoothly, repeat step (12) until it does move smoothly.

- (15) Remove the auto tensioner setting metal wire.

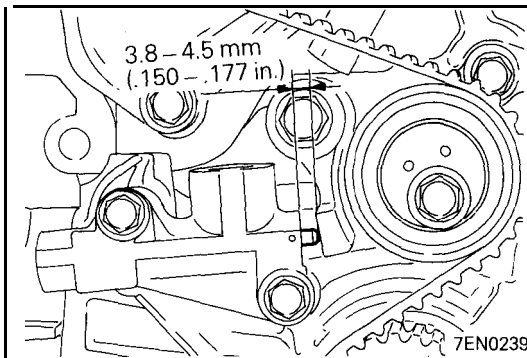

(16) Check that the spacing between the tensioner arm and auto tensioner is within the standard limit.

Standard value: 3.8 – 4.5 mm (.150 – .177 in.)

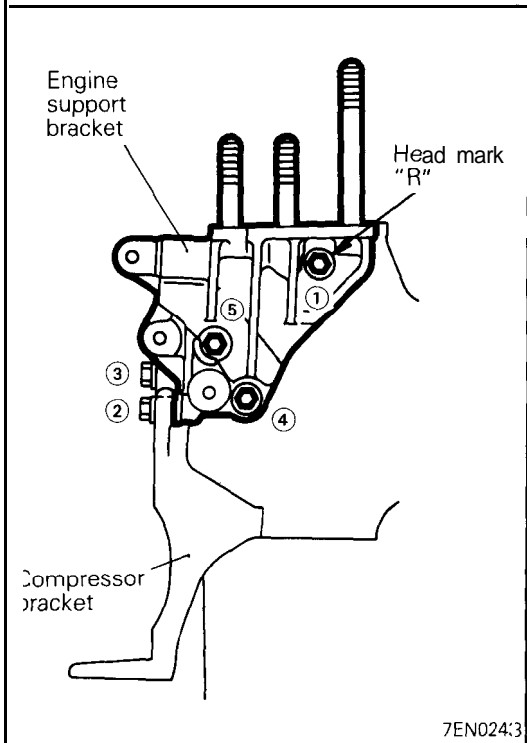

ENGINE SUPPORT BRACKET INSTALLATION

(1) Tighten the engine support bracket bolts in the order shown in the illustration.

NOTE

The bolt used at the location shown in the illustration is a reamer bolt (head mark "R").

INTAKE MANIFOLD AND FUEL PARTS

REMOVAL AND INSTALLATION – SOHC for DIAMANTE

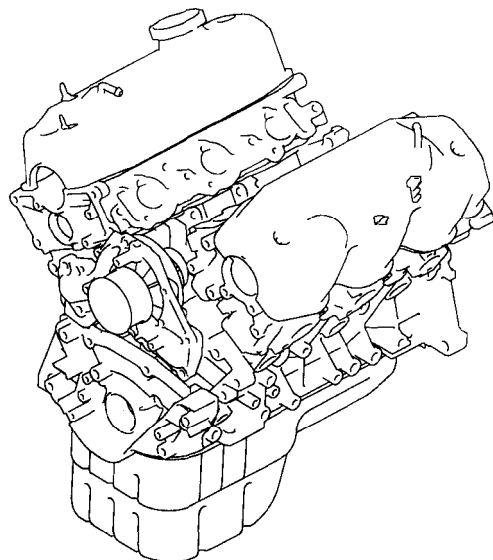
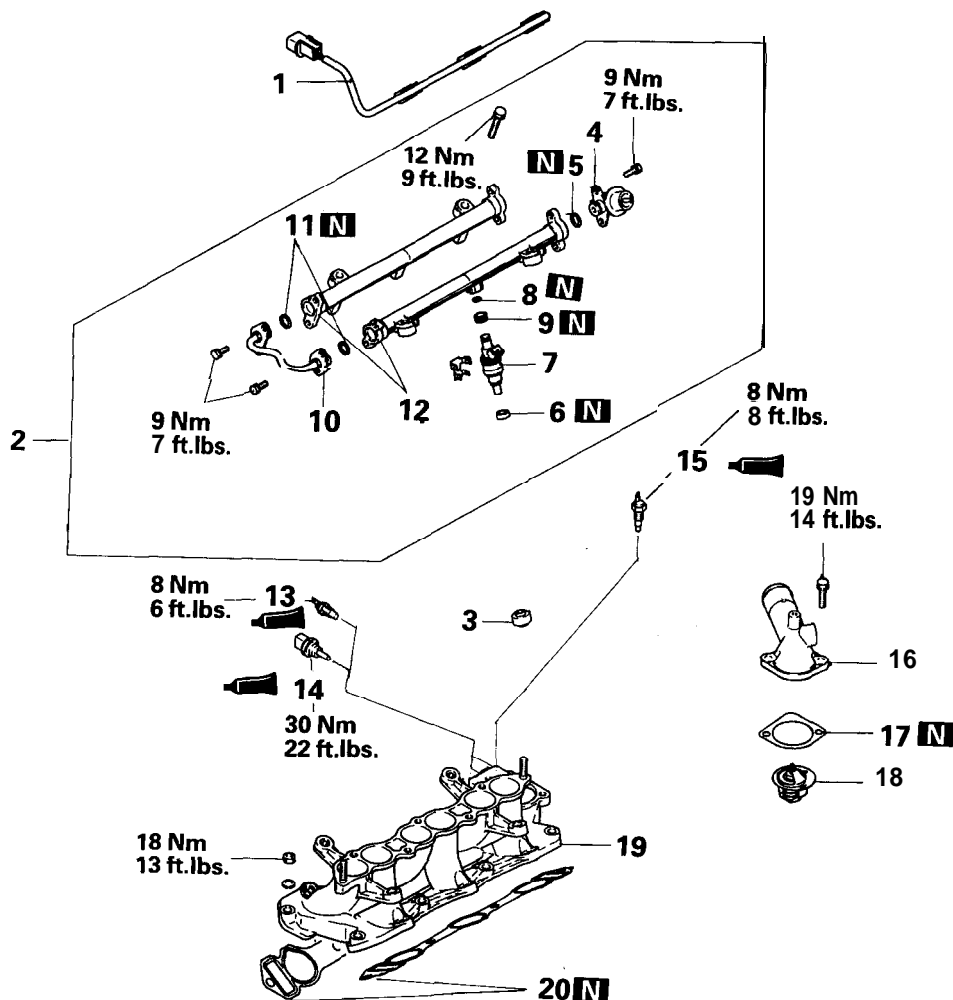

Removal steps

1. Injector harness
2. Injector and fuel rail
3. Insulator
- ◆G◆ 4. Fuel pressure regulator
5. O-ring
6. Insulator
- ◆F◆ 7. Injectors
8. O-ring
9. Gromet
10. Fuel pipe
11. O-ring
12. Fuel rail
- ◆D◆ 13. Engine coolant temperature gauge unit
- ◆C◆ 14. Engine coolant temperature sensor
- ◆B◆ 15. Thermo switch
16. Water outlet fitting
17. Water outlet fitting gasket
18. Thermostat
19. Intake manifold
20. Intake manifold gasket

7EN0499

REMOVAL AND INSTALLATION – SOHC for MONTERO AND TRUCK

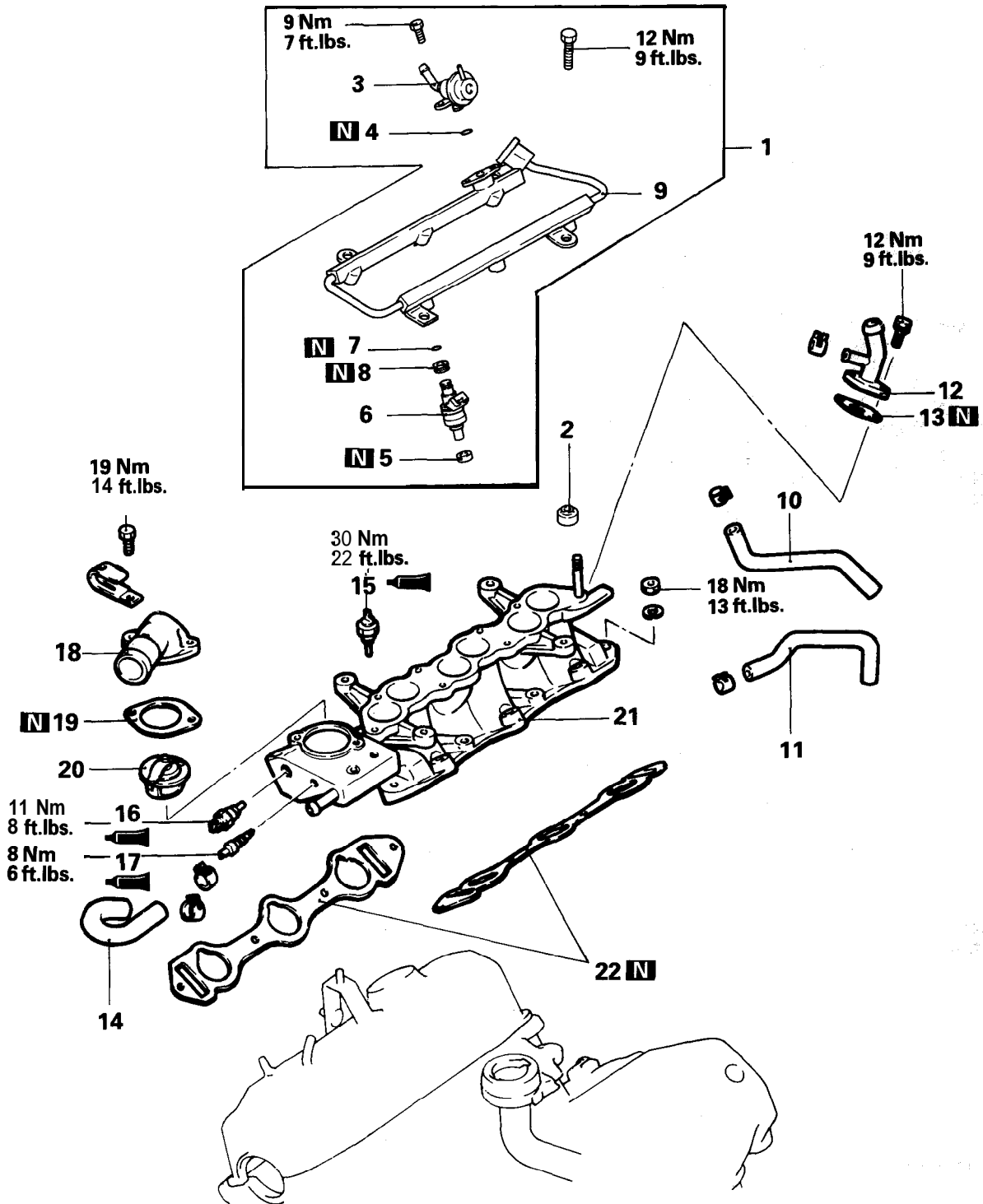

Removal steps

- | | |
|---------------------------------------|--|
| 1. Injector and fuel rail | 12. Heat pipe |
| 2. Insulator | 13. Heat pipe gasket |
| ◆G◆ 3. Fuel pressure regulator | 14. Water hose |
| 4. O-ring | ◆D◆ 15. Engine coolant temperature gauge unit |
| 5. Insulator | ◆C◆ 16. Engine coolant temperature sensor |
| ◆F◆ 6. Injectors | ◆B◆ 17. Thermo switch |
| 7. O-ring | 18. Water outlet fitting |
| 8. Gromet | 19. Water outlet fitting gasket |
| 9. Fuel rail | 20. Thermostat |
| 10. Water hose A | 21. Intake manifold |
| 11. Water hose B | 22. Intake manifold gasket |

REMOVAL AND INSTALLATION – DOHC

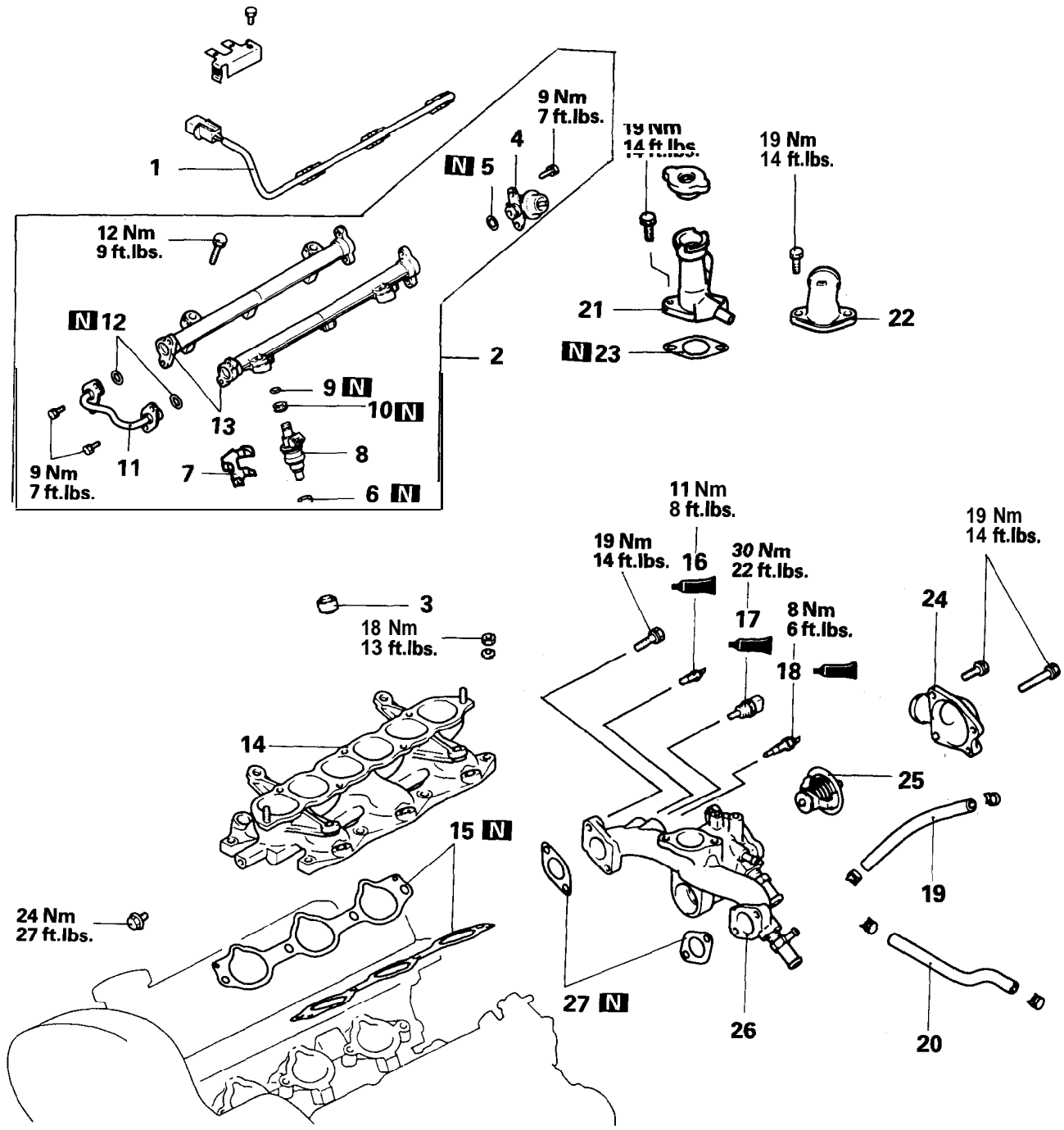

Removal steps

- 1. Injector harness
- 2. Injector and fuel rail
- 3. Insulator
- ◆G◆ 4. Fuel pressure regulator
- 5. O-ring
- 6. Insulator
- 7. Injector clip
- ◆F◆ 8. Injectors
- 9. O-ring
- 10. Gromet
- 11. Fuel pipe
- 12. O-ring
- 13. Fuel rail
- ◆E◆ 14. Intake manifold
- 15. Intake manifold gasket
- ◆D◆ 16. Engine coolant temperature gauge unit
- ◆C◆ 17. Engine coolant temperature sensor
- ◆B◆ 18. Thermo switch
- 19. Water hose
- 20. Water hose A
- 21. Water outlet fitting — 3000GT
- 22. Water outlet fitting — DIAMANTE
- 23. Water outlet fitting gasket
- 24. Water inlet fitting
- ◆A◆ 25. Thermostat
- 26. Thermostat housing
- 27. Thermostat housing gasket

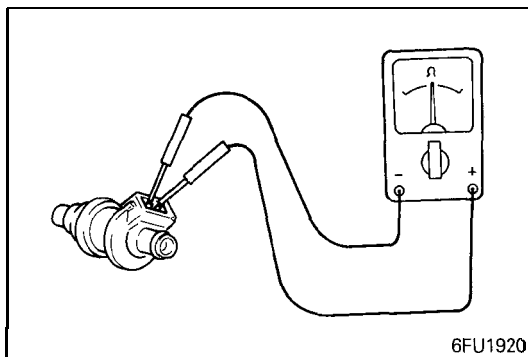
**INSPECTION****INJECTORS**

- (1) Measure the resistance between the terminals of the injectors using a circuit tester. If the resistance is out of the specification, replace the injector.

Standard value:

Non Turbo 13 – 16 Ω at 20°C (68°F)

Turbo 2 – 3 Ω at 20°C (68°F)

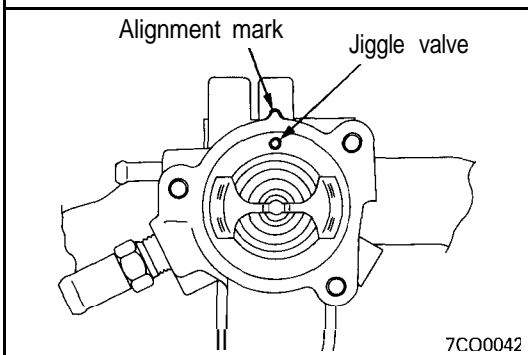
**INSTALLATION SERVICE POINTS****▶▶ THERMOSTAT INSTALLATION – DOHC**

- (1) install the thermostat and line up the jiggle valve with the alignment mark on the thermostat housing.

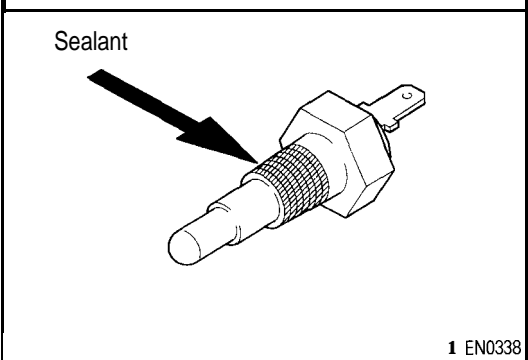
**▶▶****SEALANT APPLICATION TO THERMO SWITCH**

Specified sealant: **3M** Part No. 8660 or equivalent

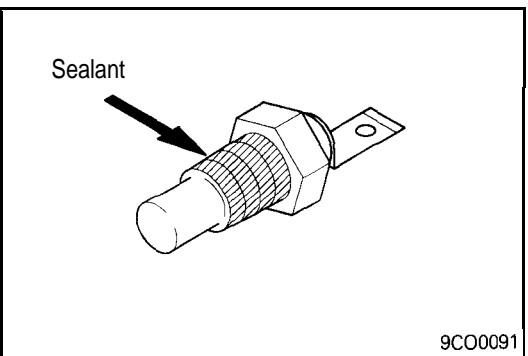
**▶▶****SEALANT APPLICATION TO ENGINE COOLANT TEMPERATURE SENSOR**

Specified sealant:

3M Nut Locking No. 4171 or equivalent

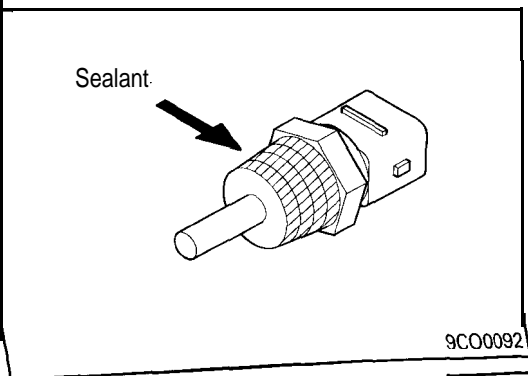
**▶▶****SEALANT APPLICATION TO ENGINE COOLANT TEMPERATURE GAUGE UNIT**

Specified sealant: **3M** Part No. 8660 or equivalent

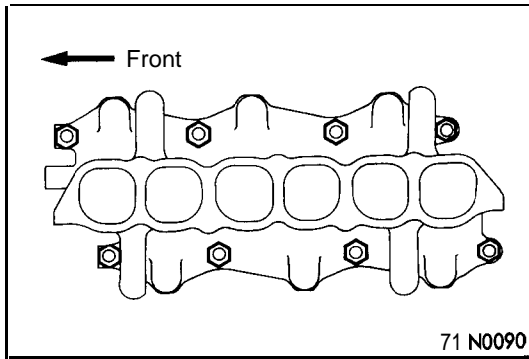

◆E◆ INTAKE MANIFOLD INSTALLATION – DOHC

- (1) Tighten the nuts on the right bank to 4 Nm (2.2 ft.lbs.).
- (2) Tighten the nuts on the left bank to the specified torque. Then tighten the nuts on right bank to the specified torque.
- (3) Tighten the nuts on the left bank and those on the right bank again in that order.

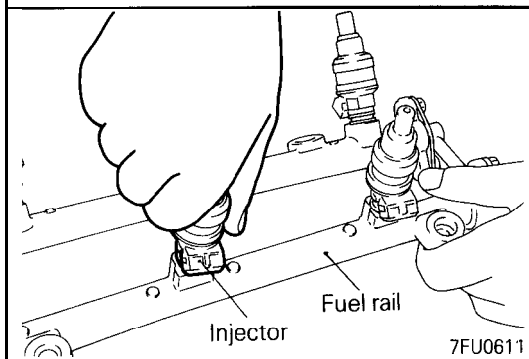

◆F◆ INSTALLATION OF INJECTOR

- (1) Before installing the injector, the rubber O-ring must be lubricated with a drop of clean engine oil for easy installation.

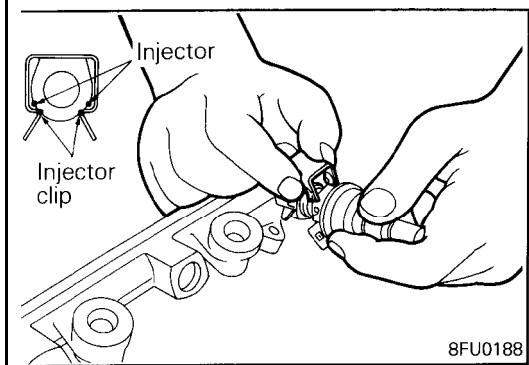

- (2) Insert the injector top end into the fuel rail. Be careful not to damage O-ring during installation.
- (3) Install the injector clip by sliding the open ends onto both injector and fuel rail.

◆G◆ FUEL PRESSURE REGULATOR INSTALLATION

- (1) Before installing the pressure regulator, the O-ring must be lubricated with a drop of clean engine oil for easy installation.

EXHAUST MANIFOLD

REMOVAL AND INSTALLATION – SOHC for DIAMANTE

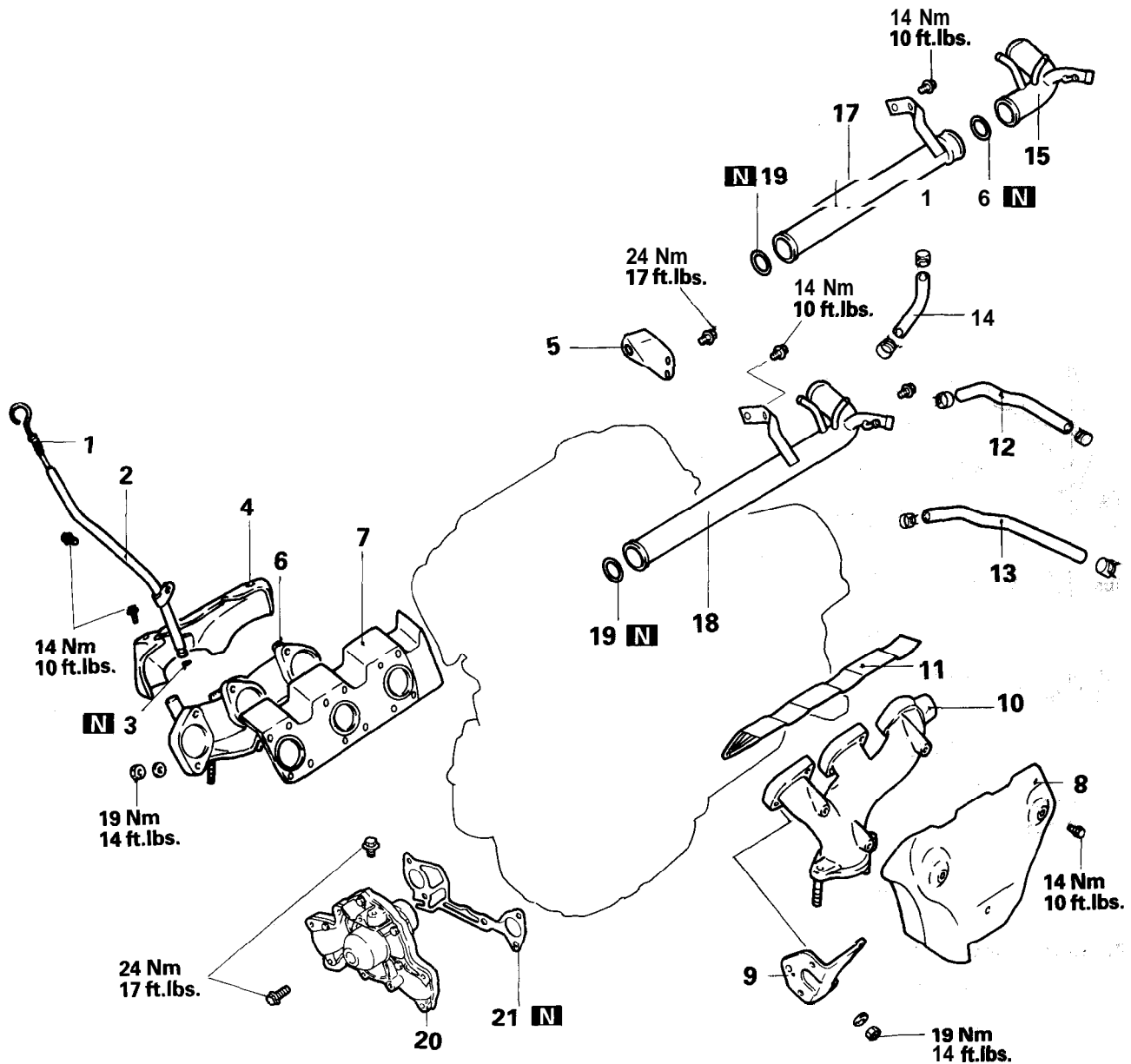

Removal steps

- | | | |
|---------------------------------|----------------------------|-----------|
| 1. Oil level gauge | ◆A◆ 15. Water inlet pipe B | } For M/T |
| 2. Oil level gauge guide | ◆A◆ 16. O-ring | |
| 3. O-ring | ◆A◆ 17. Water inlet pipe A | |
| 4. Heat protector | ◆A◆ 18. Water inlet pipe | } For A/T |
| 5. Engine hanger, right | ◆A◆ 19. O-ring | |
| 6. Exhaust manifold, right | 20. Water pump | |
| ◆B◆ 7. Exhaust manifold gasket | 21. Water pump gasket | |
| 8. Heat protector, right | | |
| 9. Bracket | | |
| 10. Exhaust manifold, left | | |
| ◆B◆ 11. Exhaust manifold gasket | | |
| 12. Water hose | | |
| 13. Water hose | | |
| 14. Water by-pass hose | | |

REMOVAL AND INSTALLATION – SOHC for MONTERO AND TRUCK

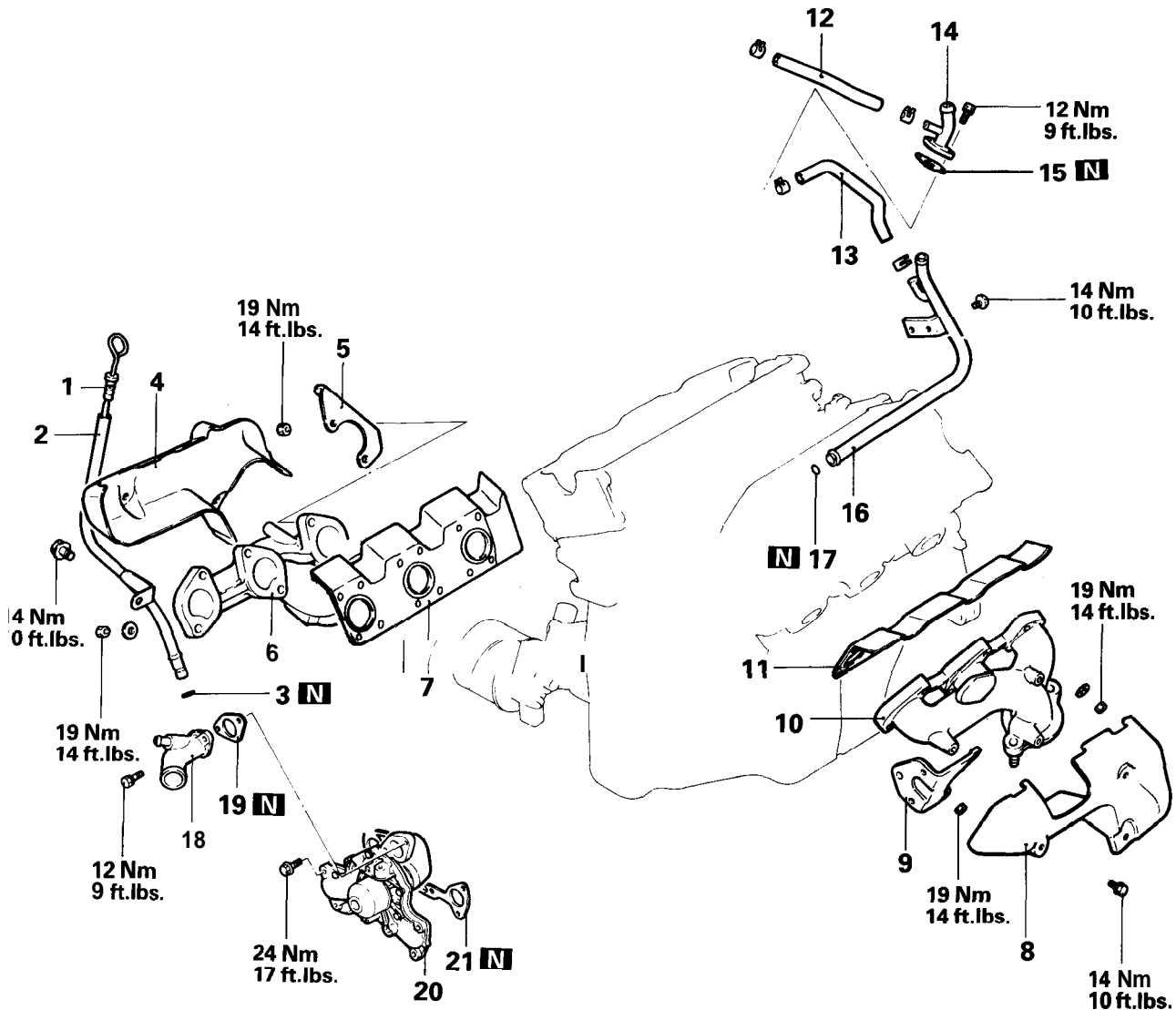

Removal steps

1. Oil level gauge
2. Oil level gauge guide
3. O-ring
4. Heat protector, right
5. Engine hanger
6. Exhaust manifold, right
- ▶▶ 7. Exhaust manifold gasket
8. Heat protector, left
9. Bracket
10. Exhaust manifold, left
- ▶▶ 11. Exhaust manifold gasket
12. Water hose
13. Water hose A
14. Heater pipe
15. Heater pipe gasket
16. Water pipe
- ▶▶ 17. O-ring
- ▶▶ 18. Water inlet pipe
19. Water inlet fitting gasket
20. Water pump
21. Water pump gasket

REMOVAL AND INSTALLATION – DOHC NON-TURBO

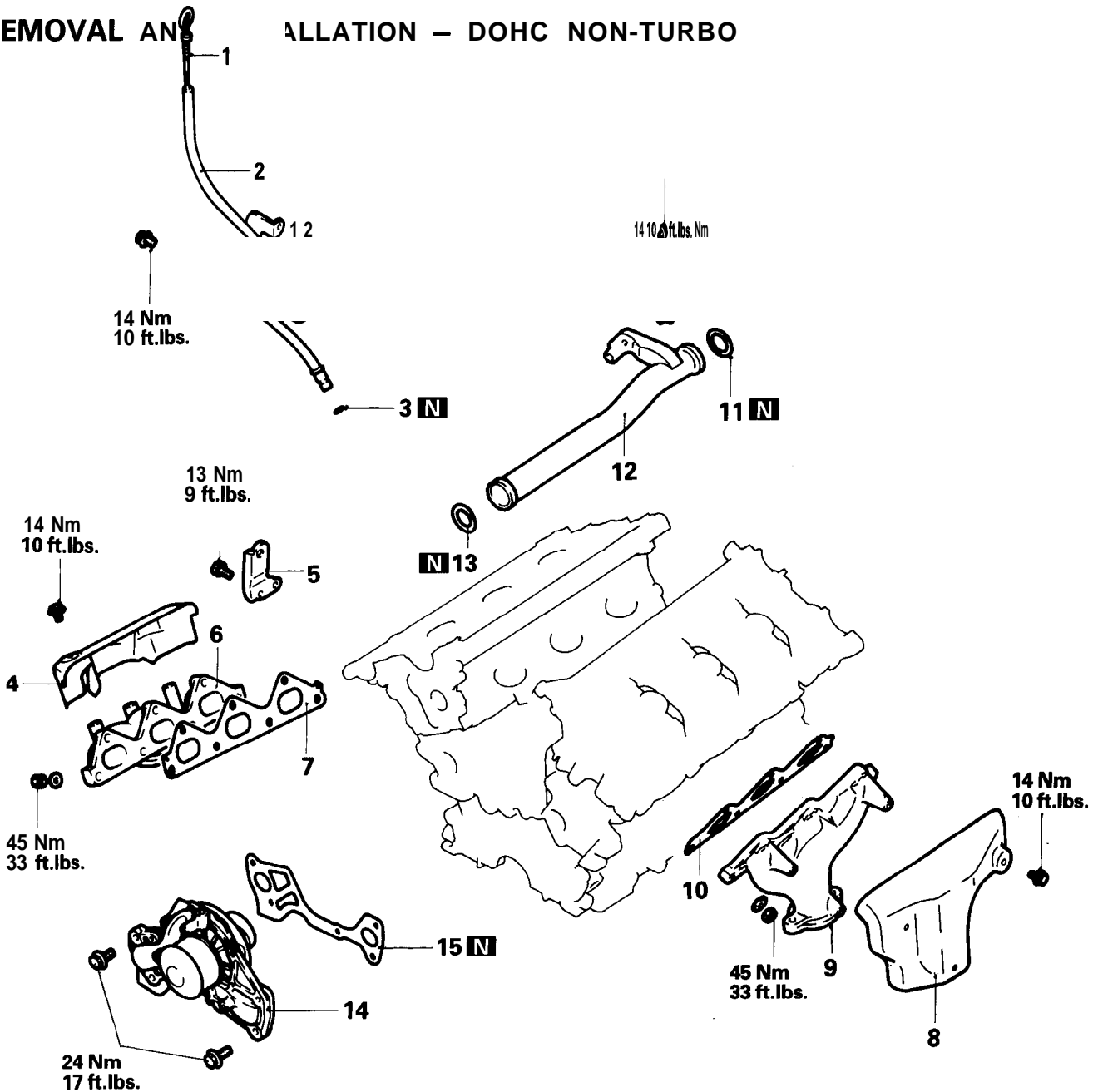

Removal steps

1. Oil level gauge
2. Oil level gauge guide
3. O-ring
4. Heat protector, right
5. Engine hanger
6. Exhaust manifold, right
7. Exhaust manifold gasket
8. Heat protector, left
9. Exhaust manifold, left
10. Exhaust manifold gasket
11. O-ring
12. Water inlet pipe
13. O-ring
14. Water pump
15. Water pump gasket

REMOVAL AND INSTALLATION – DOHC TURBO

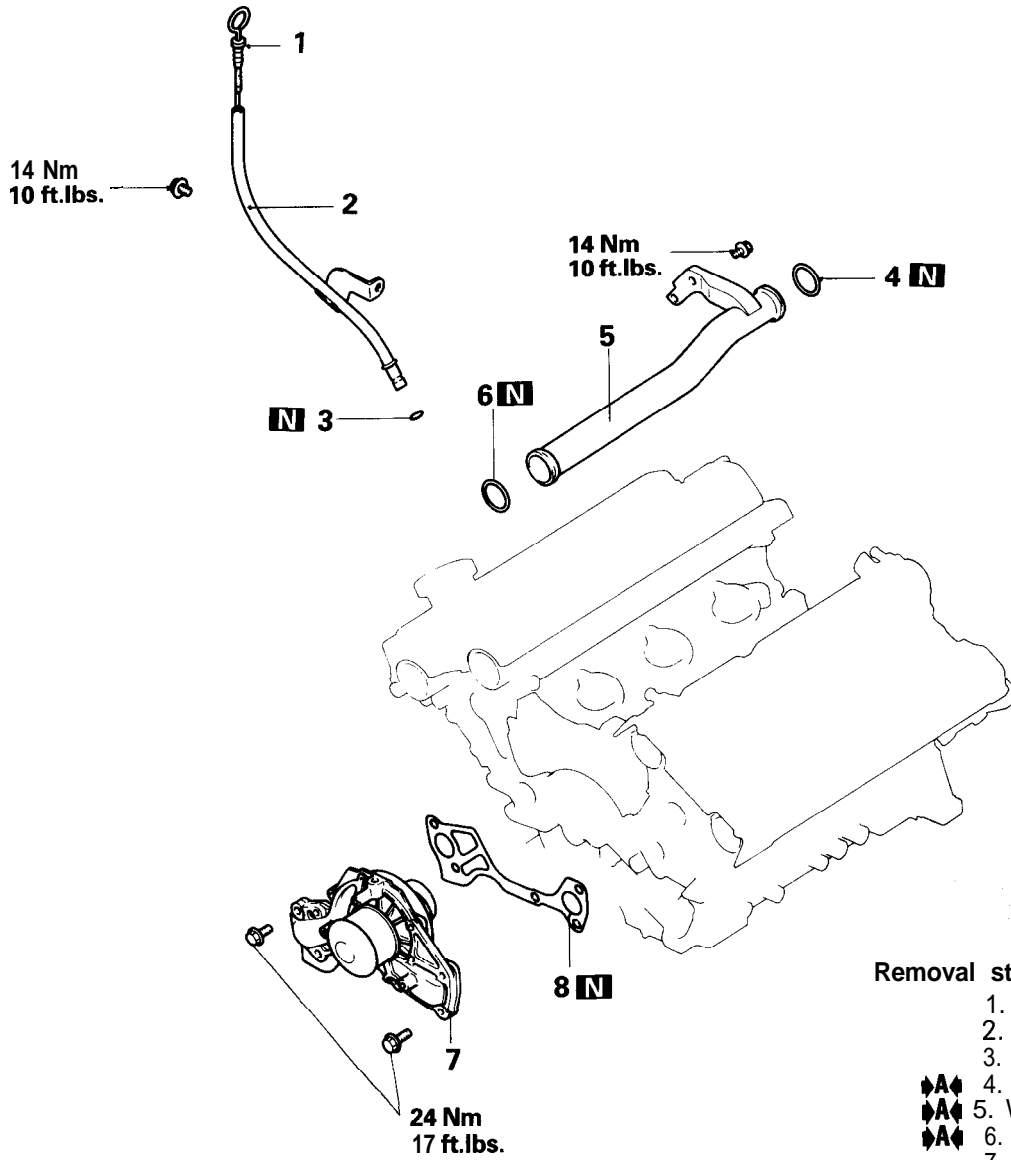

Removal steps

1. Oil level gauge
2. Oil level gauge guide
3. O-ring
- ▶▶▶ 4. O-ring
- ▶▶▶ 5. Water inlet pipe
- ▶▶▶ 6. O-ring
7. Water pump
8. Water pump gasket

7EN0504

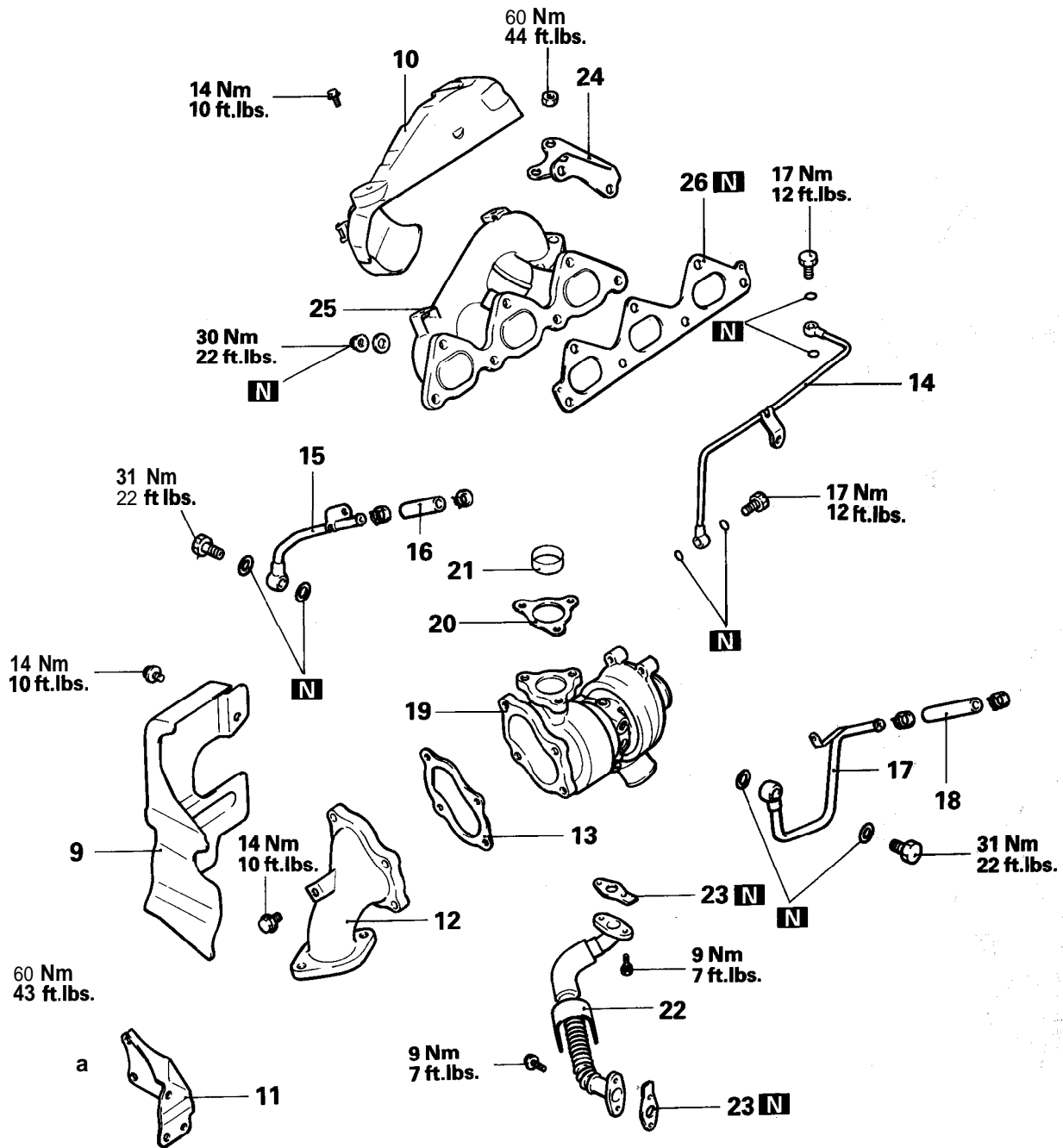

- 9. Heat protector B
- 10. Heat protector A
- 11. Turbocharger stay
- 12. Exhaust fitting
- 13. Exhaust fitting gasket
- 14. Oil pipe
- 15. Water pipe A, right
- 16. Water hose
- 17. Water pipe B, right
- 18. Water hose

- 19. Turbocharger, right
- 20. Turbocharger gasket
- 21. Ring
- 22. Oil return pipe, right
- 23. Oil return pipe gasket
- 24. Exhaust manifold stay, right
- 25. Exhaust manifold, right
- 26. Exhaust manifold gasket

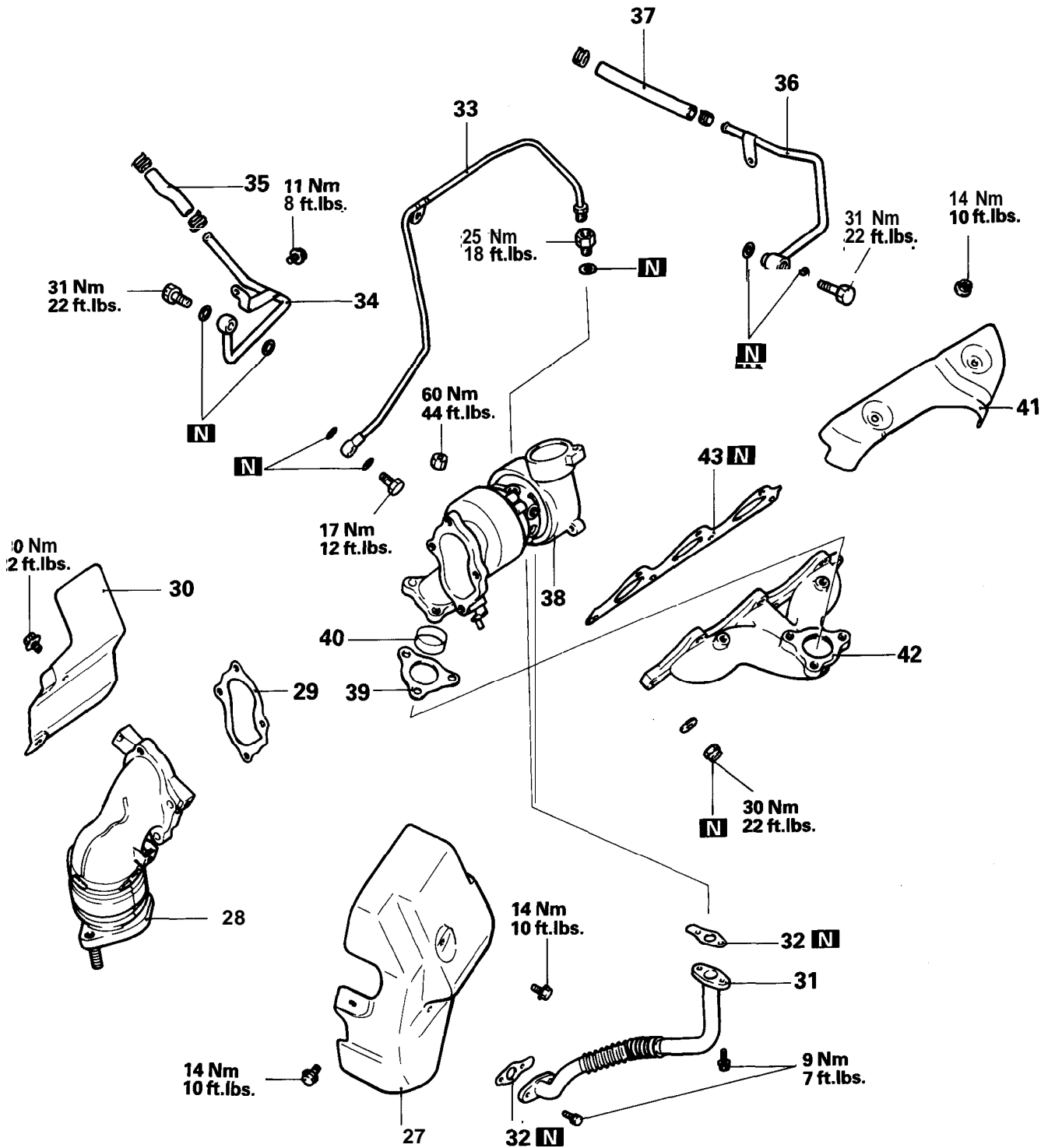

- 27. Heat protector D
- 28. Exhaust fitting, left
- 29. Exhaust fitting gasket, left
- 30. Heat protector C
- 31. Oil return pipe
- 32. Oil return pipe gasket
- 33. Oil pipe
- 34. Water pipe B, left
- 35. Water hose

- 36. Water pipe A, left
- 37. Water hose
- 38. Turbocharger, left
- 39. Turbocharger gasket
- 40. Ring
- 41. Heat protector E
- 42. Exhaust manifold, left
- 43. Exhaust manifold gasket

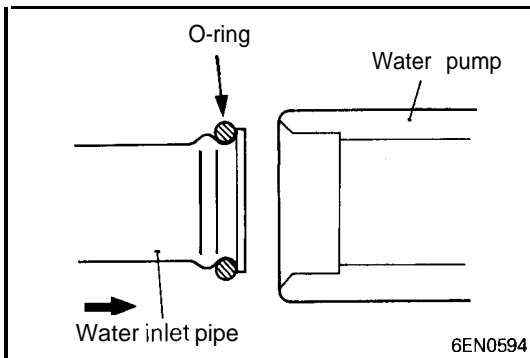

INSTALLATION SERVICE POINTS

▶A◀ O-RING AND WATER PIPE INSTALLATION

- (1) Wet the O-ring (with water) to facilitate assembly.

Caution

Keep the O-ring free of oil or grease.

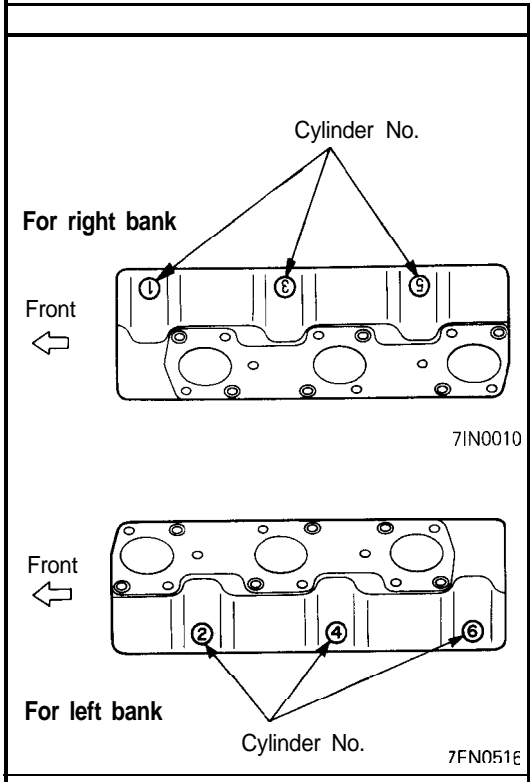

▶B◀ EXHAUST MANIFOLD GASKET IDENTIFICATION – SOHC

- (1) Install gaskets with cylinder number ①, ③ and ⑤ embossed on their top side to the right bank and install those with cylinder number ②, ④ and ⑥ to the left bank.

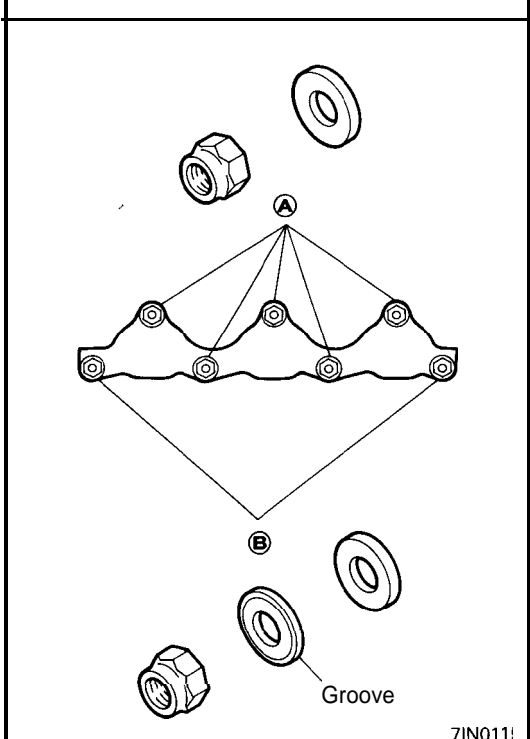

▶C◀ RIGHT EXHAUST MANIFOLD INSTALLATION – DOHC TURBO

Tighten the nuts in the following order.

- (1) Tighten five nuts **A** to 30 Nm (22 ft.lbs.).
- (2) Tighten nuts **B** to 50 Nm (36 ft.lbs.).
- (3) Back off nuts **B** until a torque value of 10 Nm (7 ft.lbs.) is achieved.
- (4) Tighten nuts **B** to 30 Nm (22 ft.lbs.).

NOTE

- (1) Fit the cone disc spring with the grooved side facing the nut.
- (2) Install the nut, cone disc spring and washer in the order shown in the illustration.

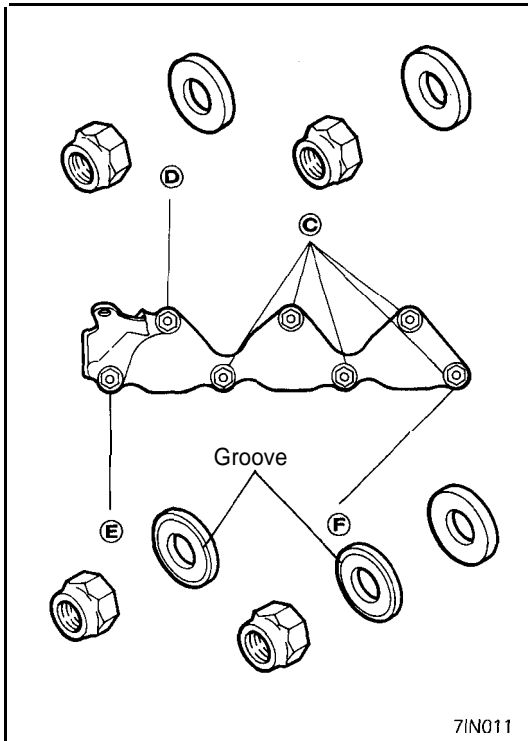

71N011

◆D◆ LEFT EXHAUST MANIFOLD INSTALLATION – DOHC TURBO

Tighten the nuts in the following order.

- (1) Tighten four nuts **C** to 30 Nm (22 ft.lbs.).
- (2) Temporarily tighten the turbocharger to the exhaust manifold.
- (3) Tighten nut **D** to 30 Nm (22 ft.lbs.).
- (4) Tighten nuts **E** and **F** to 50 Nm (36 ft.lbs.).
- (5) Back off nuts **E** and **F** until a torque value of 10 Nm (7 ft.lbs.) is achieved.
- (6) Tighten nuts **E** and **F** to 30 Nm (22 ft.lbs.).

NOTE

- (1) Fit the cone disc spring with the grooved side facing the nut.
- (2) Install the nut, cone disc spring and washer in the order shown in the illustration.

TURBOCHARGER

DISASSEMBLY AND REASSEMBLY

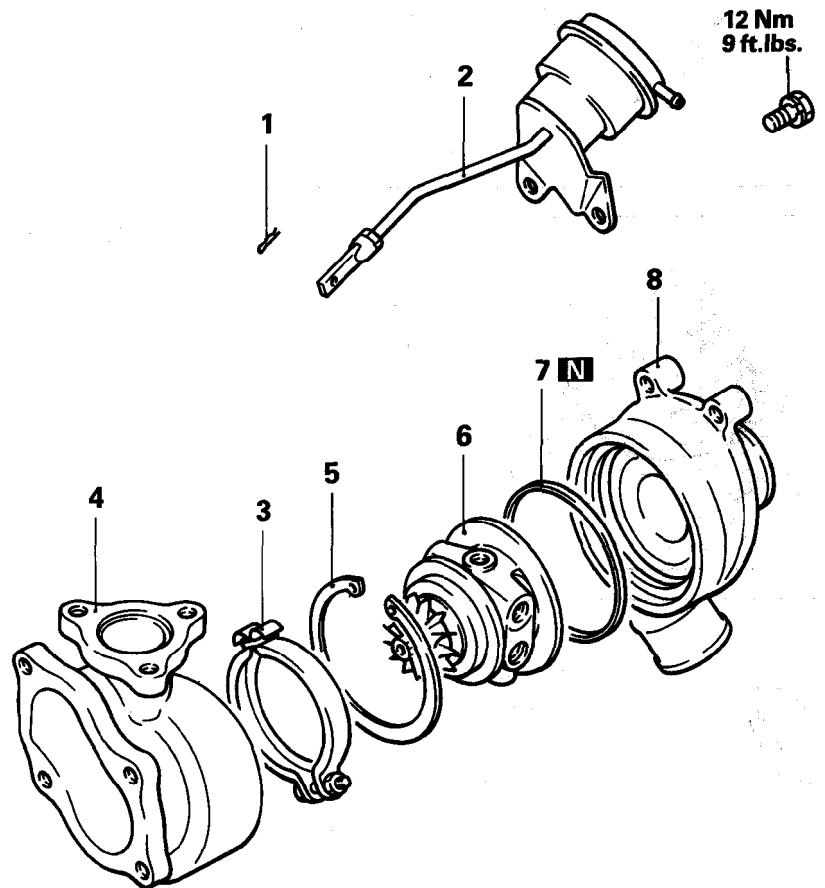

Disassembly steps

1. Snap pin
2. Turbocharger waste gate actuator
3. Coupling
- ▶D▶ 4. Turbine housing
- ▶C▶ 5. Snap ring
- ▶B▶ 6. Turbine wheel assembly
- ▶A▶ 7. O-ring
8. Compressor cover

71N0098

INSPECTION

TURBOCHARGER

- (1) Manually open and close the waste gate valve to make sure it operates freely.
- (2) Inspect the oil passage in the cartridge for signs of deposits or blockage.
- (3) Clean the inlet section of the compressor cover with a rag. Inspect it for signs of contact with the compressor turbine. If worn, replace it.

REASSEMBLY SERVICE POINTS

▶A▶ O-RING INSTALLATION

- (1) Apply a light coat of engine oil to a new O-ring and fit it in the groove of the turbine wheel assembly.

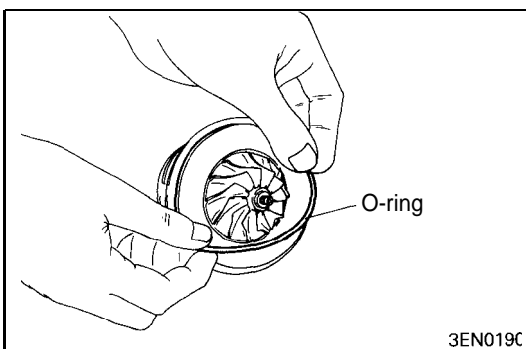

3EN019C

TSB Revision

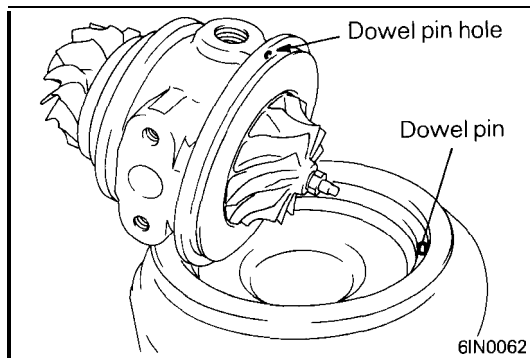

◆B◆ TURBINE WHEEL ASSEMBLY INSTALLATION

- (1) Install the turbine wheel assembly to the compressor cover while aligning the dowel pin and the hole.

Caution

Use care not to damage the blades of the turbine wheel and compressor wheel.

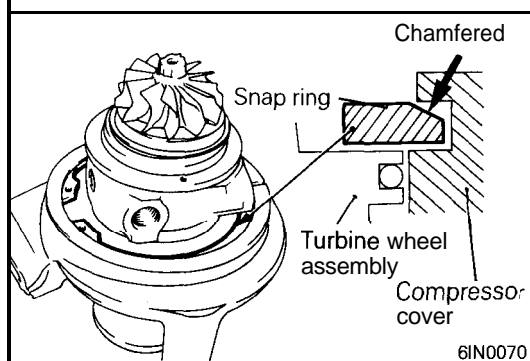

◆C◆ SNAP RING INSTALLATION

- (1) Fit the snap ring with its chamfered side facing up.

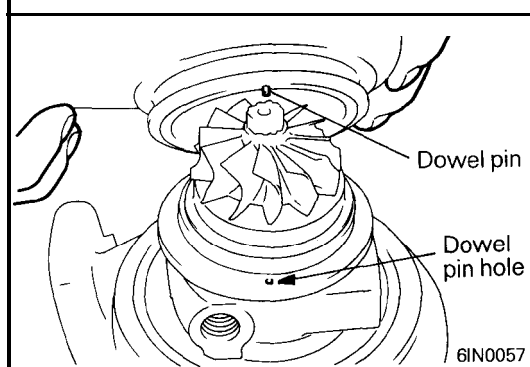

◆D◆ TURBINE HOUSING INSTALLATION

- (1) Install the turbine housing while aligning the dowel pin and the hole.

Caution

Use care not to damage the blades of the turbine wheel.

ROCKER ARMS AND CAMSHAFTS – SOHC

REMOVAL AND INSTALLATION – DIAMANTE

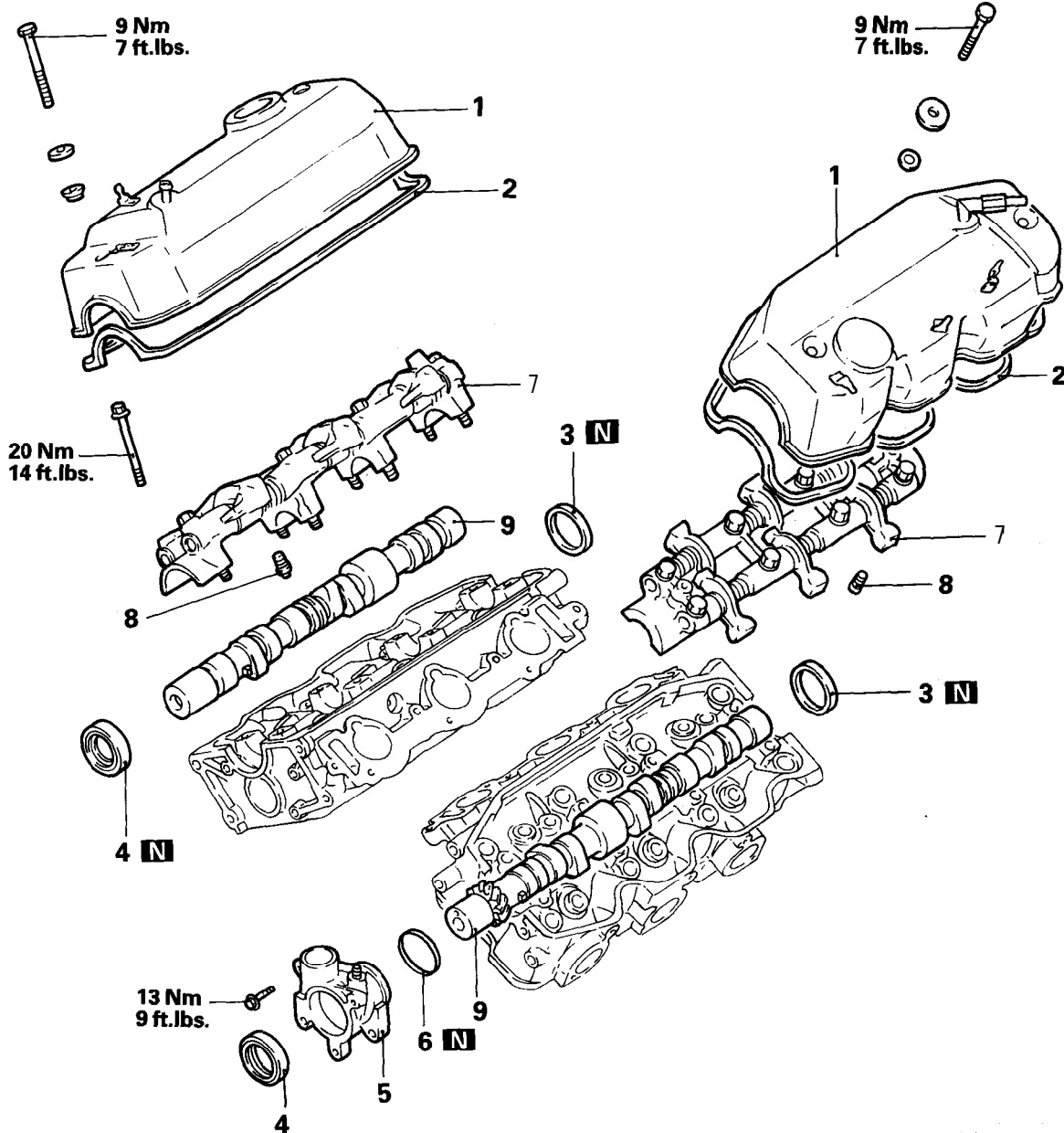

Removal steps

- ▶E◀ 1. Rocker cover
- 2. Gasket
- ▶D◀ 3. Circular packing
- ▶C◀ 4. Camshaft oil seal
- 5. Distributor adaptor
- 6. O-ring
- ▶B◀ 7. Rocker arms, shafts and bearing caps
- ◀A◀ ▶A◀ 8. Lash adjuster
- 9. Camshaft

REMOVAL AND INSTALLATION – MONTERO AND TRUCK

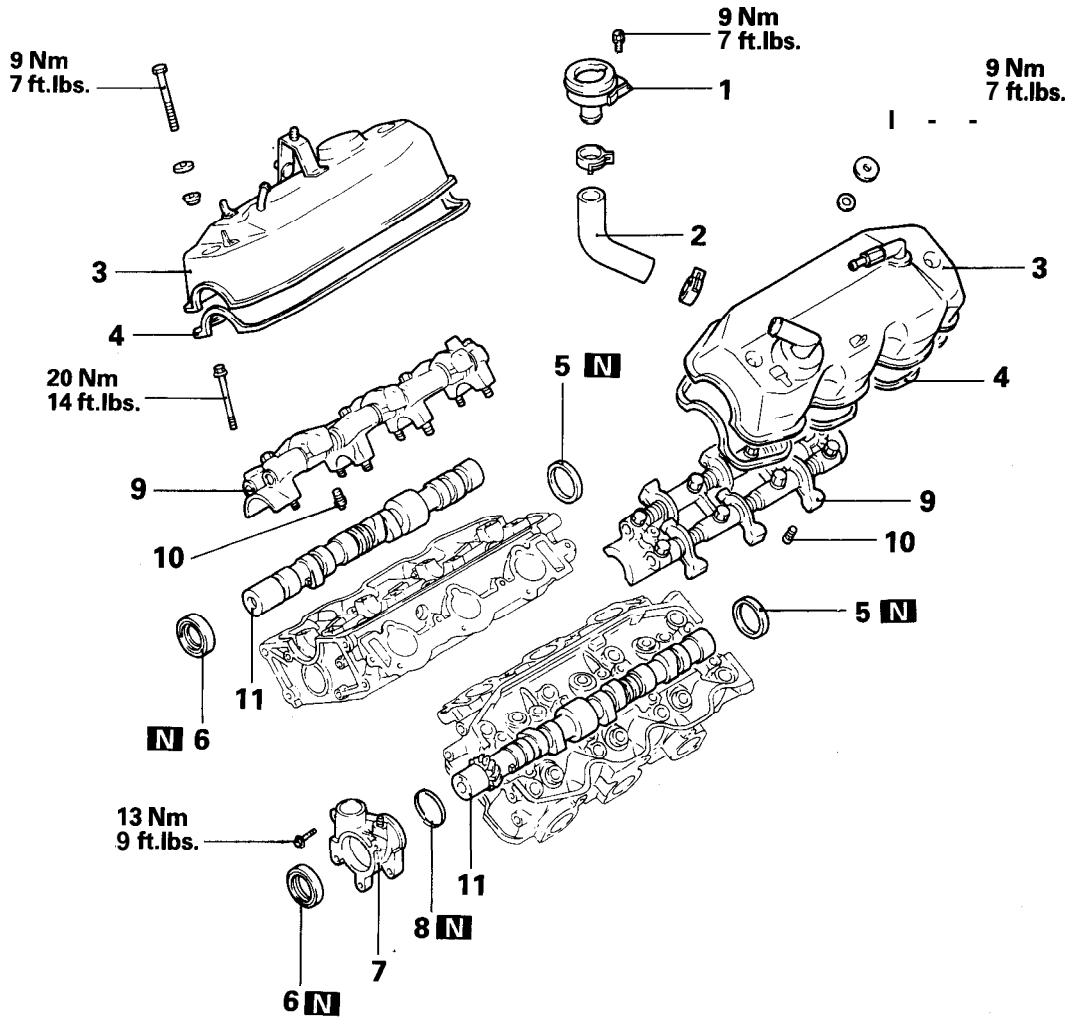

Removal steps

- 1 Oil filler
- 2 Oil filler tube
- ▶E◀ 3. Rocker cover
- 4. Gasket
- ▶D◀ 5. Circular packing
- ▶C◀ 6. Camshaft oil seal
- 7. Distributor adaptor
- 8. O-ring
- ▶B◀ 9. Rocker arms, shafts and bearing caps
- ◀A▶ ▶A◀ 10. Lash adjuster
- 11. Camshaft

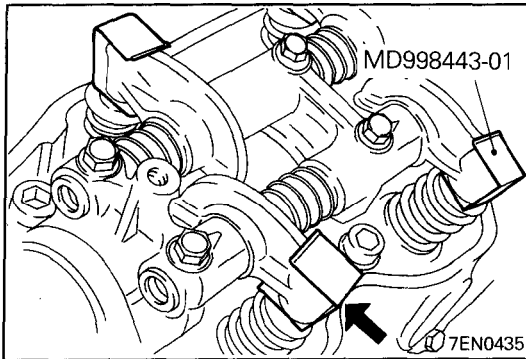
**REMOVAL SERVICE POINT****ROCKER ARM, SHAFT AND BEARING CAP REMOVAL**

- (1) Install the special tools to the rocker arm to hold the lash adjuster.
- (2) Loosen the camshaft bearing cap bolt. Do not remove the bolts from the cap.
- (3) Remove the rocker arm, shaft and bearing cap as an assembly.

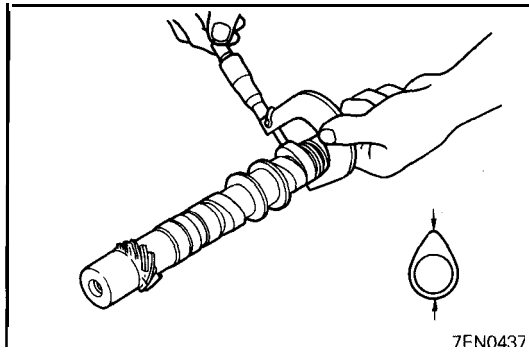
**INSPECTION****CAMSHAFT**

- (1) Inspect the camshaft bearing journals for damage and binding. If the journals are binding, also check the cylinder head for damage. Also check the cylinder head oil holes for clogging.
- (2) Check the tooth surface of the distributor drive gear teeth of the camshaft and replace if abnormal wear is evident.
- (3) Check the cam surface for abnormal wear and damage and replace if defective. Also measure the cam height and replace if out of limit.

Standard value: 41.25 mm (1.6240 in.)

Limit: 40.75 mm (1.6643 in.)

LASH ADJUSTER LEAK DOWN TEST**Caution**

1. The lash adjuster is a precision part. Keep it free from dust and other foreign matters.
2. Do not disassemble the lash adjusters.
3. When cleaning the lash adjusters, use clean diesel fuel only.

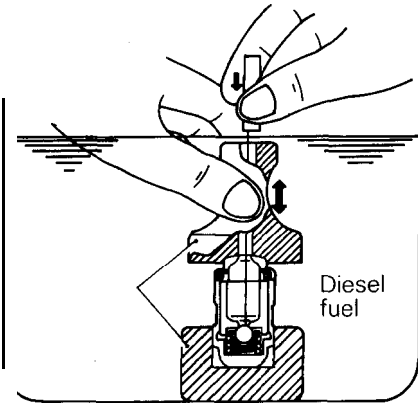

6EN057

- (1) Immerse the lash adjuster in clean diesel fuel.
- (2) While lightly pushing down the inner steel ball using the small wire, move the plunger up and down four or five times to bleed air.
Use of the Retainer facilitates the air bleeding of the rocker arm mounted type lash adjuster.
- (3) Remove the small wire and press the plunger. If the plunger is hard to be pushed in, the lash adjuster is normal. If the plunger can be pushed in all the way readily, bleed the lash adjuster again and test again. If the plunger is still loose, replace the lash adjuster.

Caution

Upon completion of air bleeding, hold the lash adjuster upright to prevent the inside diesel fuel from spilling.

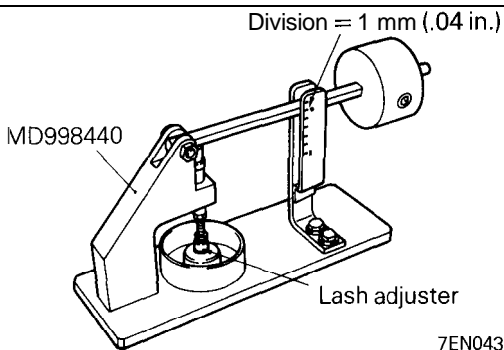

7EN0438

- (4) After air bleeding, set the lash adjuster on the special tool (Leak down tester MD998440).
- (5) After the plunger has gone down somewhat 0.2 – 0.5 mm (.008 – .020 in.), measure the time taken for it to go down 1 mm (.04 in.). Replace if the measured time is out of specification.

**Standard value: 4 – 20 seconds / 1 mm (.04 in.)
[Diesel fuel at 15 – 20°C (50 – 68°F)]**

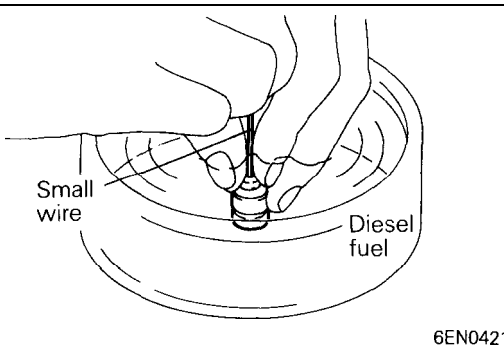

6EN0421

INSTALLATION SERVICE POINTS**◆◆ LASH ADJUSTER INSTALLATION**

- (1) Immerse the lash adjuster in clean diesel fuel.
- (2) Using a small wire, move the plunger up and down 4 or 5 times while pushing down lightly on the check ball in order to bleed out the air.

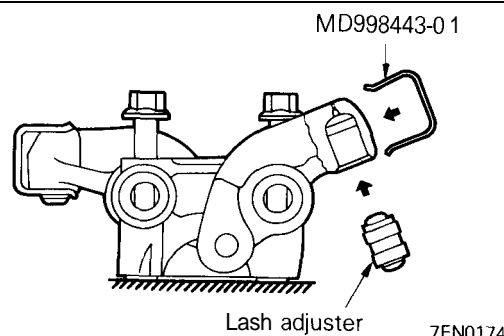

7EN0174

- (3) Insert the lash adjuster to rocker arm, being careful not to spill the diesel fuel. Then use the special tool to prevent the adjuster from falling while installing it.

B **ROCKER ARM, SHAFT AND BEARING CAP
INSTALLATION**

- (1) Apply a minimum amount of the specified sealant on the four places of the cylinder head.

NOTE

Be sure the sealing agent does not swell out onto the cam journal surface of the cylinder head. If it swells out, immediately wipe it off before it can dry.

Specified sealant:

3M NUT Locking No. 4171 or equivalent

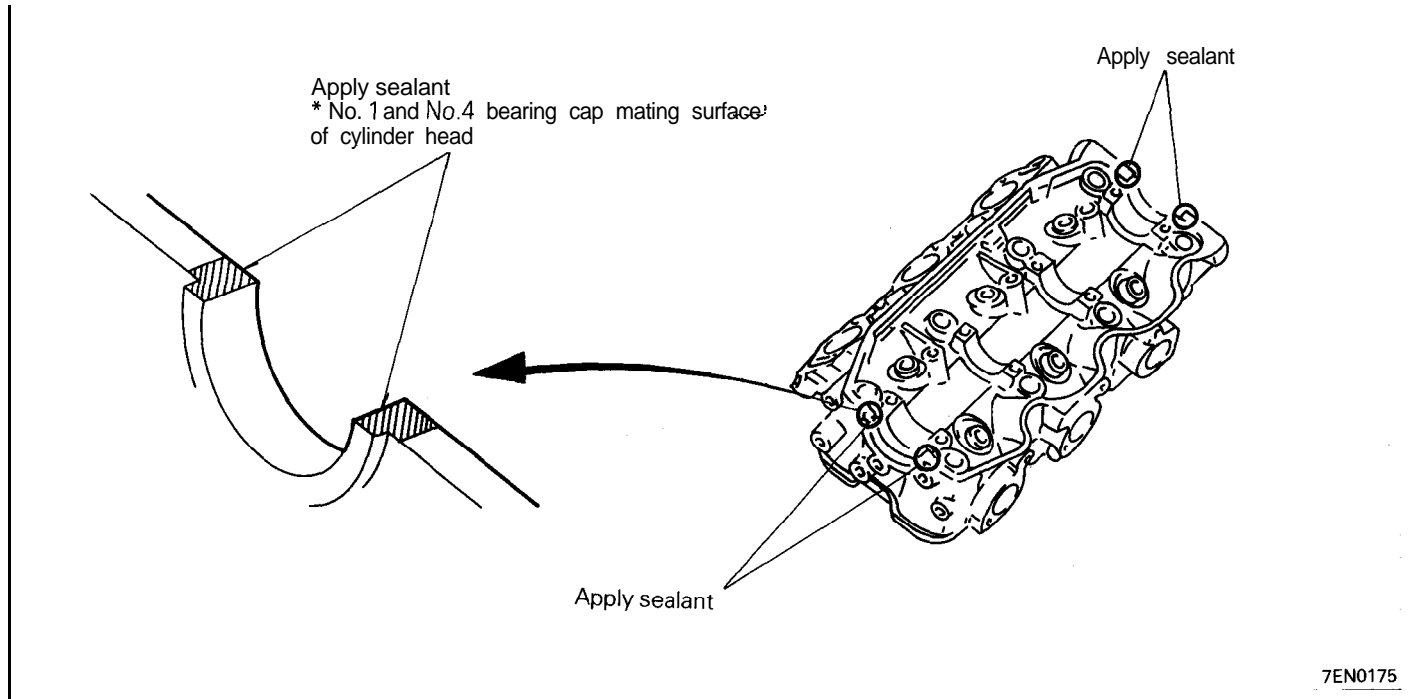

- (2) Install the rocker arms, shafts and bearing caps such that the arrow mark on the bearing cap faces in the same direction as the arrow mark on the cylinder head.

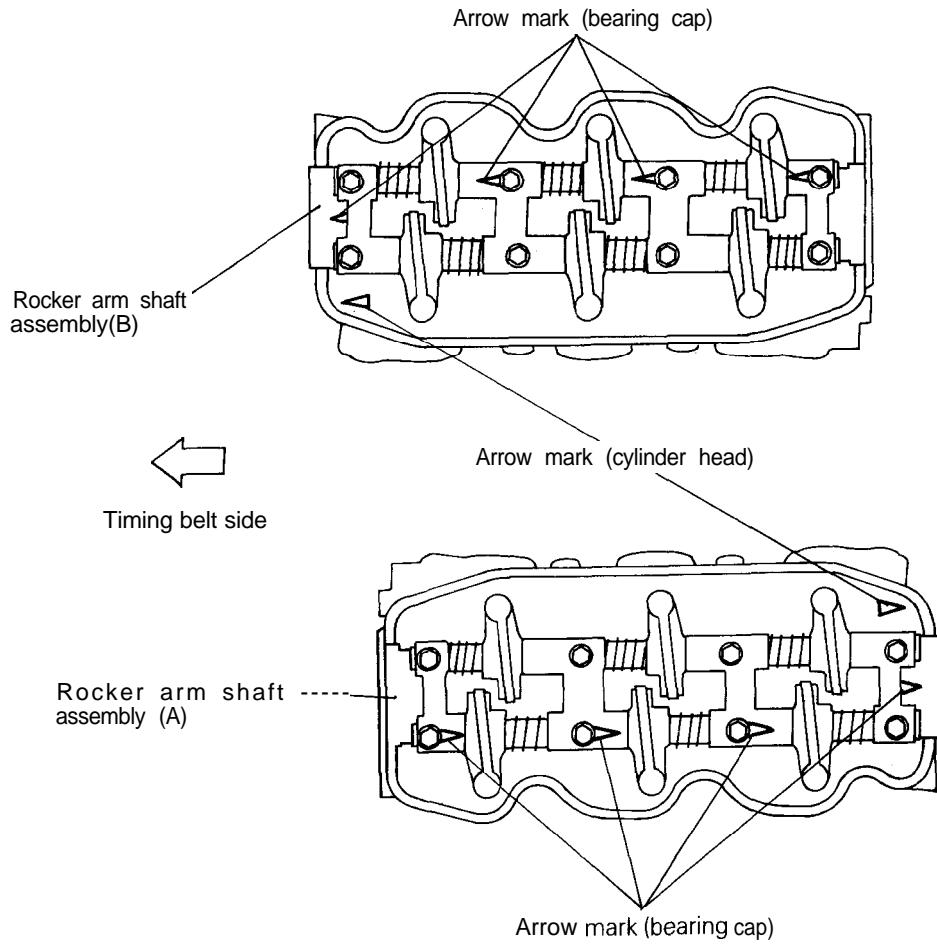

7EN0176

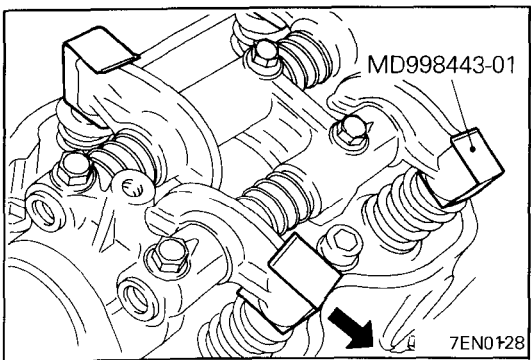

- (3) Tighten the bearing cap bolts to the specified torque.
- (4) Remove the special tools from all rocker arms.

7EN0128

▶◀ CAMSHAFT OIL SEAL INSTALLATION

- (1) Apply a slight amount of engine oil all over the circumference of the camshaft oil seal lip.
- (2) Using the special tool, insert the oil seal.

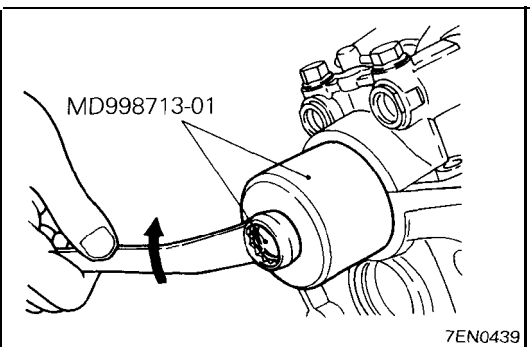

7EN0439

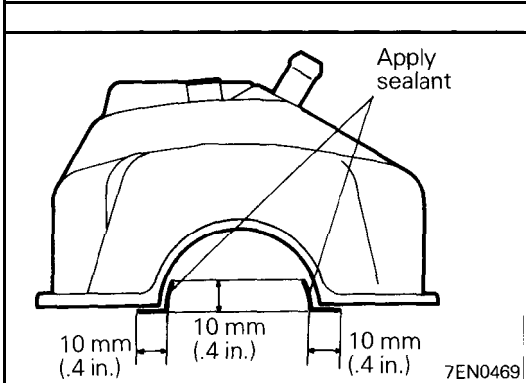
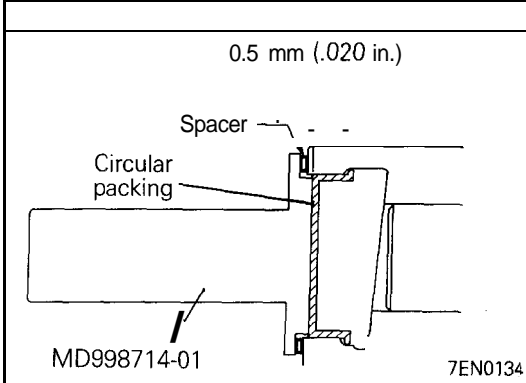
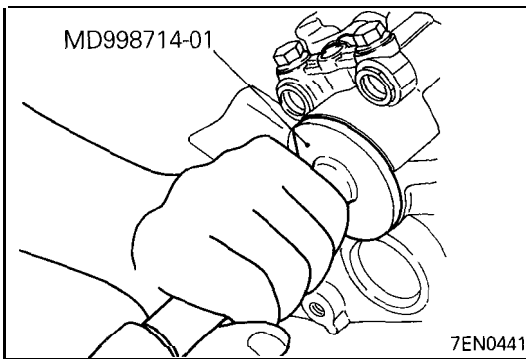

◆D◆ CIRCULAR PACKING INSTALLATION

- (1) Install a 1.3 to 1.5 mm (.052 to .059 in.) thick spacer to the special tool and drive in the circular packing.

NOTE

Use of MD724328 spacer for transmission is recommended.

Caution

The packing is overdriven if no spacer is fitted to the special tool.

◆E◆ ROCKER COVER INSTALLATION

- (1) Apply specified sealant on the area specified in the illustration.

Specified sealant:

3M ATD Part No. 6660 or equivalent

DISASSEMBLY AND REASSEMBLY

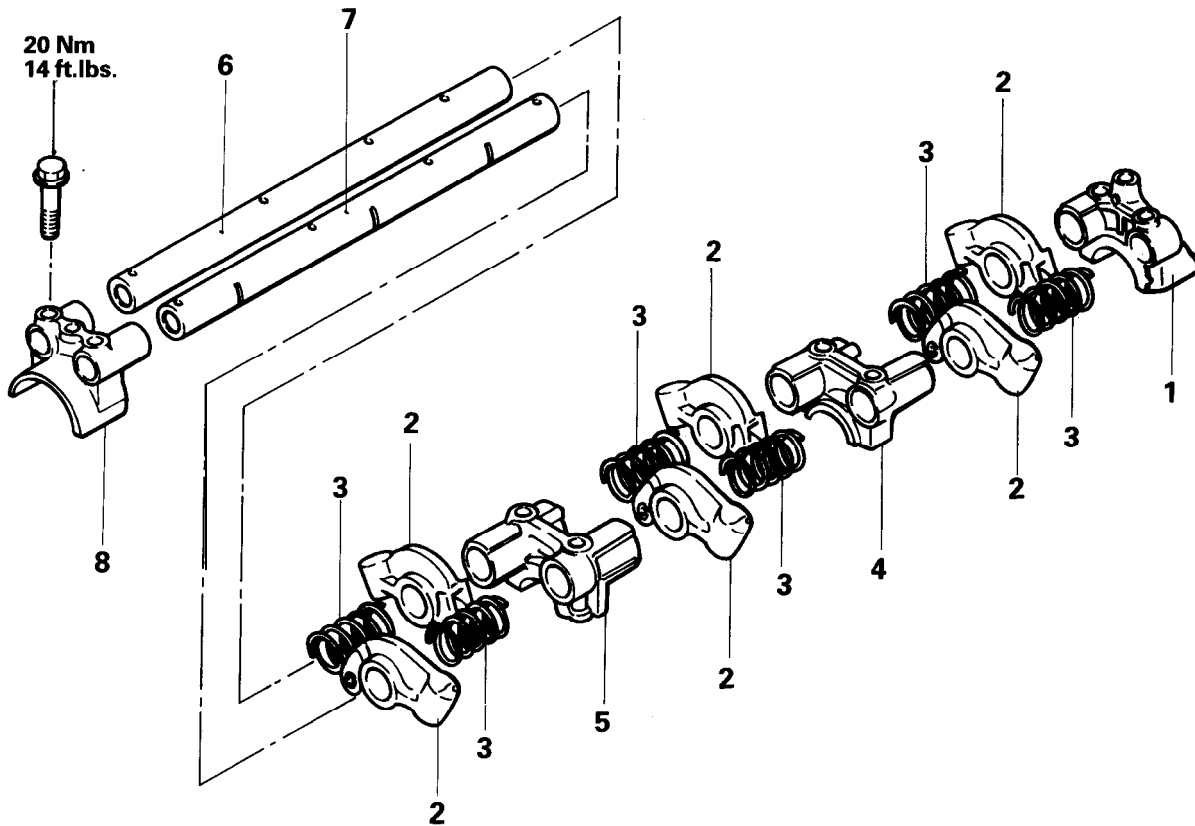

Disassembly steps

- 1. Bearing cap No.4
- ◊A◊ 2. Rocker arm
- 3. Spring
- 4. Bearing cap No. 3
- 5. Bearing cap No. 2
- ♦♦A♦ 6. Rocker arm shaft "B"
- ♦♦A♦ 7. Rocker arm shaft "A"
- 8. Bearing cap No. 1

7EN0078

DISASSEMBLY SERVICE POINT

◊A◊ **ROCKER ARM REMOVAL**

(1) Before disassembly, identify the original location of each rocker arm by a symbol.

For example, put symbols as shown below.

1 IN: For No.1 cylinder intake

6EX: For No.6 cylinder exhaust

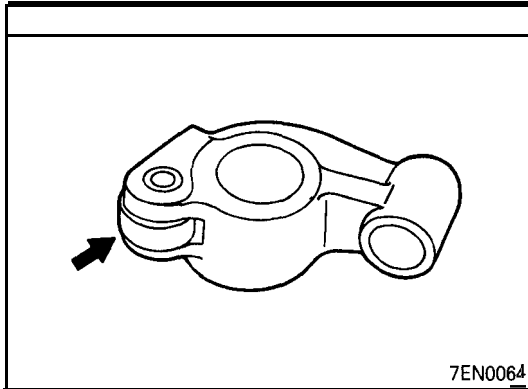

INSPECTION

ROCKER ARM

- (1) Check the roller surface and replace the rocker arm if recesses, damage or heat seizure is observed.
- (2) Check roller rotation and replace the rocker arm if uneven rotation or roller backlash is observed.
- (3) Check the inside diameter and replace the rocker arm if damage or seizure is observed.

ROCKER ARM SHAFT

- (1) Check the rocker arm mounting portions of the rocker arm shafts for wear or damage. Replace as necessary.
- (2) Check to ensure that the oil holes are clear.

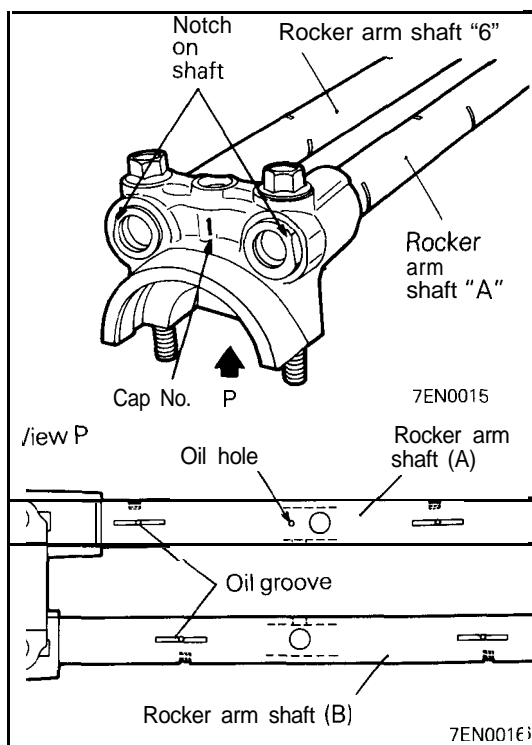

REASSEMBLY SERVICE POINT

ROCKER ARM SHAFT INSTALLATION

- (1) Install the rocker arm shafts "A" and "B" to the camshaft bearing cap No.1 and insert the bolts into the holes of the bearing cap and shafts.
- (2) Install the rocker arm shafts with the notched side facing the bearing cap No.1 and the oil grooved side facing downward. The shaft with a smaller oil hole is the rocker arm shaft "A".

- (3) Install the rocker arms, springs and camshaft bearing caps as illustrated. The rocker arms are all equally shaped. Assemble the rocker arms according to the symbols put before disassembly. The bearing caps are also equally shaped. Assemble the caps according to the identification marks as to right and left banks put before disassembly.

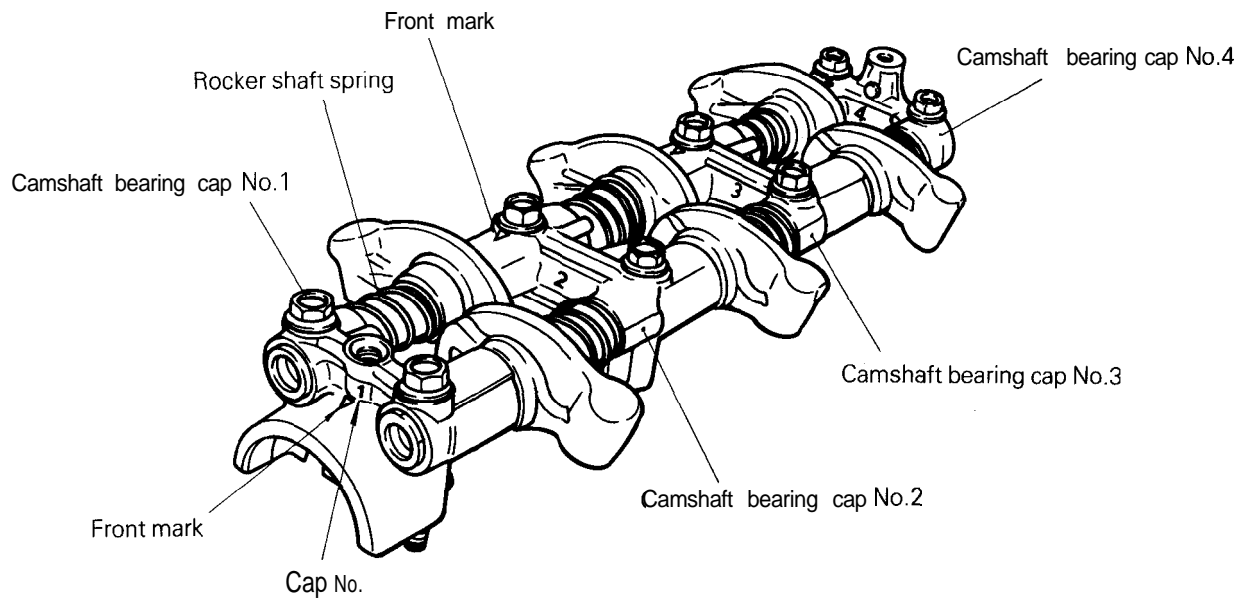

7EN0079

CAMSHAFTS, ROCKER ARMS AND BEARING CAPS – DOHC

REMOVAL AND INSTALLATION

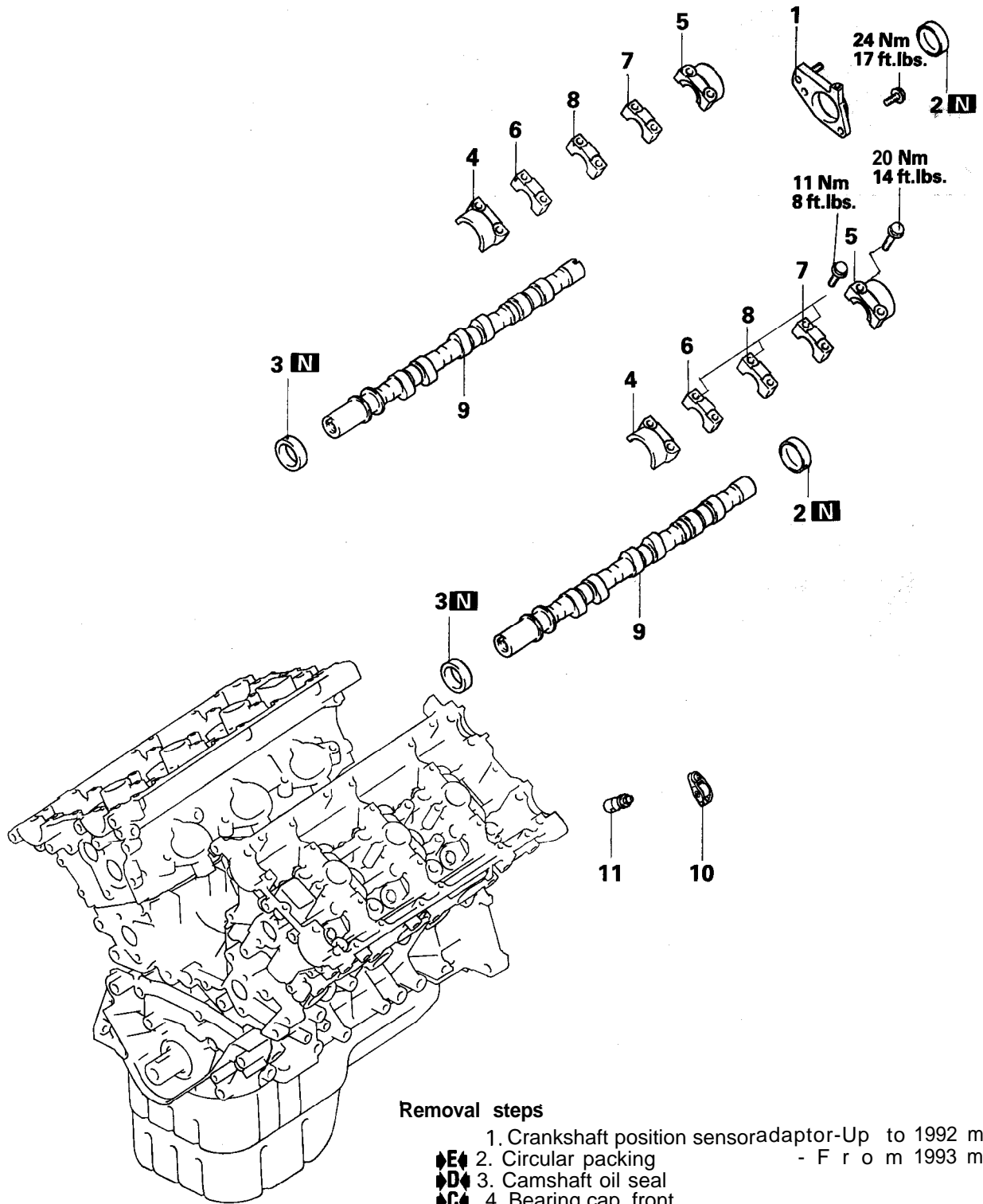

Removal steps

1. Crankshaft position sensor adaptor-Up to 1992 models
- F r o m 1993 models
- ▶E▶ 2. Circular packing
- ▶D▶ 3. Camshaft oil seal
- ▶C▶ 4. Bearing cap, front
- ▶C▶ 5. Bearing cap, rear
- ▶C▶ 6. Bearing cap No. 2
- ▶C▶ 7. Bearing cap No. 4
- ▶C▶ 8. Bearing cap No. 3
- ▶B▶ 9. Camshaft
- ▶▶ 10. Rocker arm
- ▶A▶ 11. Lash adjuster

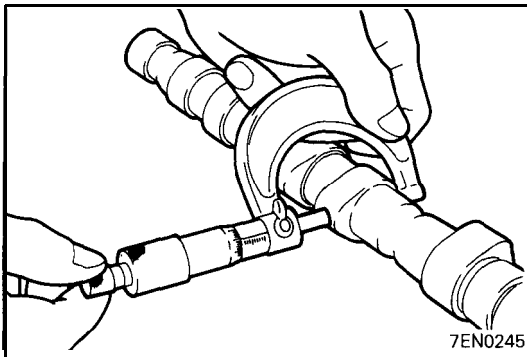

INSPECTION

CAMSHAFT

Measure the cam height (longer diameter of the cam). If it exceeds the limit, replace the camshaft.

Standard value:

Up to 1992 models

Intake side 35.49 mm (1.3972 in.)

Exhaust side 35.20 mm (1.3858 in.)

From 1993 models

Intake side 34.91 mm (1.3744 in.)

Exhaust side 34.91 mm (1.3744 in.)

Limit:

Up to 1992 models

Intake side 34.99 mm (1.3778 in.)

Exhaust side 34.70 mm (1.3661 in.)

From 1993 models

Intake side 34.41 mm (1.3547 in.)

Exhaust side 34.41 mm (1.3547 in.)

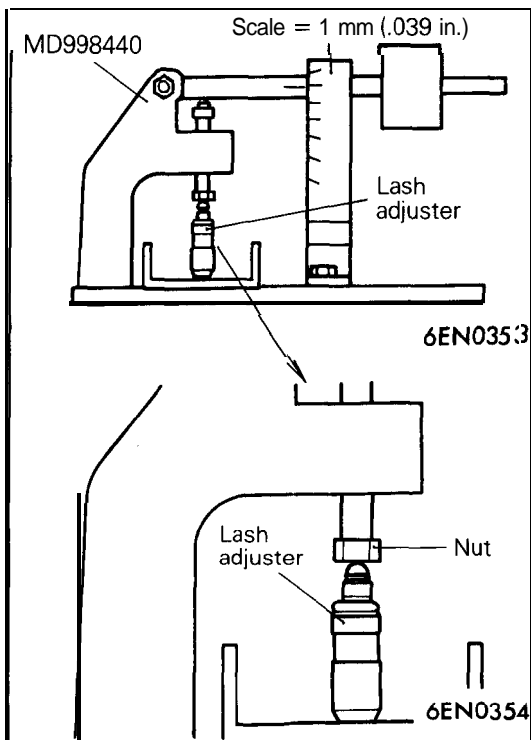

LASH ADJUSTER LEAK DOWN TEST

Refer to "LASH ADJUSTER LEAK DOWN TEST" on pages 11E-79 and 11 E-80. Also note the following:

When the lash adjuster is set on a tester, remove the adjusting screw of the tester and adjust it to the height of the lash adjuster as shown in the illustration.

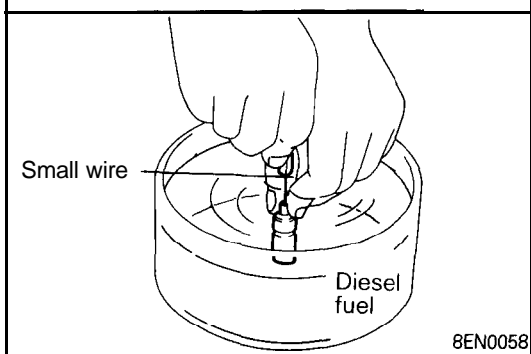

INSTALLATION SERVICE POINTS

◆A◆ LASH ADJUSTER INSTALLATION

- (1) Immerse the lash adjuster in clean diesel fuel.
- (2) Using a small wire, move the plunger up and down 4 or 5 times while lightly pushing down the check ball in order to bleed out the air.
- (3) Install the lash adjuster to the cylinder head.

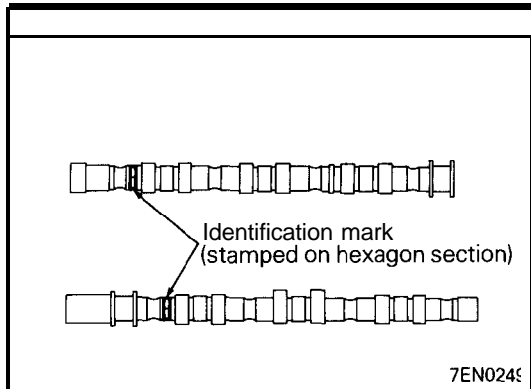

▶◀ CAMSHAFT INSTALLATION

- (1) Turn the crankshaft to bring No.1 cylinder to the top dead center.
- (2) Check that the rocker arm is installed correctly on the lash adjuster and valve.
- (3) Install the camshaft while noting the identification mark (stamped on the hexagon section).

Identification mark:		Up to 1992 models	From 1993 models
Turbo	Intake side	B	J
	Exhaust side	D	N
Non-turbo	Intake side	B	J
	Exhaust side	D	K

- (4) Install the camshafts with their dowel pins positioned as shown in the illustration.

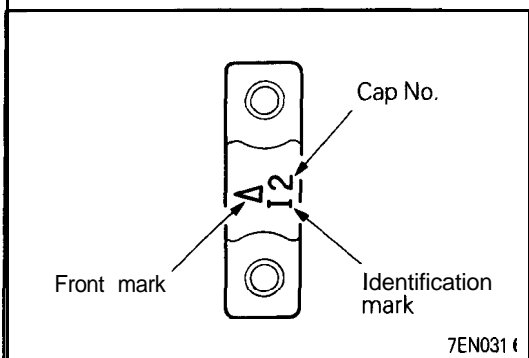
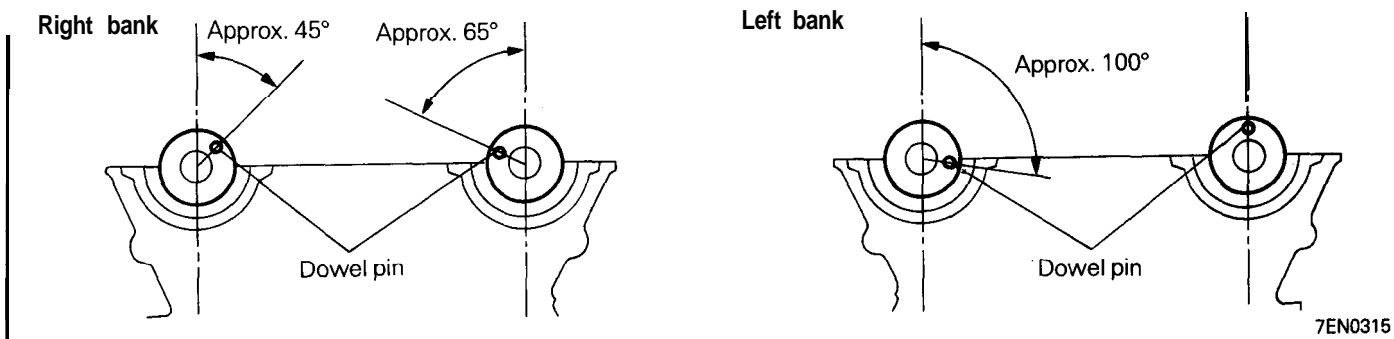

▶◀ BEARING CAP INSTALLATION

- (1) Install the bearing caps according to the identification mark and cap number. No.2, 3 and 4 bearing caps bear the front mark. Install these caps with the front mark directed in the same direction as that on the cylinder head.

Identification mark: Intake side **I**
Exhaust side **E**

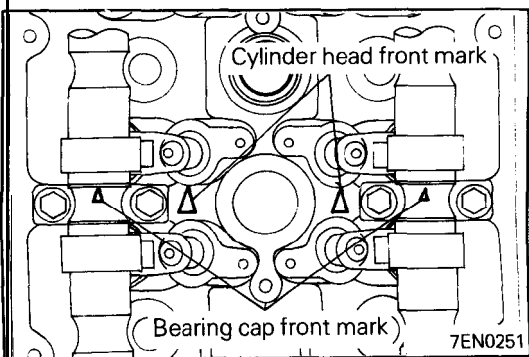

- (2) Gradually tighten the bearing caps in two or three steps. In the final step, tighten to the specified torque.

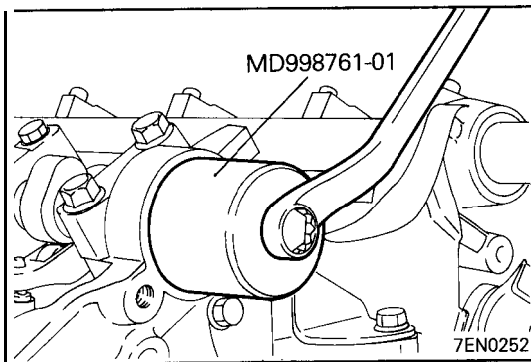
**▶D▶ CAMSHAFT OIL SEAL**

- (1) Apply engine oil sparingly all around the lip of the camshaft oil seal.
- (2) Using the special tool, install the oil seal.

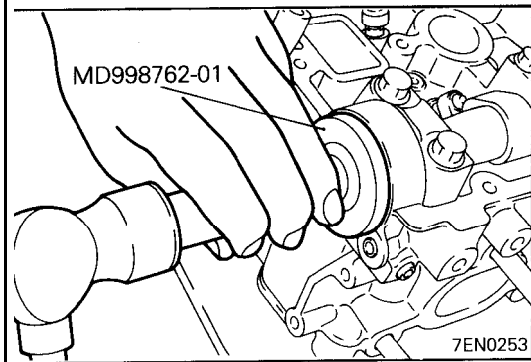
**▶E▶ CIRCULAR PACKING**

- (1) Install the circular packing with the special tool.

CYLINDER HEAD AND VALVE – SOHC

REMOVAL AND INSTALLATION

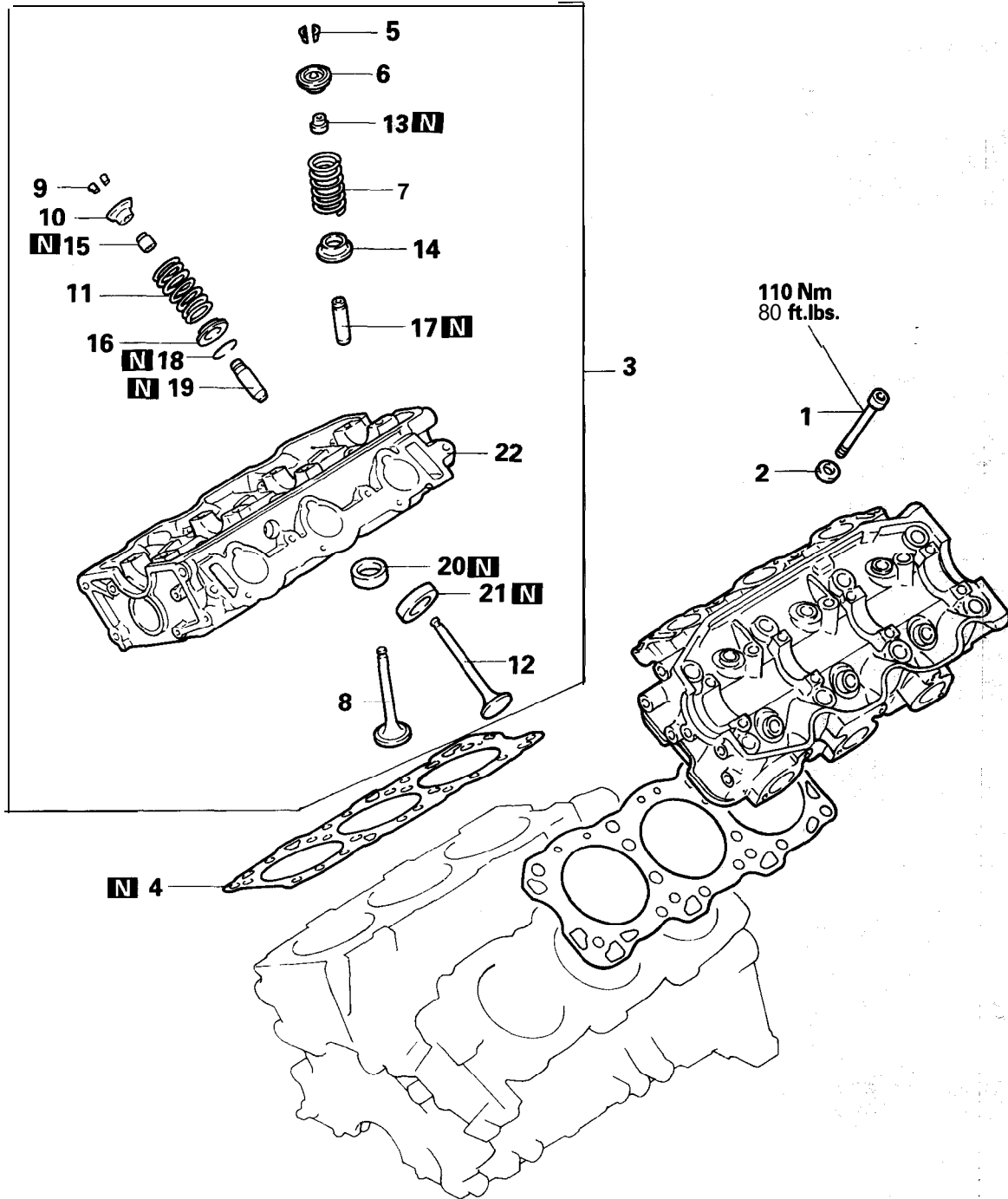

Removal steps

- ◊A◊ ◊E◊ 1. Cylinder head bolt
- 2. Washer
- 3. Cylinder head assembly
- ◊D◊ 4. Cylinder head gasket
- ◊B◊ ◊C◊ 5. Retainer lock
- 6. Valve spring retainer
- ◊B◊ 7. Valve spring
- 8. Inlet valve
- ◊B◊ ◊C◊ 9. Retainer lock
- 10. Valve spring retainer

- ◊B◊ 11. Valve spring
- 12. Exhaust valve
- ◊C◊ ◊A◊ 13. Valve stem seal
- 14. Valve spring seat
- ◊C◊ ◊A◊ 15. Valve stem seal
- 16. Valve spring seat
- 17. Inlet valve guide
- 18. Snap ring
- 19. Exhaust valve guide
- 20. Inlet valve seat
- 21. Exhaust valve seat
- 22. Cylinder head

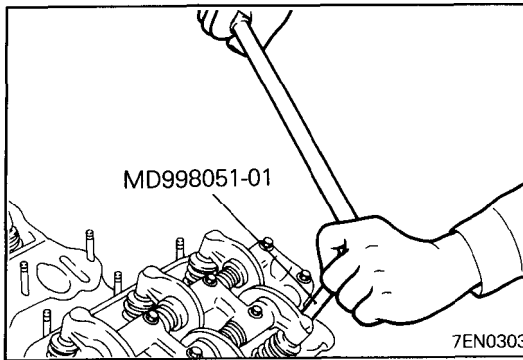
**REMOVAL SERVICE POINTS****PRECAUTION FOR REMOVED PARTS**

- (1) Keep removed parts in order according to the cylinder number and intake/exhaust.

◊A◊ CYLINDER HEAD BOLT REMOVAL

- (1) Using the special tool, loosen the cylinder head bolts. Loosen evenly, little by little.

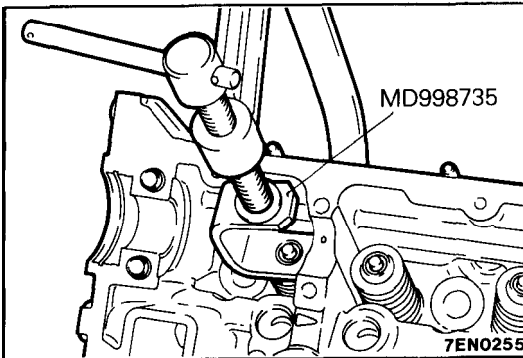
**◊B◊ RETAINER LOCK REMOVAL**

- (1) Using the special tool, compress the spring.
- (2) Remove the retainer locks.

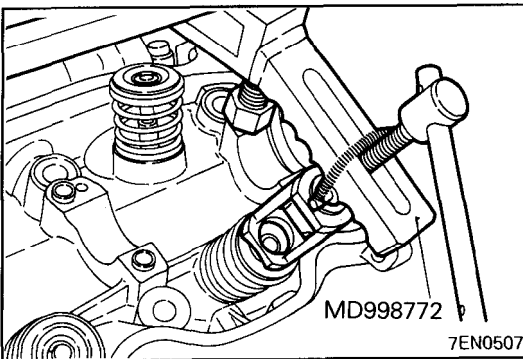
**◊C◊ VALVE STEM SEAL REMOVAL**

- (1) Do not reuse removed valve stem seals.

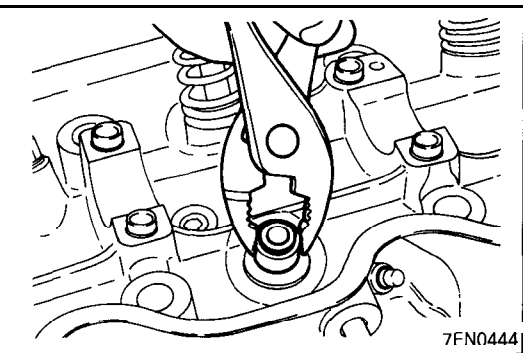

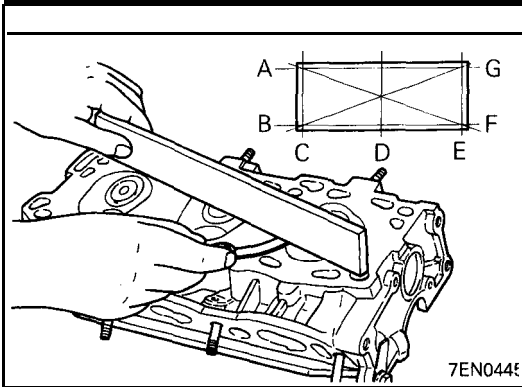

INSPECTION

CYLINDER HEAD

- (1) Check the cylinder head gasket surface for flatness by using a straightedge in the directions of A through G shown in the illustration.

Standard value: 0.05 mm (.0020 in.)

Limit: 0.2 mm (.008 in.)

- (2) If the service limit is exceeded, correct to meet the specification.

Grinding limit: *0.2 mm (.008 in.)

* Total resurfacing depth of both cylinder head and cylinder block.

Overall height: 84 mm (3.31 in.)

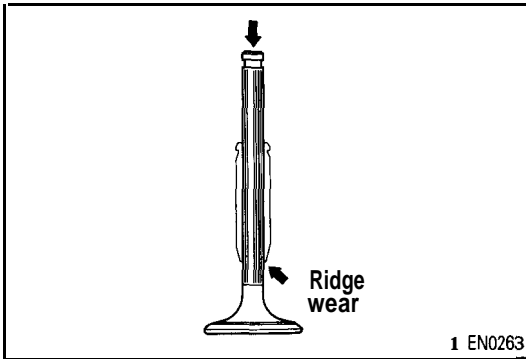

VALVE

- (1) If the valve stem is worn (ridge wear) or otherwise damaged, replace. Also replace the valve if the stem end (that contacts the rocker arm adjusting screw) has a dent.

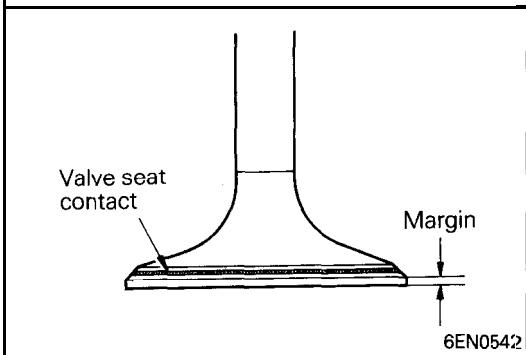

- (2) Check the valve face for correct contact. If incorrect, reface using a valve refacer. Valve should make a uniform contact with the seat at the center of valve face.
- (3) If the margin exceeds the service limit, replace the valve.

Standard value:

Intake 1.2 mm (.047 in.)
Exhaust 2.0 mm (.079 in.)

Limit:

Intake 0.7 mm (.028 in.)
Exhaust 1.5 mm (.059 in.)

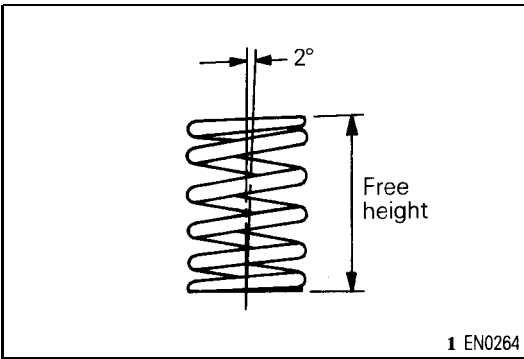

VALVE SPRINGS

- (1) Measure the free height of the spring and, if it is smaller than the limit, replace.

Standard value:

SOHC		49.8 mm (1.961 in.)
DOHC		
up to 1992 models		45.2 mm (1.780 in.)
From 1993 models		46.4 mm (1.827 in.)

Limit:

SOHC		48.8 mm (1.921 in.)
DOHC		
up to 1992 models		44.2 mm (1.740 in.)
From 1993 models		45.4 mm (1.878 in.)

- (2) Measure the squareness of the spring and, if the limit is exceeded, replace.

Standard value: 2°

Limit: 4°

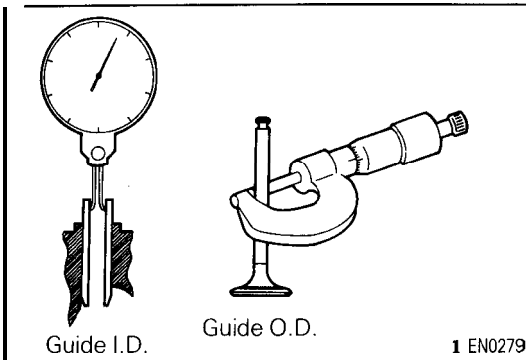

VALVE GUIDES

- (1) Measure the clearance between the valve guide and valve stem. If the limit is exceeded, replace the valve guide or valve, or both.

Standard value:

Intake	0.03 – 0.06 mm (.0012 – .0024 in.)
Exhaust	0.05 – 0.09 mm (.0020 – .0035 in.)

Limit

Intake	0.10 mm (.0039 in.)
Exhaust	0.15 mm (.0059 in.)

VALVE SEAT RECONDITIONING PROCEDURES

- (1) Before valve seat reconditioning, check the valve stem-to-guide clearance.
- (2) Recondition the valve seat with a seat grinder or cutter. The valve seat width should be the specified value at the center of the valve face.

Inspect the valve seat with prussian blue to determine where the valve contacts the seat. To do this, coat the valve seat lightly with prussian blue, and then set the valve in place.

Rotate the valve with a light pressure. If the blue is transferred to the center of the valve face, contact is satisfactory.

If the blue is transferred to the top edge of the valve face, lower the valve seat with a 30 degrees stone or cutter. If the blue is transferred to the bottom edge of the valve face, raise the valve seat with a 65 degrees stone or cutter.

Valve seat diameter:

Intake	44 mm (1.73 in.)
Exhaust	38 mm (1.50 in.)

Seat width: 0.9 – 1.3 mm (.035 – .051 in.)

- (3) The valve and valve seat should be lapped with lapping compound.

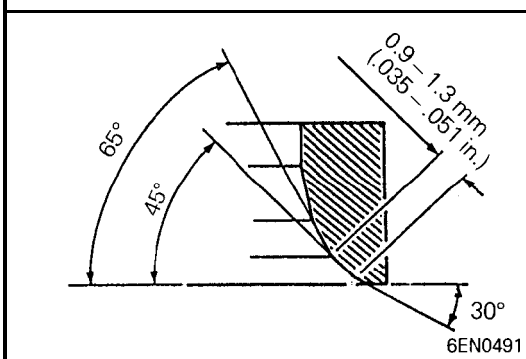

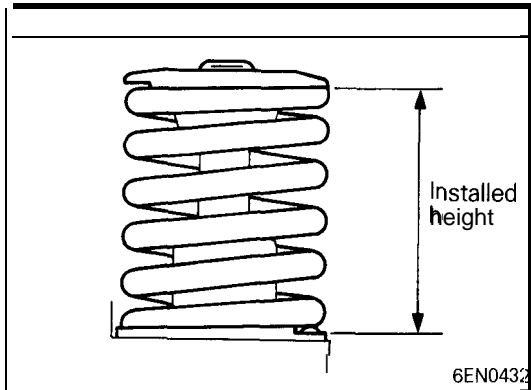

6EN0432

- (4) Check the valve seat sinkage.
 The valve seat sinkage can be determined by measuring the valve spring's installed height. (If the valve seat sinkage is great, the valve seat's installed height also is great.)
 If the valve spring's installed height exceeds the service limit, replace the insert with an oversize part as described below.

Installed height of spring (both intake and exhaust)
Standard value: 40.4 mm (1.591 in.)
Limit: 41.4 mm (1.630 in.)

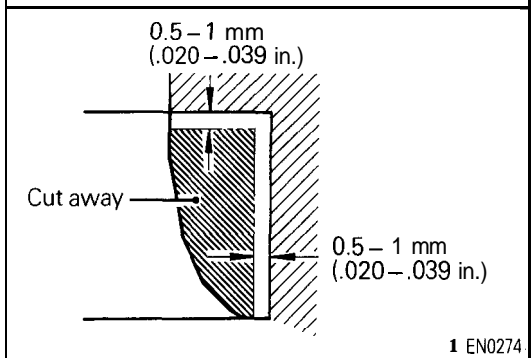

1 EN0274

VALVE SEAT REPLACEMENT PROCEDURE

- (1) Cut the valve seat to be replaced from the inside to thin the wall thickness. Then, remove the valve seat.

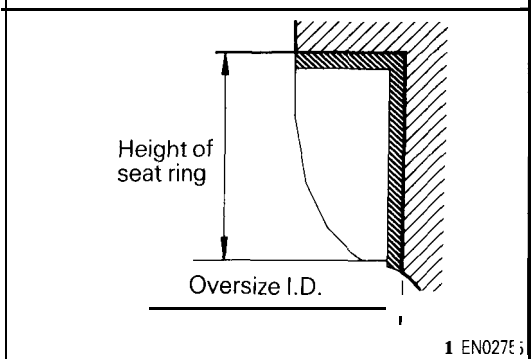

1 EN0275

- (2) Rebore the valve seat hole in the cylinder head to a selected oversize valve seat diameter.

Intake valve seat hole diameter
0.30 O.S.: 44.30 – 44.33 mm (1.7441 – 1.7453 in.)
0.60 O.S.: 44.66 – 44.63 mm (1.7559 – 1.7571 in.)

Exhaust valve seat hole diameter
0.30 O.S.: 38.30 – 38.33 mm (1.5079 – 1.5091 in.)
0.60 O.S.: 38.60 – 38.63 mm (1.5197 – 1.5209 in.)

- (3) Before fitting the valve seat, either heat the cylinder head up to approximately 250°C (482°F) or cool the valve seat in liquid nitrogen, to prevent the cylinder head bore from galling.
 (4) Using a valve seat cutter, correct the valve seat to the specified width and angle.
 See "VALVE SEAT RECONDITIONING PROCEDURE".

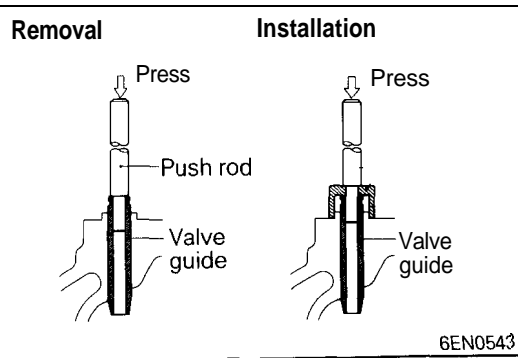

6EN0543

VALVE GUIDE REPLACEMENT PROCEDURE

- (1) Remove the snap ring from the exhaust valve; guide.
 (2) Using the push rod and a press, remove the valve guide toward the cylinder head gasket surface.
 (3) Rebore the valve guide hole to the new oversize valve guide outside diameter.

Valve guide hole diameter
0.05 O.S.: 13.05 – 13.07 mm (.5138 – .5145 in.)
0.25 O.S.: 13.25 – 13.27 mm (.5217 – .5224 in.)
0.50 O.S.: 13.50 – 13.52 mm (.5315 – .5322 in.)

NOTE

Do not install a valve guide of the same size again.

- (4) Using the special tool, press-fit the valve guide, working from the cylinder head top surface.
- (5) After installing valve guides, insert new valves in them to check for sliding condition.
- (6) When valve guides have been replaced, check for valve contact and correct the valve seats as necessary.

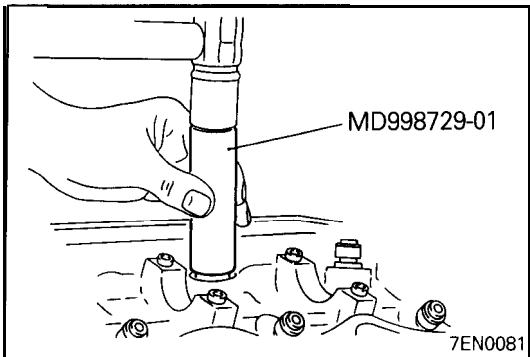
**INSTALLATION SERVICE POINTS****◆A◆ VALVE STEM SEAL INSTALLATION**

- (1) Install the valve spring seat.
- (2) Using the special tool, install a new stem seal to the valve guide.

Caution

Do not reuse removed valve stem seals.

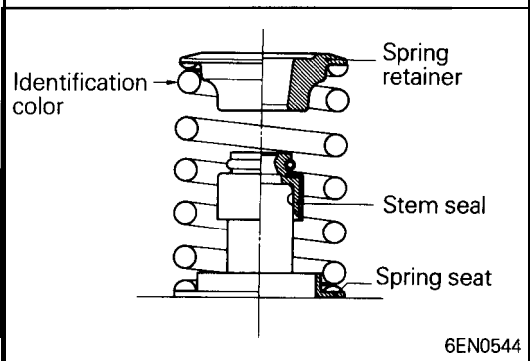
**◆B◆ VALVE SPRING INSTALLATION**

- (1) Direct the valve spring end with identification color toward the spring retainer.

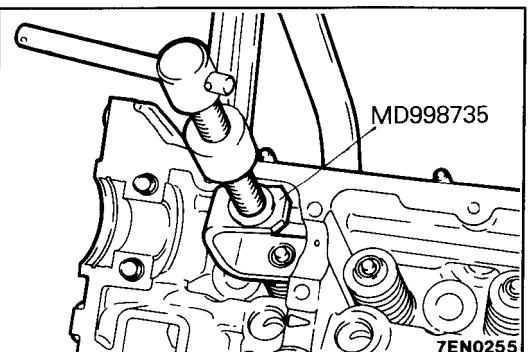
**◆C◆ RETAINER LOCK INSTALLATION**

- (1) Using the special tool, compress the valve spring and insert the retainer lock into position.

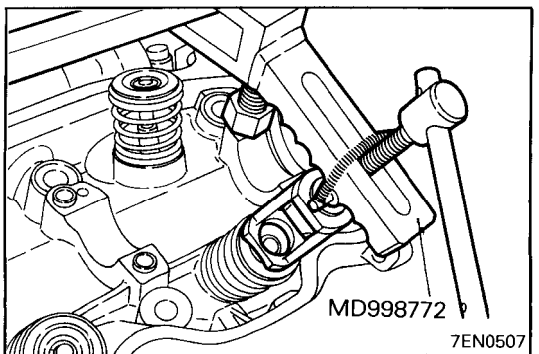

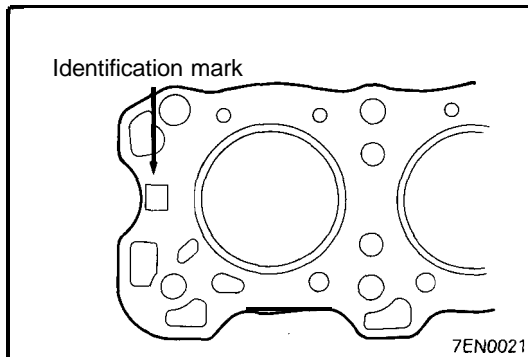
**◆D◆ CYLINDER HEAD GASKET IDENTIFICATION****Caution**

Do not apply sealant to the cylinder head gasket.

Identification mark:

DIAMANTE and MONTERO 72
TRUCK 72W

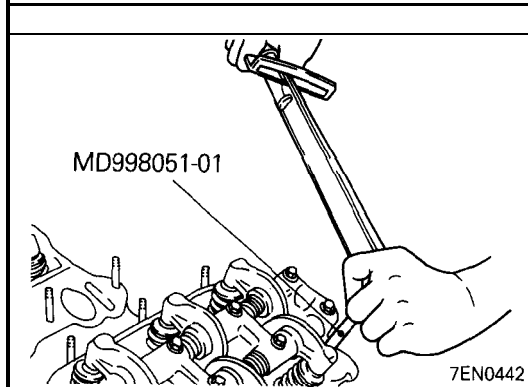
**◆E◆ CYLINDER HEAD BOLT INSTALLATION**

- (1) Tighten the cylinder head bolts in the sequence shown. Each bolt should be tightened in two to three steps, torquing progressively. Tighten to the specified torque in the final sequence.

CYLINDER HEAD AND VALVES – DOHC

REMOVAL OF INSTALLATION

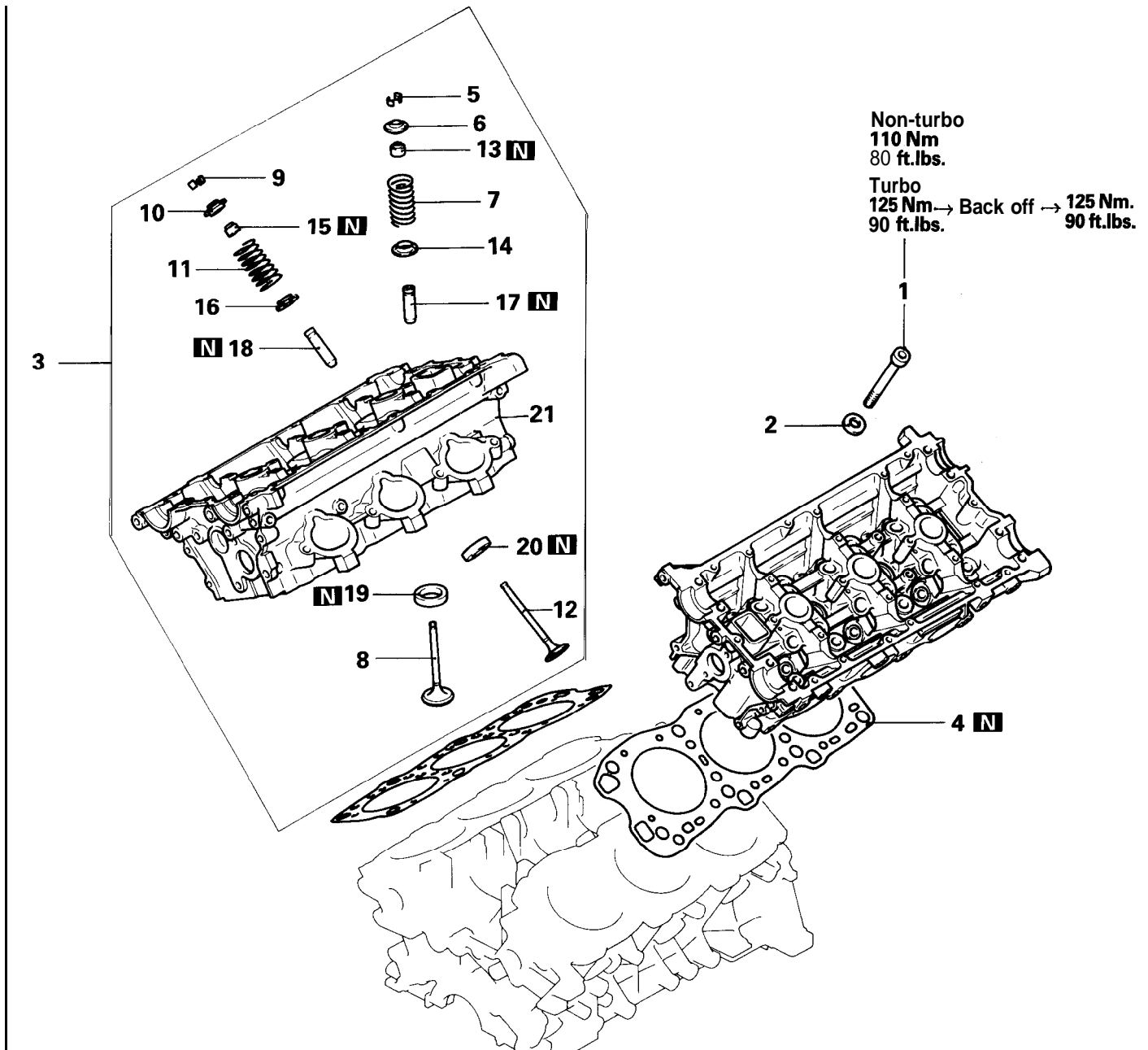

Removal steps

- | | | | |
|---------|---------------------------|---------|-------------------------|
| ↻A↻ ↻E↻ | 1. Cylinder head bolt | ↻B↻ | 11. Valve spring |
| | 2. Washer | | 12. Exhaust valve |
| | 3. Cylinder head assembly | ↻C↻ ↻A↻ | 13. Valve stem seal |
| ↻D↻ | 4. Cylinder head gasket | | 14. Valve spring seat |
| ↻B↻ ↻C↻ | 5. Retainer lock | ↻C↻ ↻A↻ | 15. Valve stem seal |
| | 6. Valve spring retainer | | 16. Valve spring seat |
| ↻B↻ | 7. Valve spring | | 17. Intake valve guide |
| | 8. Intake valve | | 18. Exhaust valve guide |
| ↻B↻ ↻C↻ | 9. Retainer lock | | 19. Intake valve seat |
| | 10. Valve spring retainer | | 20. Exhaust valve seat |
| | | | 21. Cylinder head |

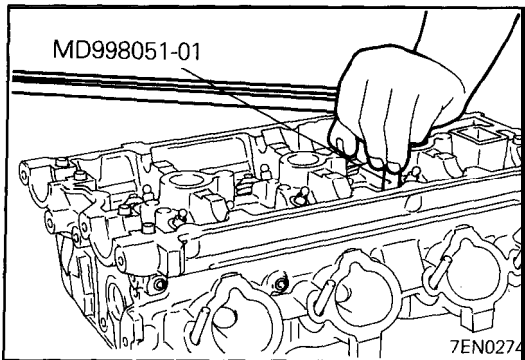
**REMOVAL SERVICE POINTS****◁A▷ CYLINDER HEAD BOLT REMOVAL**

- (1) Using the special tool, loosen the cylinder head bolts.
Loosen evenly, little by little.

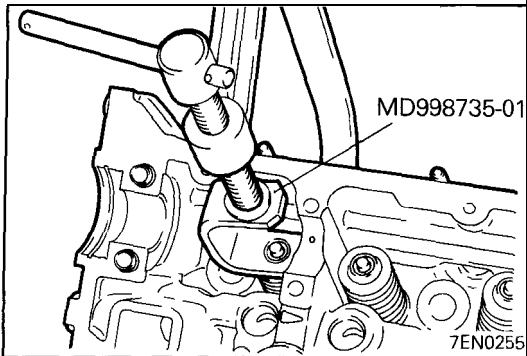
**◁B▷ RETAINER LOCK REMOVAL**

- (1) Using the special tool, compress the spring.
- (2) Remove the retainer locks.

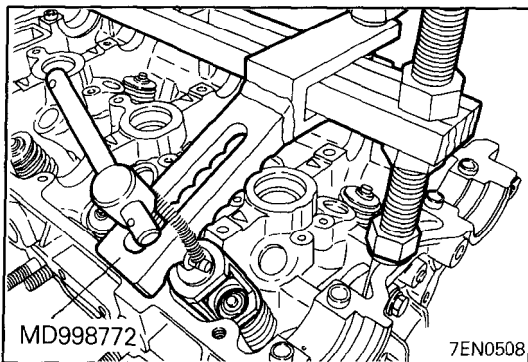
**◁C▷ VALVE STEM SEAL REMOVAL**

- (1) Do not reuse removed stem seals.

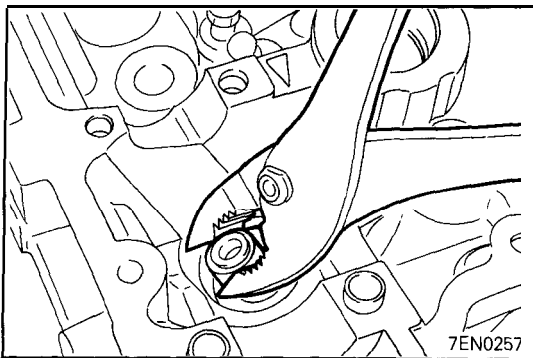
**INSPECTION**

For inspection, only variations from the SOHC engine are described below.
(Refer to page 11 E-93, 94, 95 and 96)

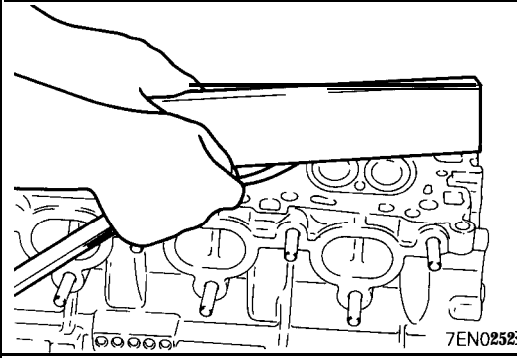
**CYLINDER HEAD**

Cylinder head height (when new):
131.9 – 132.1 mm (5.193 – 5.201 in.)

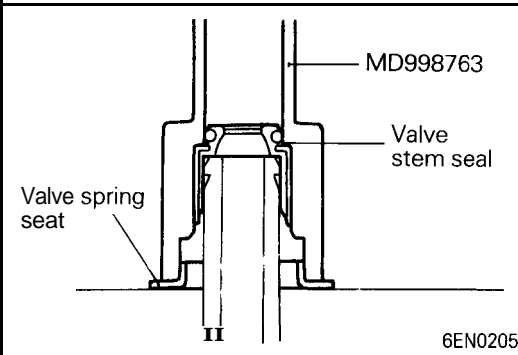
**INSTALLATION SERVICE POINTS****▶▶ VALVE STEM SEAL INSTALLATION**

- (1) Install the valve spring seat.
- (2) Using the special tool, install a new stem seal to the valve guide.

Caution

Do not reuse removed valve stem seal.

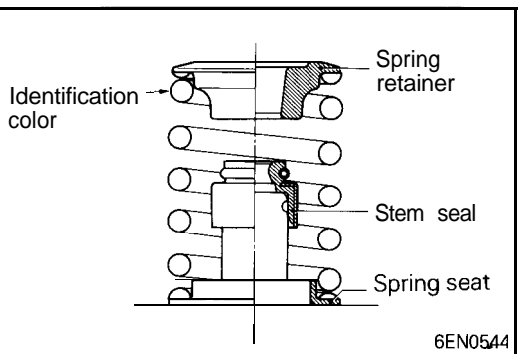
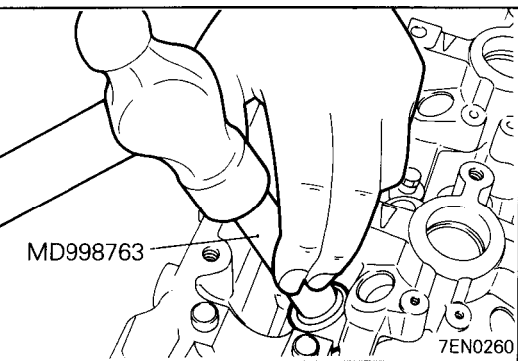
**▶▶ VALVE SPRING INSTALLATION**

- (1) Install the valve spring so that the end with identification color is positioned on the rocker arm end.

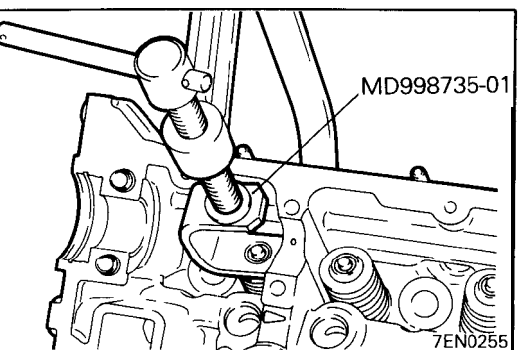
**▶▶ INSTALLATION OF RETAINER LOCKS**

- (1) Using the special tool, compress the valve spring and insert the retainer lock into position.

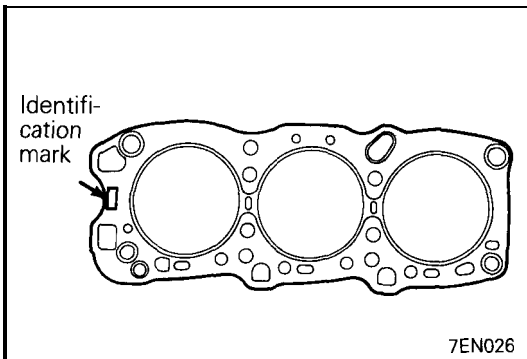
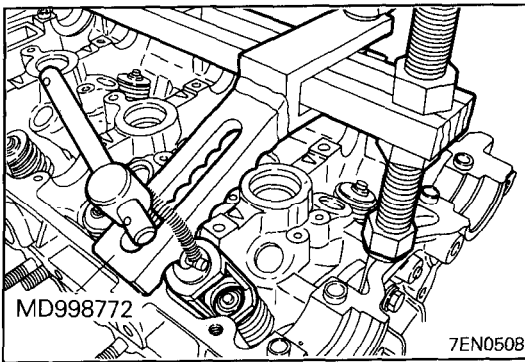

◆D◆ CYLINDER HEAD GASKET IDENTIFICATION

Identification mark	
Non-turbo	2DN
Turbo	2DT

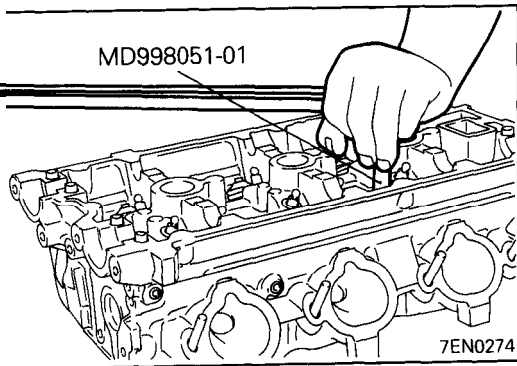

◆E◆ CYLINDER HEAD BOLT INSTALLATION

<Turbo engine>

- (1) Tighten the bolts in two to three stages in the illustrated sequence.
- (2) Back off the bolts once and tighten them to the specified torque in the same procedure as shown in step (1).

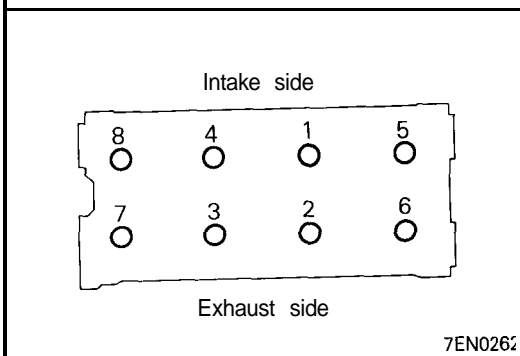

REMOVAL AND INSTALLATION – MONTERO and TRUCK

Bolt with head mark "4" 24 Nm
17 ft.lbs.

Bolt with head mark "7" 14 Nm
10 ft.lbs.

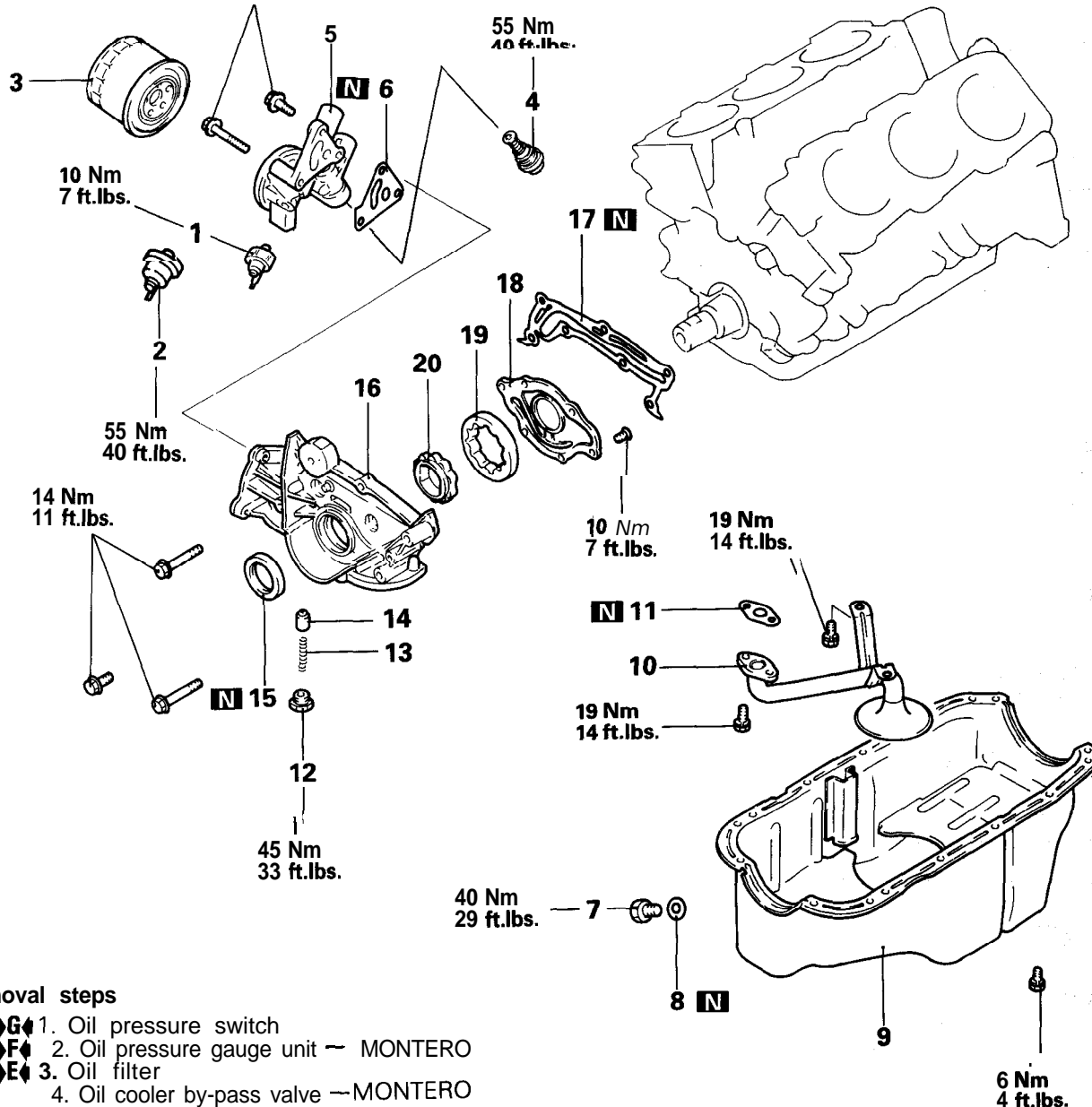

Removal steps

- ◆G◆ 1. Oil pressure switch
- ◆F◆ 2. Oil pressure gauge unit — MONTERO
- ◆E◆ 3. Oil filter
- 4. Oil cooler by-pass valve —MONTERO
- 5. Oil filter bracket
- 6. Oil filter bracket gasket
- 7. Drain plug
- ◆D◆ 8. Drain plug gasket
- ◆A◆ ◆C◆ 9. Oil pan
- 10. Oil screen
- 11. Oil screen gasket
- 12. Plug
- 13. Relief spring
- 14. Relief plunger
- ◆B◆ 15. Crankshaft oil seal
- 16. Oil pump case
- 17. Oil pump gasket
- 18. Oil pump cover
- ◆B◆ ◆A◆ 19. Oil pump outer rotor
- ◆B◆ ◆A◆ 20. Oil pump inner rotor

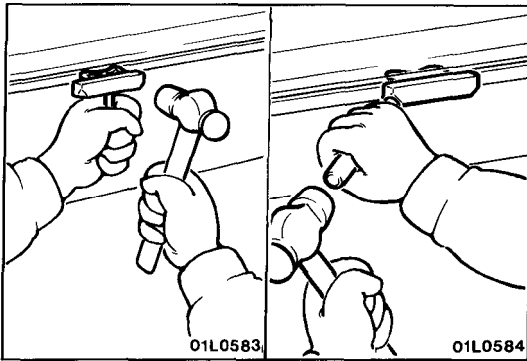
**REMOVAL SERVICE POINT****◊A◊ OIL PAN REMOVAL**

- (1) Knock the special tool deeply between the oil pan and the cylinder block.
- (2) Hitting the special tool on the side, slide it along the oil pan to remove it.

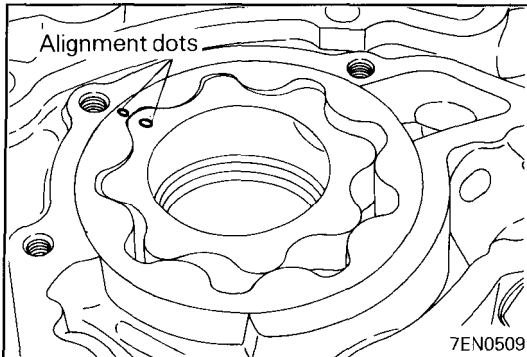
**◊B◊ OUTER ROTOR / INNER ROTOR REMOVAL**

- (1) Make alignment dots on the outer and inner rotors for reference in reassembly.

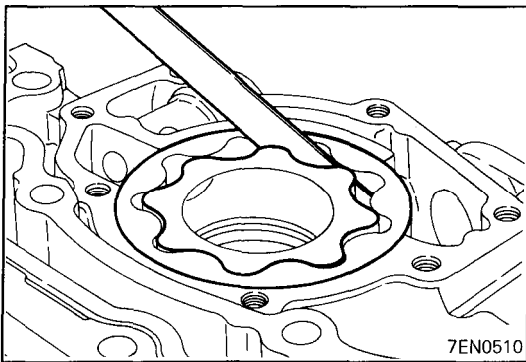
**INSPECTION****OIL PUMP**

- (1) Check the tip clearance.

Standard value: 0.03 – 0.08 mm (.0012 – .0031 in.)

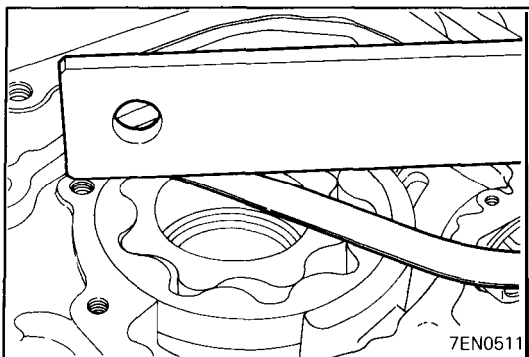

- (2) Check the side clearance.

Standard value: 0.04 – 0.10 mm (.0016 – .0039)

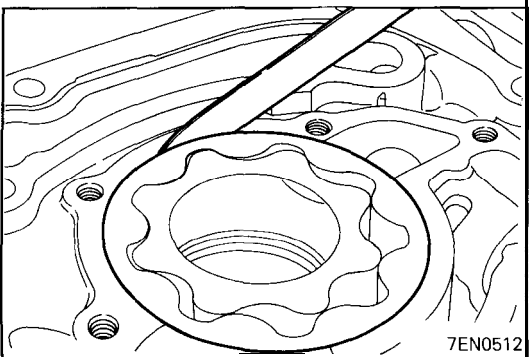

- (3) Check the body clearance.

Standard value: 0.10 – 0.18 mm (.0040 – .0070)

Limit: 0.35 mm (.0138)

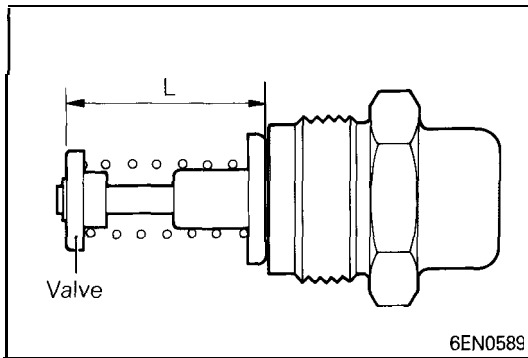
**OIL COOLER BYPASS VALVE**

- (1) Make sure that the valve moves smoothly.
- (2) Ensure that the dimension L measures the standard value under normal temperature and humidity.

Dimension L: 34.5 mm (1.358 in.)

- (3) The dimension must be the standard value when measured after the valve has been dipped in 100°C (212°F) oil.

Dimension L: 40 mm (1.57 in.) or more

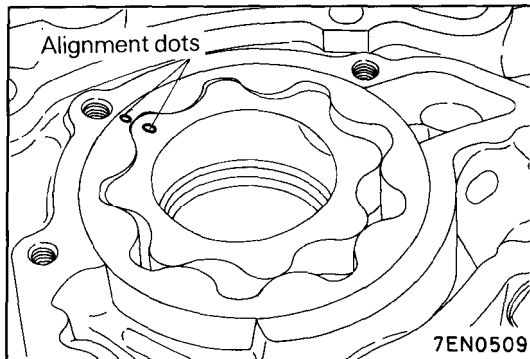
**INSTALLATION SERVICE POINTS****▶A◀ INNER ROTOR / OUTER ROTOR INSTALLATION**

- (1) Apply engine oil to the rotors. Then, install the rotors ensuring that the alignment dots made at disassembly are properly aligned.

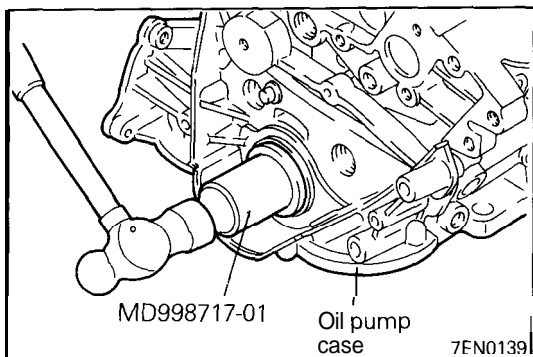
**▶B◀ CRANKSHAFT FRONT OIL SEAL INSTALLATION**

- (1) Using the special tool, knock the oil seal into the oil pump case.

NOTE

Knock it as far as it goes.

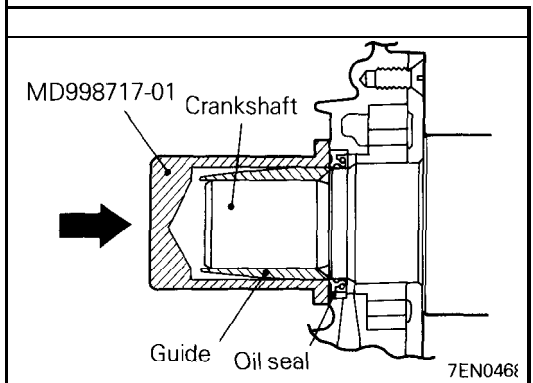

🔧 OIL PAN INSTALLATION

- (1) Remove all the remaining gasket from the mating surfaces using a scraper or a wire brush.
- (2) Apply a 4 mm (.16 in.) diameter bead of sealant to the oil pan flange.
See "Form In-Place Gasket" in introduction.

Specified sealant:

Mitsubishi Genuine Part No. MD970389 or equivalent

- (3) The oil pan should be installed within 15 minutes after the application of sealant.
- (4) Tighten the flange bolts in the sequence shown in the illustration.

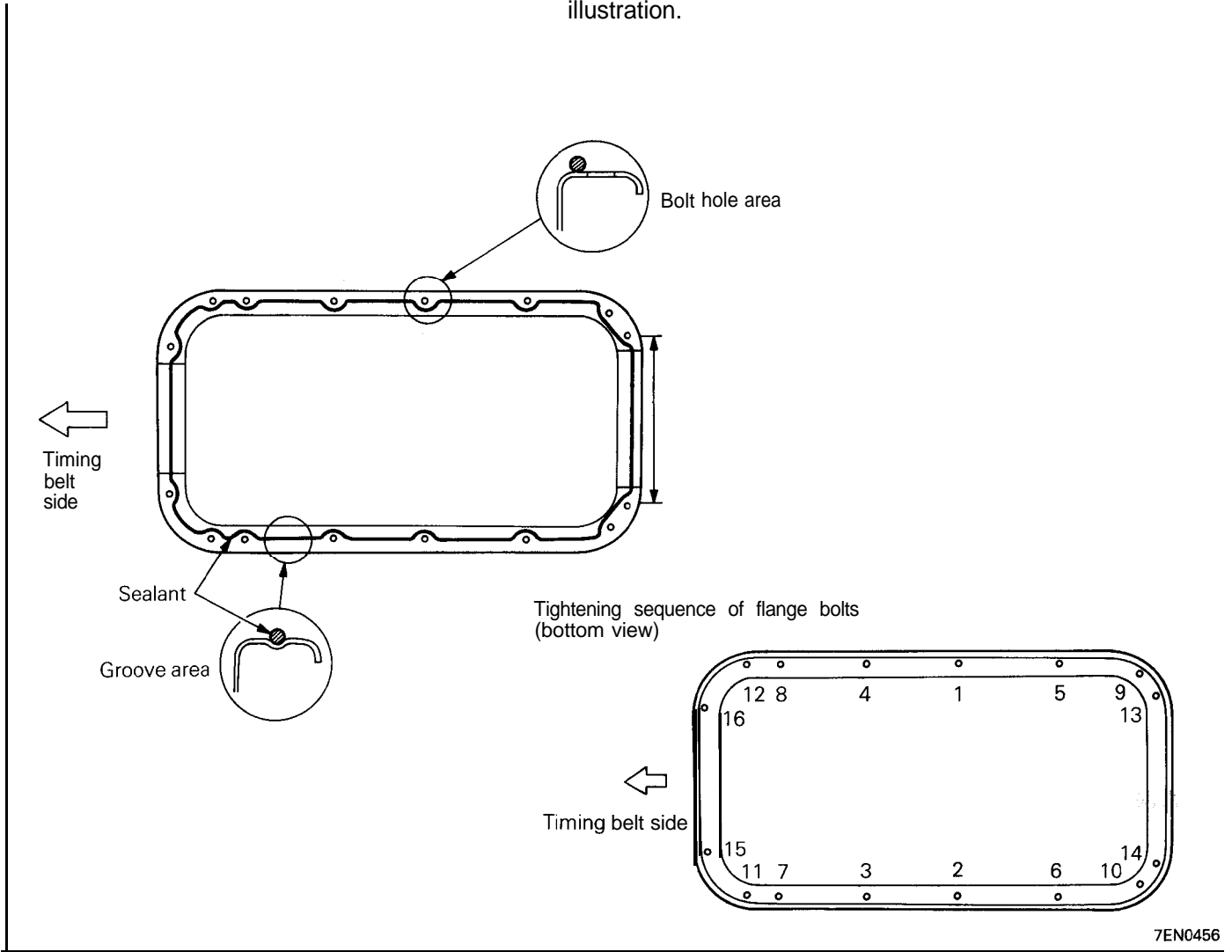

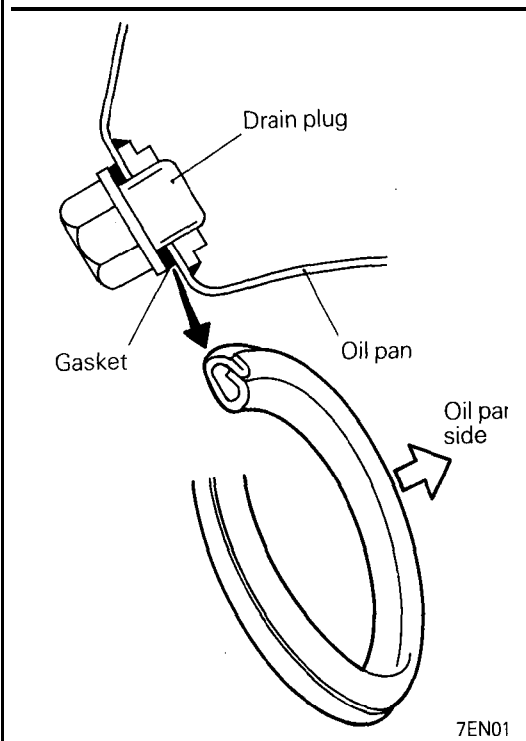

◆◆ DRAIN PLUG GASKET INSTALLATION

- (1) Install the drain plug gasket as illustrated.

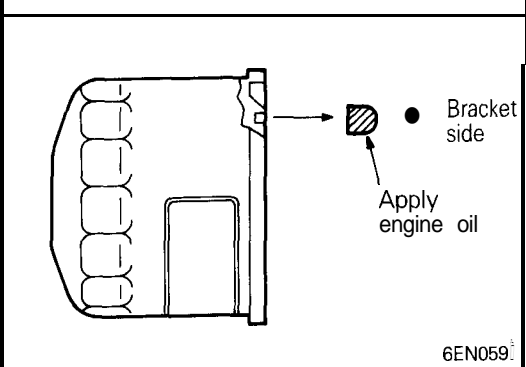

◆◆ OIL FILTER INSTALLATION

- (1) Clean the installation surface of the filter bracket.
- (2) Apply engine oil to the O-ring of the oil filter.
- (3) Screw the oil filter on until the O-ring contacts the bracket. Then tighten 3/4 turn.

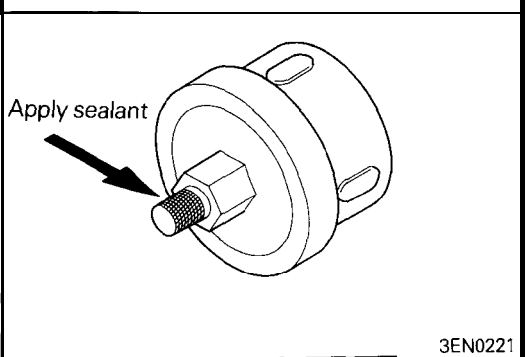

◆◆ SEALANT APPLICATION TO OIL PRESSURE GAUGE UNIT

- (1) Coat the threads of the gauge unit with sealant and install it using the special tool.

Specified sealant:

3M ATD Part No.8660 or equivalent

Caution

1. Keep the end of threaded portion clear of sealant.
2. Avoid an overtightening.

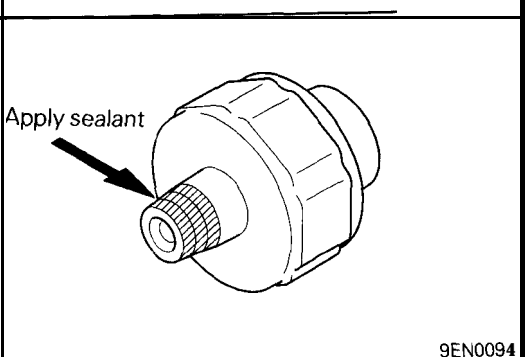

◆◆ SEALANT APPLICATION TO OIL PRESSURE SWITCH

- (1) Coat the threads of the switch with sealant and install the switch using the special tool.

Specified sealant:

3M ATD Part No.8660 or equivalent

Caution

1. Keep the end of threaded portion clear of sealant.
2. Avoid an overtightening.

PISTON AND CONNECTING ROD

REMOVAL AND INSTALLATION

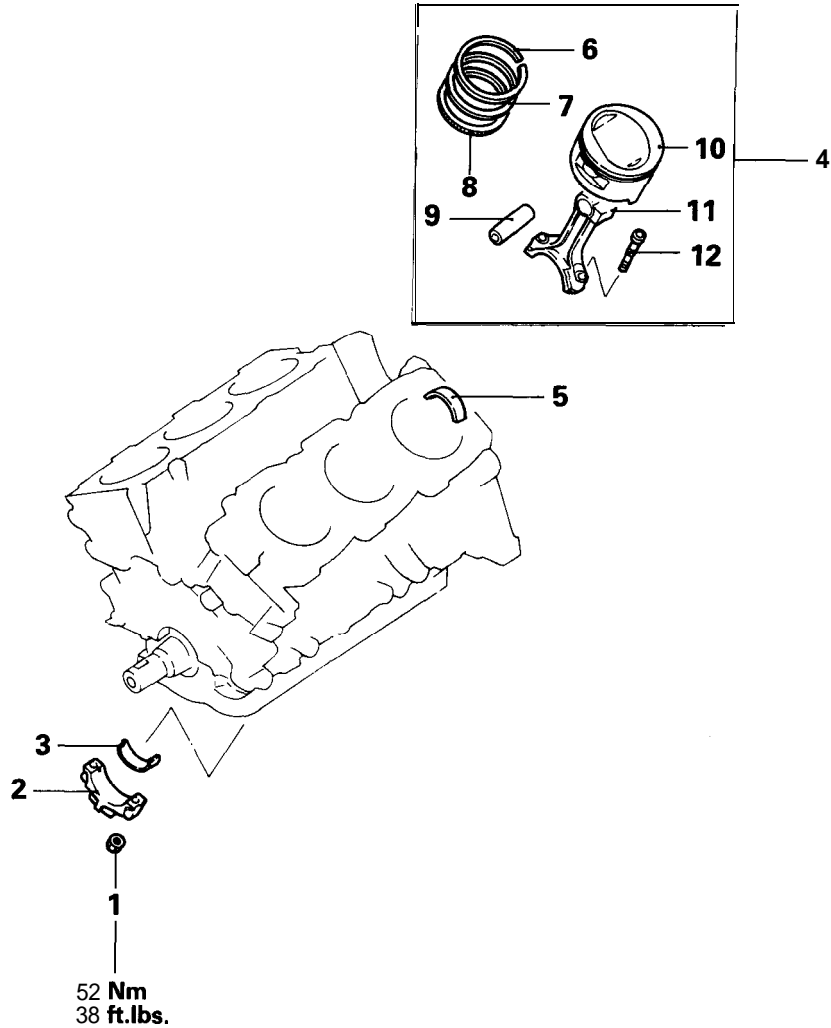

Removal steps

1. Nut
- ↔A↔ ↔E↔ 2. Connecting rod cap
3. Connecting rod bearing (lower)
- ↔D↔ 4. Piston, connecting rod assembly
5. Connecting rod bearing (upper)
- ↔C↔ 6. Piston ring No.1
- ↔C↔ 7. Piston ring No.2
- ↔B↔ 8. Oil ring
- ↔B↔ ↔A↔ 9. Piston pin
10. Piston
11. Connecting rod
12. Bolt

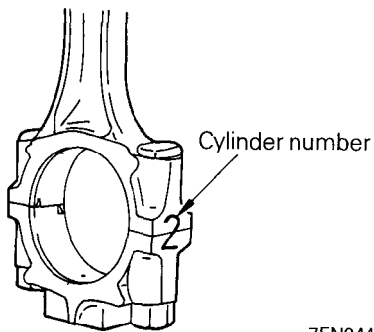

7EN044E

REMOVAL SERVICE POINTS

◀A▶ CONNECTING ROD CAP REMOVAL

- (1) Mark the cylinder number, on the side of the connecting rod big end for correct reassembly.
- (2) Keep the removed connecting rods, caps, and bearings in order according to the cylinder number..

Piston pin setting tool MIT21 6941

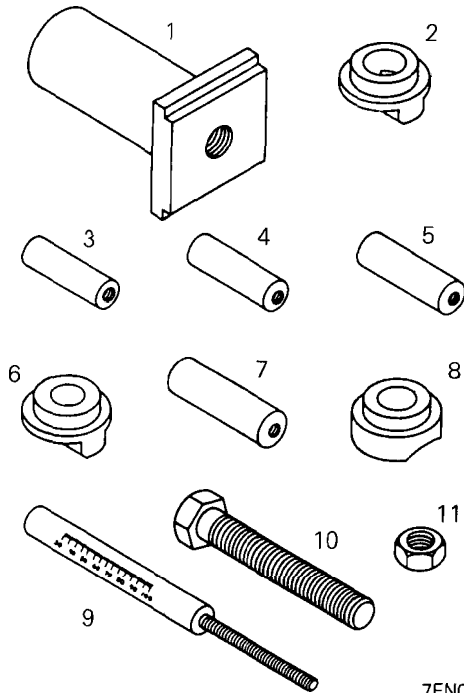

7EN042E

◀B▶ PISTON PIN REMOVAL

Item No.	Part No.	Description
1	MIT310134	Base
2	MIT310136	Piston Support
3	MIT310137	Connecting Rod Guide Pin
4	MIT310138	Connecting Rod Guide Pin
5	MIT310139	Connecting Rod Guide Pin
6	MIT310140	Piston Support
7	MIT310141	Connecting Rod Guide Pin
8	MIT310142	Piston Support
9	MIT48143	Press Pin
10	216943	Stop Screw
11	10396	Nut

- (1) Remove the stop screw from the base.
- (2) Select the correct piston support for your application. (See above) Fit the piston support onto the base. Place the base on the press support blocks.
- (3) Insert the press pin through the piston pin hole. Select the correct connecting rod guide pin. (See above.) Thread the guide pin onto the threaded portion of the press pin.
- (4) Position the piston assembly on the piston support in the press. With the press pin up as shown in the illustration, insert the guide pin through the hole in the piston and through the hole in the piston support.
- (5) Press the piston pin out of the assembly.

IMPORTANT: To avoid piston damage,

- **The piston support must seat squarely against the piston.**
- **Verify that the piston pin will slide through the hole in the piston support.**

- (6) Remove the piston pin from the piston pin.

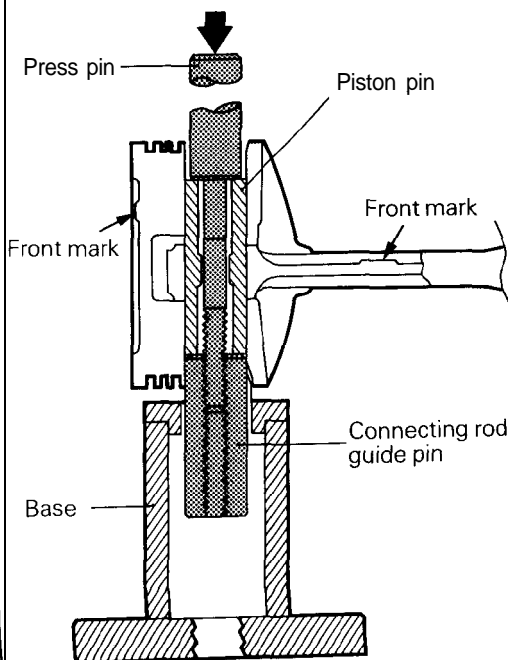

7EN042E

INSPECTION**PISTON**

- (1) Replace the piston if scratches or seizure is evident on its surfaces (especially the thrust surface). Replace the piston if it is cracked.

PISTON PIN

- (1) Insert the piston pin into the piston pin hole with a thumb. You should feel a slight resistance. Replace the piston pin if it can be easily inserted or there is an excessive play.
- (2) The piston and piston pin must be replaced as an assembly.

PISTON RING

- (1) Check the piston ring for damage, excessive wear, and breakage and replace if defects are evident. If the piston has been replaced with a new one, the piston rings must also be replaced with new ones.
- (2) Check for clearance between the piston ring and ring groove. If the limit is exceeded, replace the ring or piston, or both.

Standard value:**No. 1****DIAMANTE and 3000GT**

0.03 – 0.07 mm (.0012 – .0026 in.)

MONTERO and TRUCK

0.05 – 0.09 mm (.0020 – .0035 in.)

No. 2

0.02 – 0.06 mm (.0008 – .0024 in.)

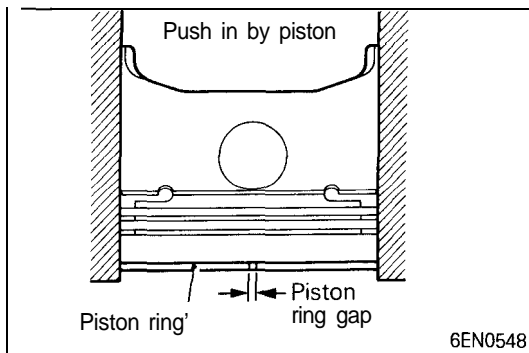
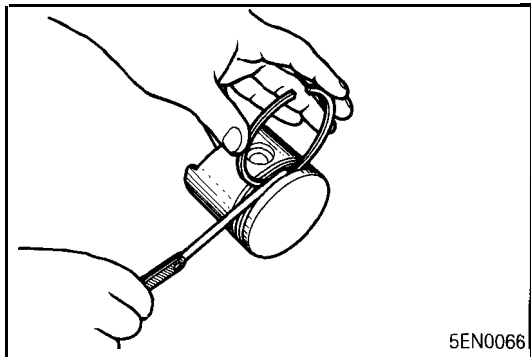
Limit: 0.1 mm (.004 in.)

- (3) Insert the piston ring into the cylinder bore. Force the ring down with a piston, the piston crown being in contact with the ring, to correctly position it at right angles to the cylinder wall. Then, measure the end gap with a feeler gauge. If the ring gap is excessive, replace the piston ring.

Standard value:**No. 1**

0.30 – 0.45 mm (.0118 – .0177 in.)

No. 2**DIAMANTE and 3000GT**

0.45 – 0.60 mm (.0177 – .0236 in.)

MONTERO and TRUCK

0.25 – 0.45 mm (.0098 – .0177 in.)

Oil**DIAMANTE and 3000GT**

0.20 – 0.60 mm (.0079 – .0236 in.)

MONTERO and TRUCK

0.20 – 0.70 (.0079 – .0276 in.)

Limit:**No. 1, No. 2 0.8 mm (.031 in.)****Oil 1.0 mm (.039 in.)**

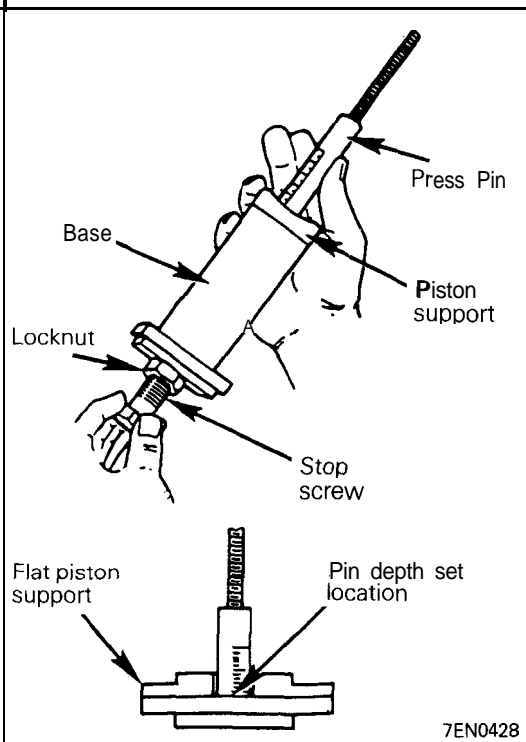
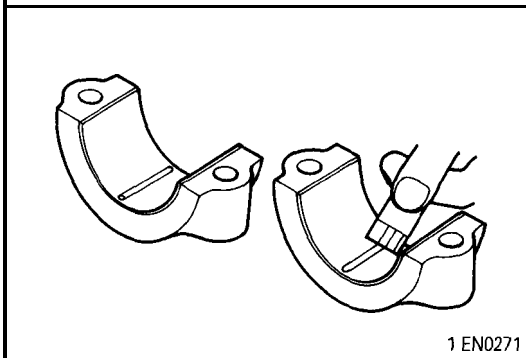
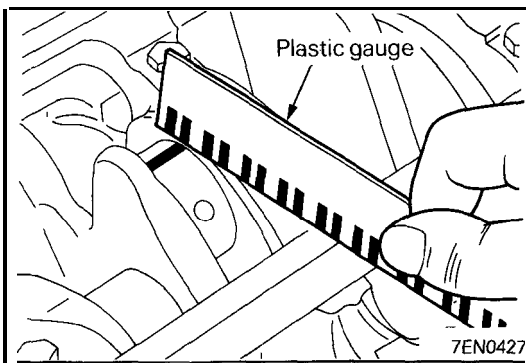

CRANKSHAFT PIN OIL CLEARANCE (PLASTIC GAUGE METHOD)

The crankshaft oil clearance can be measured easily by using a plastic gauge, as follows:

- (1) Remove oil and grease and any other foreign matters from the crankshaft pin and the bearing inner surface.
- (2) Install the crankshaft.
- (3) Cut the plastic gauge to the same length as the width of the bearing and place it on the pin in parallel with its axis.
- (4) Gently place the crankshaft bearing cap over it and tighten the bolts to the specified torque.
- (5) Remove the bolts and gently remove the crankshaft bearing cap.
- (6) Measure the width of the smashed plastic gauge at its widest section by using a scale printed on the plastic gauge bag.

Standard value: 0.02 – 0.05 mm (.0008 – .0020 in.)
Limit: 0.1 mm (.004 in.)

INSTALLATION SERVICE POINTS

◆A◆ PISTON PIN INSTALLATION

- (1) Thread the stop screw and lock nut assembly into the base. Fit the correct piston support on the top of the base. Insert the press pin, threaded end up, into the hole in the piston support until the press pin touches the stop screw.
- (2) Using the graduations on the press pin, adjust the stop screw to the depth.

Depth: MONTERO and TRUCK 60 mm
DIAMANTE, 3000GT 62 mm

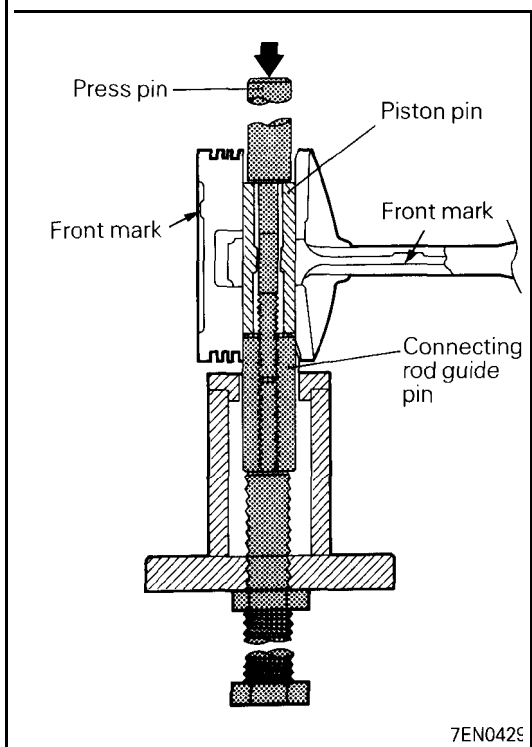

- (3) Place the base on the press support blocks.
- (4) Slide the piston pin over the threaded end of the press pin, and thread the correct guide pin up against it.
- (5) Coat the piston pin with oil, and with the connecting rod held in position, slide the guide pin through the piston and connecting rod.
- (6) Press the piston pin through the connecting rod until the guide pin contacts the stop screw.
- (7) Remove the piston assembly from the base. Remove the guide pin and press pin from the assembly.

IMPORTANT: Due to production tolerance variations, it is necessary to visually inspect the piston pin depth after installation to verify that the piston pin is centered. Adjust if necessary.

▶B◀ OIL RING INSTALLATION

- (1) Fit the oil ring spacer into the piston ring groove.

NOTE

The side rails and spacer may be installed in either direction.

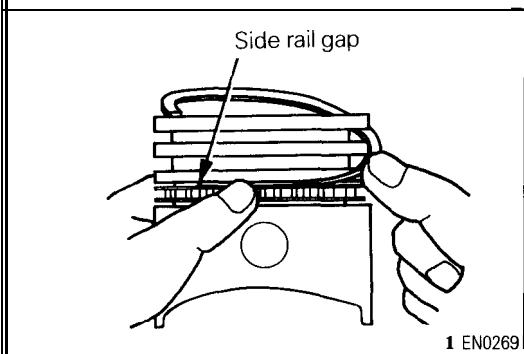
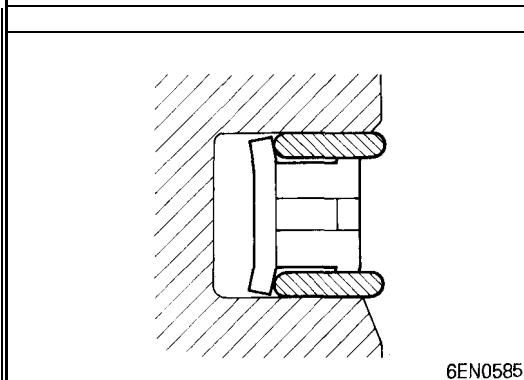

- (2) Install the upper side rail
To install the side rail, first fit one end of the rail into the piston groove, then press the remaining portion into the position by finger. See illustration.
Use of a ring expander to expand the side rail end gap can break the side rail, unlike other piston rings.
- NOTE
Do not use any piston ring expander when installing the side rail.
- (3) Install the lower side rail in the same procedure as described in step (2).
- (4) Make sure that the side rails move smoothly in either direction.

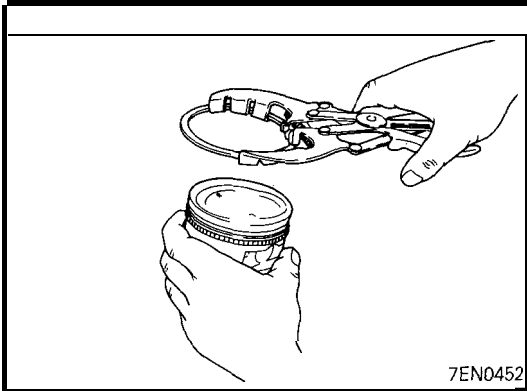

7EN0452

◆C◆ PISTON RING NO.2/ PISTON RING NO.1 INSTALLATION

- (1) Using a piston ring expander, fit No.2 and then No.1 piston ring into position.

NOTE

1. Note the difference in shape between No.1 and No.2 piston rings.
2. Install piston rings No.1 and No.2 with their side having marks facing up (on the piston crown side.)

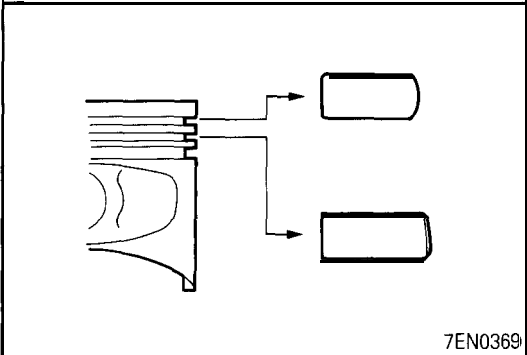

7EN0369

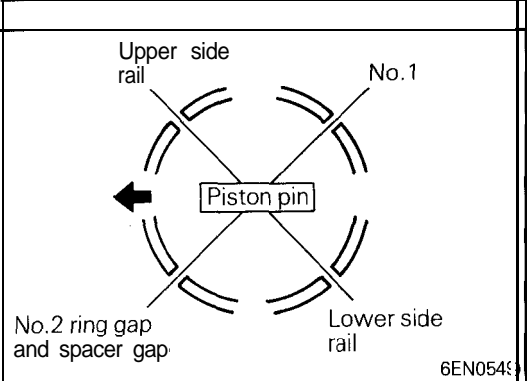

6EN0549

◆D◆ PISTON AND CONNECTING ROD INSTALLATION

- (1) Liberally coat the circumference of the piston, piston ring, and oil ring with engine oil.
- (2) Arrange the piston ring and oil ring gaps (side rail and spacer) as shown in the illustration.
- (3) Rotate the crankshaft so that the crank pin is on the center of the cylinder bore.

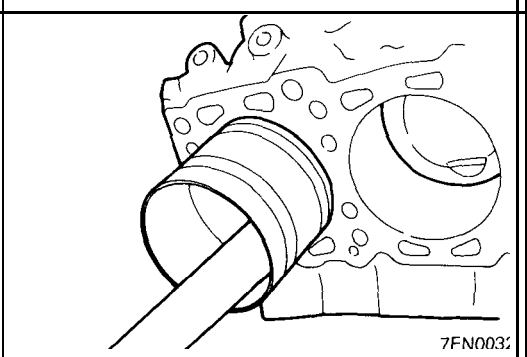

7FN0032

- (4) Use suitable thread protectors on the connecting rod bolts before inserting the piston and connecting rod assembly into the cylinder block. Care must be taken not to nick the crank pin.
- (5) Using a suitable piston ring compressor tool, install the piston and connecting rod assembly into the cylinder block.

Caution

Install the piston with the front mark (arrow mark) on the top of the piston directed towards the engine front (timing belt side).

NOTE

For MONTERO and TRUCK, two types of pistons, one for cylinders 1, 3 and 5 and the other for cylinders 2, 4 and 6, have been used.

Piston with R: For cylinders 1, 3 and 5

Piston with L: For cylinders 2, 4 and 6

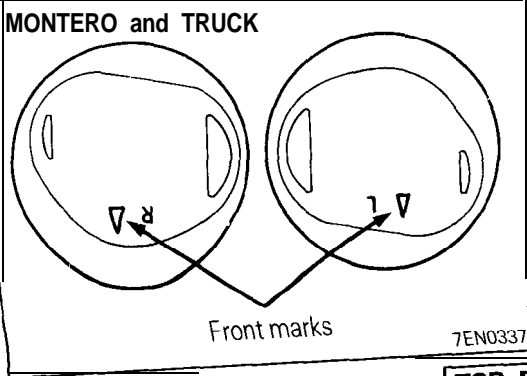

7EN0337

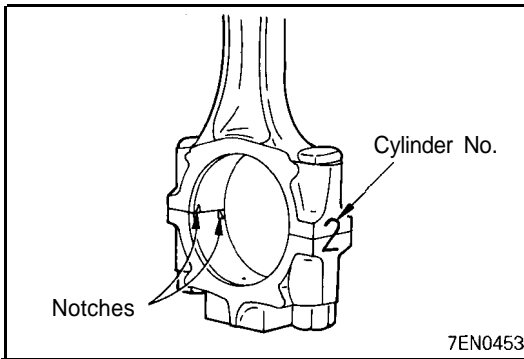

▶E◀ CONNECTING ROD CAP INSTALLATION

- (1) Mate the correct bearing cap with the correct connecting rod by checking with the alignment marks marked during disassembly. If a new connecting rod is used which has no alignment mark, position the notches for locking the bearing on the same side.

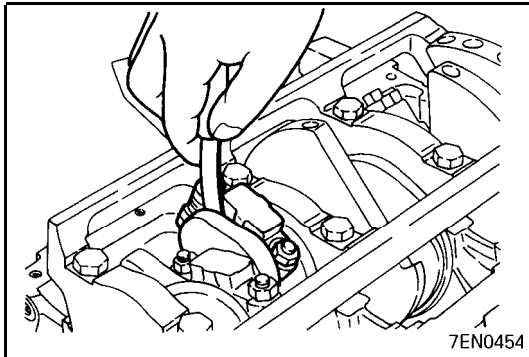

- (2) Check if the thrust clearance in the connecting rod big end is correct.

Standard value: 0.10 – 0.25 mm (.0039 – .0098 in.)
Limit: 0.4 mm (.0157 in.)

CRANKSHAFT, FLYWHEEL AND DRIVE PLATE

REMOVAL AND INSTALLATION

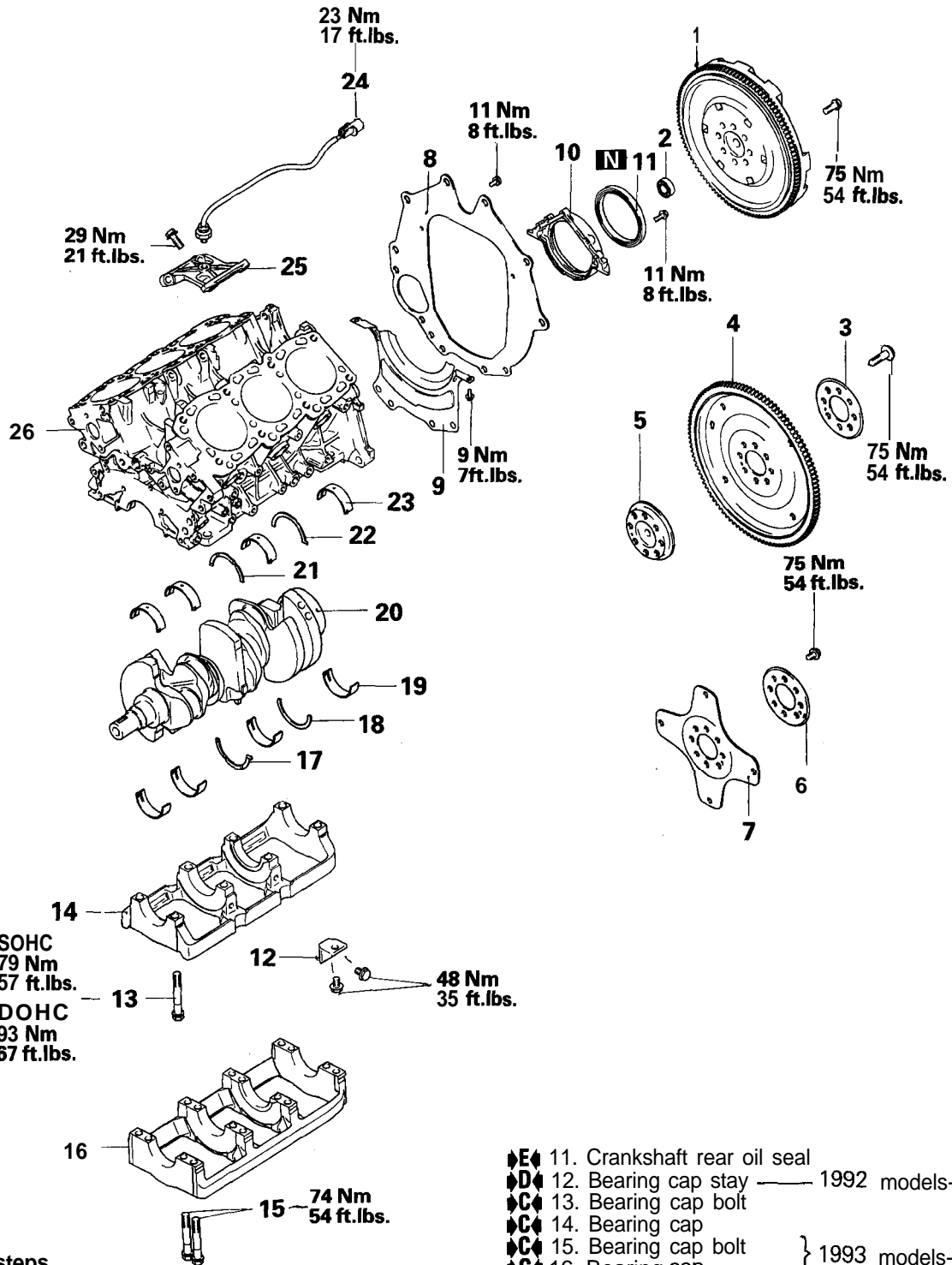

Removal steps

- 1. Flywheel
 - 2. Ball bearing
 - 3. Adaptor plate
 - 4. Drive plate
 - 5. Crankshaft adaptor
 - 6. Adaptor plate
 - 7. Drive plate
 - 8. Rear plate
 - 9. Bell housing cover
 - 10. Oil seal case
- For MIT
- For 4WD A/T
- For FWD A/T

- 11. Crankshaft rear oil seal
 - 12. Bearing cap stay — 1992 models-Turbo
 - 13. Bearing cap bolt
 - 14. Bearing cap
 - 15. Bearing cap bolt
 - 16. Bearing cap
 - 17. Thrust bearing A
 - 18. Thrust bearing B
 - 19. Crankshaft bearing (lower)
 - 20. Crankshaft
 - 21. Thrust bearing B
 - 22. Thrust bearing A
 - 23. Crankshaft bearing (upper)
 - 24. Knock sensor
 - 25. Knock sensor bracket
 - 26. Cylinder block
- } 1993 models-Turbo

INSPECTION**CRANKSHAFT**

If the oil clearance exceeds the limit, replace the bearing, and crankshaft if necessary.

- (1) Measure the outside diameter of the journals and the inside diameter of the crankshaft bearings. If the difference between them (oil clearance) exceeds the limit, replace the crankshaft bearing and, if necessary, crankshaft.

Standard value: 0.02 – 0.05 mm (.0008 – .0020 in.)

Limit: 0.1 mm (.004 in.)

Caution

Do not attempt an undersize machining of the crankshaft with special surface treatment. This crankshaft can be identified by its dull gray appearance.

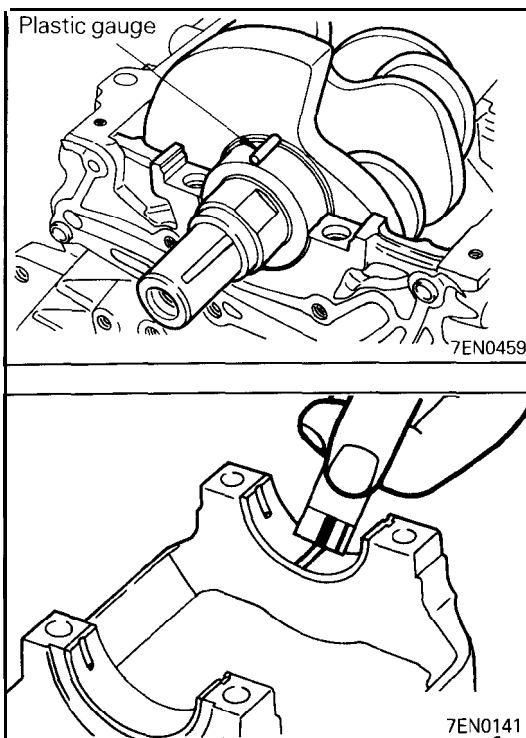
**CRANKSHAFT JOURNAL OIL CLEARANCE (PLASTIC GAUGE METHOD)**

The crankshaft oil clearance can be measured easily by using a plastic gauge, as follows:

- (1) Remove oil and grease and any other foreign matters from the crankshaft journal and bearing inner surface.
- (2) Install the crankshaft.
- (3) Cut the plastic gauge to the same length as the width of the bearing and place it on the journal in parallel with its axis.
- (4) Gently place the crankshaft bearing cap over it and tighten the bolts to the specified torque.
- (5) Remove the bolts and gently remove the crankshaft bearing cap.
- (6) Measure the width of the smashed plastic gauge at its widest section by using a scale printed on the plastic gauge bag.

CRANKSHAFT REAR OIL SEAL

- (1) Check the oil seal lip for wear and damage.
- (2) Check rubber for deterioration or hardening.
- (3) Check the oil seal case for cracks and damage.

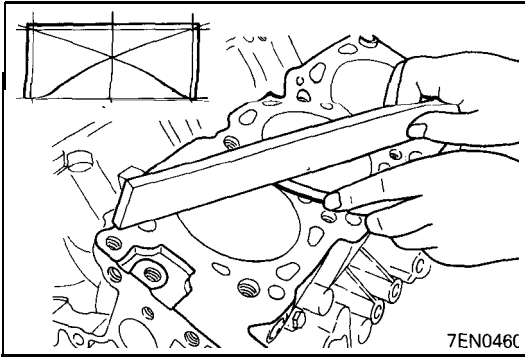

INSPECTION

CYLINDER BLOCK

- (1) Visually check for scratches, rust, and corrosion. Use also a flaw detecting agent for the check. If defects are evident, correct, or replace.
- (2) Using a straightedge and feeler gauge, check the block top surface for warpage. Make sure that the surface is free from gasket chips and other foreign matter.

Standard value: 0.05 mm (.0020 in.)

Limit: 0.1 mm (.0039 in.)

- (3) If the distortion is excessive, correct within the allowable limit or replace.

Grinding limit: 0.2 mm (.008 in.)

The total thickness of the stock allowed to be removed from cylinder block and mating cylinder head is 0.2 mm (.008 in.) at maximum.

Cylinder block height (when new): 210.5 mm (8.29 in.)

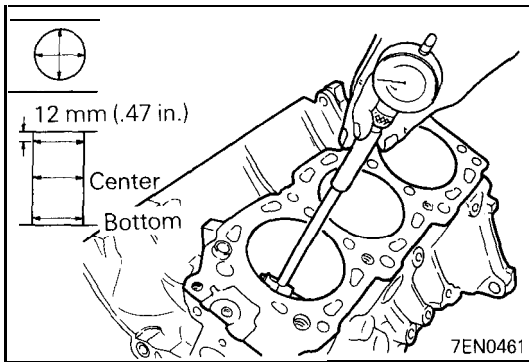

- (4) Check the cylinder walls for scratches and seizure. If defects are evident, correct (rebore to an oversize) or replace.
- (5) Using a cylinder gauge, measure the cylinder bore and cylindricity. If worn badly, correct by boring the cylinders to an oversize and replace pistons and piston rings. Measure at the points shown in the illustration.

Standard value:

Cylinder I.D.: 91.10 – 91.13 mm (3.5866 – 3.5878 in.)

Cylindricity: 0.01 (.0004 in.)

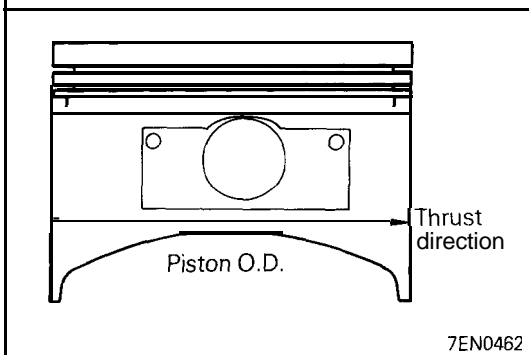

BORING CYLINDER

- (1) Oversize pistons to be used should be determined on the basis of the largest bore cylinder.

Piston size identification

Size	Identification mark
0.25 mm (.01 in.) O.S.	0.25
0.50 mm (.02 in.) O.S.	0.50
0.75 mm (.03 in.) O.S.	0.75
1.00 mm (.04 in.) O.S.	1.00

NOTE

Size mark is stamped on the piston top.

- (2) Measure the outside diameter of the piston to be used. Measure it in the thrust direction as shown.
- (3) Based on the measured piston O.D., calculate the boring finish dimension.

Boring finish dimension = Piston O.D. + (clearance between piston O.D. and cylinder) – 0.02 mm (.0008 in.) (honing margin)

- (4) Bore all cylinders to the calculated boring finish dimension.

Caution

To prevent distortion that may result from temperature rise during honing, bore cylinders in the order of **No.2, No.4, No.6, No.1, No.3** and **No.5**.

- (5) Hone to the final finish dimension (piston O.D. + clearance between piston O.D. and cylinder).
(6) Check the clearance between the piston and cylinder.

Clearance between piston and cylinder:

0.01 – 0.04 mm (.0004 – .0016 in.)

NOTE

When boring cylinders, finish all of six cylinders to the same oversize. Do not bore only one cylinder to an oversize.

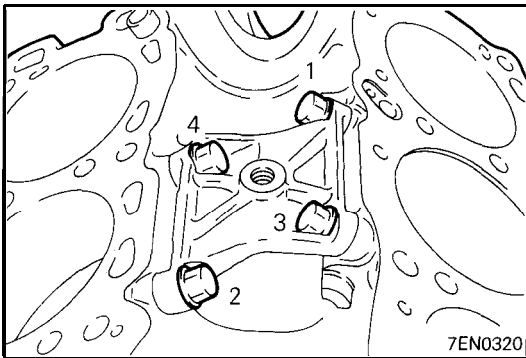

INSTALLATION SERVICE POINTS

◆◆ DETONATION SENSOR BRACKET INSTALLATION

- (1) Check that the bracket is in intimate contact with the cylinder block boss and tighten to specified torque in the order shown.

**▶B▶ CRANKSHAFT BEARING (UPPER) /
THRUST BEARING A / THRUST BEARING B /
CRANKSHAFT BEARING (LOWER) INSTALLATION**

- (1) Classify the crankshaft bearings (upper and lower) by whether there is an oil groove or not. Then, assemble as shown in the illustration.
- (2) Assemble the thrust bearings (A and B) on the No.3 journal area as shown.

Caution

Install them with the groove side facing outward.

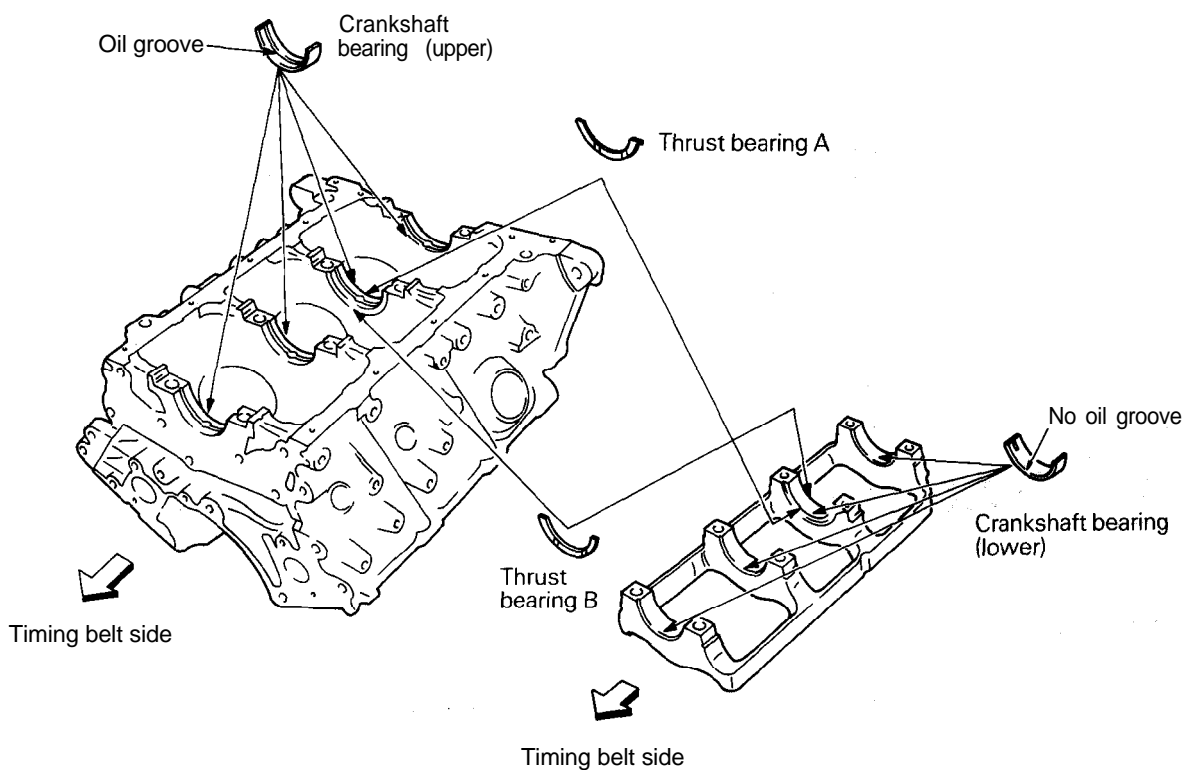

7EN0463

BEARING CAP / BEARING BOLT INSTALLATION

- (1) Attach the bearing cap on the cylinder block as shown in the illustration.
- (2) Tighten the bearing cap bolts to the specified torque in the sequence shown in the illustration.
- (3) Check that the crankshaft rotates smoothly.

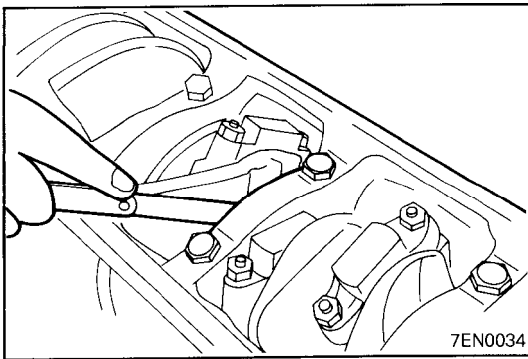
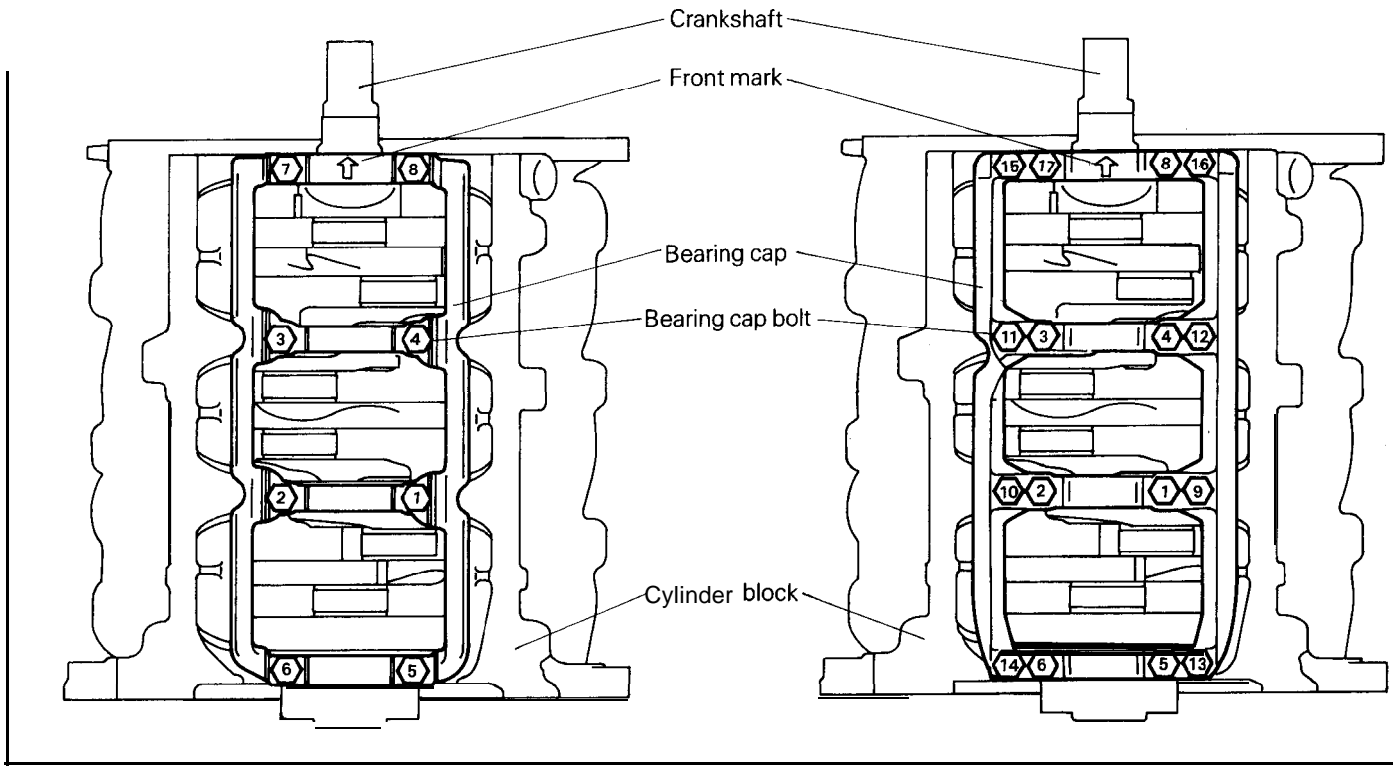

- (4) Check the end plate. If it exceeds the limit value, replace the thrust bearing.

Standard value : 0.05 – 0.25 mm (.0020 – .0098 in.)
Limit: 0.3 mm (.012 in.)

BEARING CAP STAY INSTALLATION – DOHC TURBO

- (1) Apply engine oil to the thread and bearing surface of each bolt.
- (2) Temporarily tighten the bolts on the cylinder block side.
- (3) Tighten the bolts on the bearing cap side to the specified torque.
- (4) Finally, tighten the bolts on the cylinder block side to the specified torque.

NOTE

The bearing cap stays A and B differ in shape. Install correct ones on correct sides.

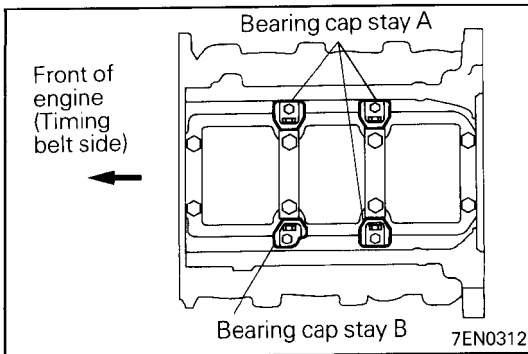

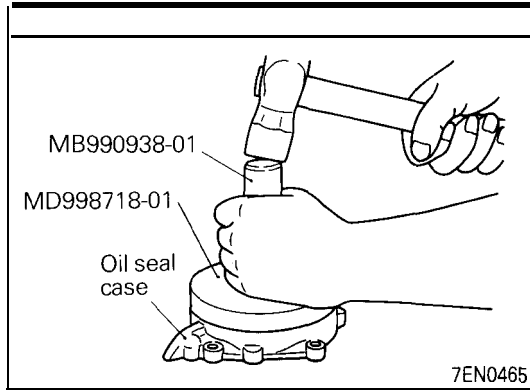

◆E◆ CRANKSHAFT REAR OIL SEAL INSTALLATION

- (1) Using the special tool, press-fit a new crankshaft rear oil seal into the oil seal case.

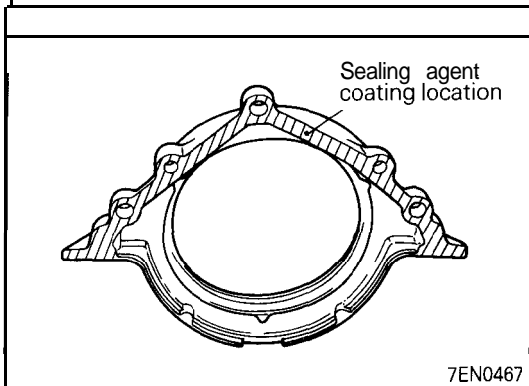
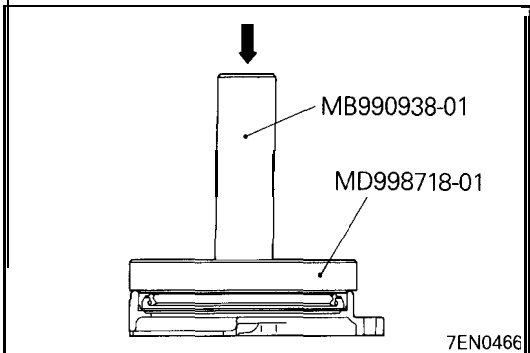

◆F◆ OIL SEAL CASE INSTALLATION

- (1) Apply specified sealant to the area shown in the illustration.

Specified sealant:

MITSUBISHI GENUINE Part No. MD970389 or equivalent

- (2) Apply a small amount of engine oil to the entire circumference of the oil seal lip section, and place the oil seal on the cylinder block.

BRACKET

REMOVAL AND INSTALLATION – DIAMANTE and 3000GT

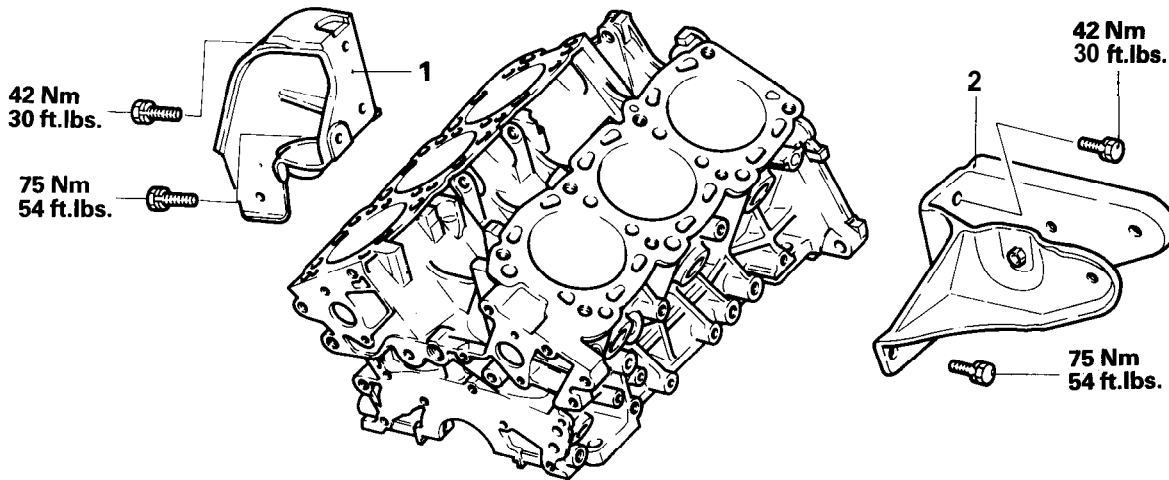

Removal steps

1. Engine support bracket, right
2. Engine support bracket, left

7EN0521

REMOVAL AND INSTALLATION – MONTERO and TRUCK

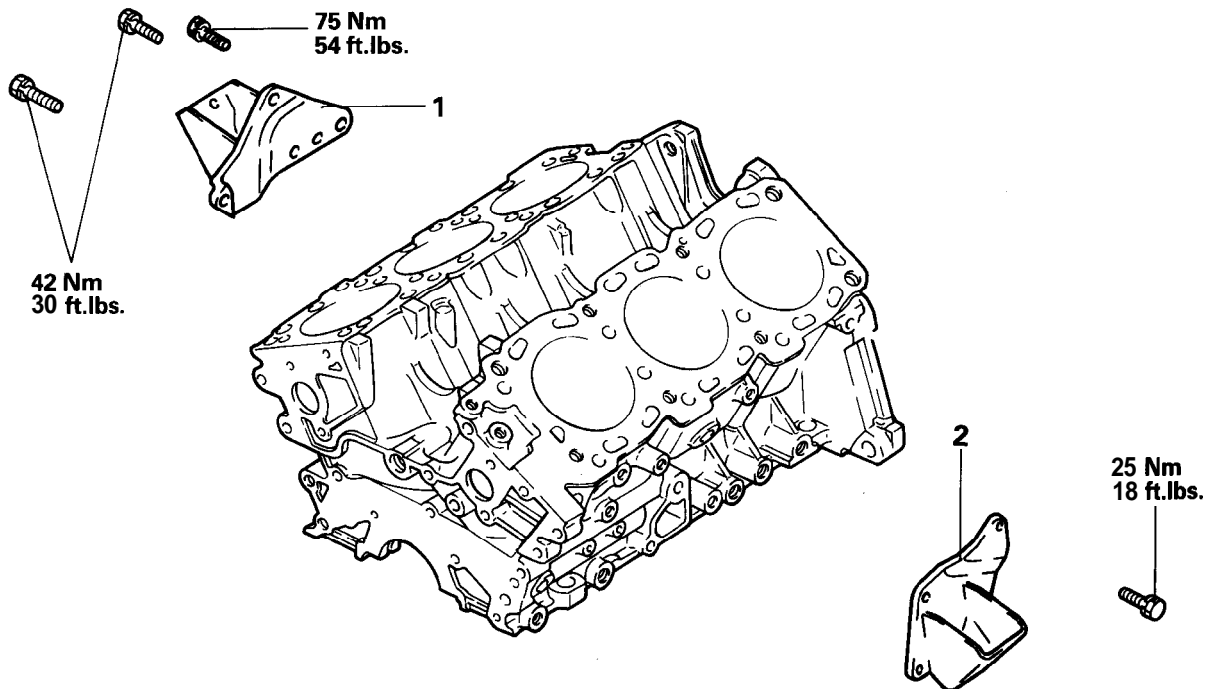

Removal steps

1. Roll stopper bracket, front
2. Roll stopper bracket, rear

7EN0133